



*Laser printer*

**FS-1050**



# **SERVICE MANUAL**

Published in Dec. '01

## Revision history

Version	Date	Replaced pages	Remarks
1.0	5-Dec-2001		



---

# Safety precautions

---

This booklet provides safety warnings and precautions for our service personnel to ensure the safety of their customers, their machines as well as themselves during maintenance activities. Service personnel are advised to read this booklet carefully to familiarize themselves with the warnings and precautions described here before engaging in maintenance activities.

## Safety warnings and precautions

Various symbols are used to protect our service personnel and customers from physical danger and to prevent damage to their property. These symbols are described below:

 **DANGER:** High risk of serious bodily injury or death may result from insufficient attention to or incorrect compliance with warning messages using this symbol.

 **WARNING:** Serious bodily injury or death may result from insufficient attention to or incorrect compliance with warning messages using this symbol.

 **CAUTION:** Bodily injury or damage to property may result from insufficient attention to or incorrect compliance with warning messages using this symbol.

### Symbols

The triangle () symbol indicates a warning including danger and caution. The specific point of attention is shown inside the symbol.

 General warning.

 Warning of risk of electric shock.

 Warning of high temperature.

 indicates a prohibited action. The specific prohibition is shown inside the symbol.

 General prohibited action.

 Disassembly prohibited.

 indicates that action is required. The specific action required is shown inside the symbol.

 General action required.

 Remove the power plug from the wall outlet.

 Always ground the printer.

# 1. Installation Precautions

## WARNING

• Do not use a power supply with a voltage other than that specified. Avoid multiple connections to one outlet: they may cause fire or electric shock. When using an extension cable, always check that it is adequate for the rated current. ....



• Connect the ground wire to a suitable grounding point. Not grounding the printer may cause fire or electric shock. Connecting the earth wire to an object not approved for the purpose may cause explosion or electric shock. Never connect the ground cable to any of the following: gas pipes, lightning rods, ground cables for telephone lines and water pipes or faucets not approved by the proper authorities. ....



## CAUTION:

• Do not place the printer on an infirm or angled surface: the printer may tip over, causing injury. ....



• Do not install the printer in a humid or dusty place. This may cause fire or electric shock. ....



• Do not install the printer near a radiator, heater, other heat source or near flammable material. This may cause fire. ....



• Allow sufficient space around the printer to allow the ventilation grills to keep the machine as cool as possible. Insufficient ventilation may cause heat buildup and poor copying performance. ....



• Always handle the machine by the correct locations when moving it. ....



• Always use anti-toppling and locking devices on printers so equipped. Failure to do this may cause the printer to move unexpectedly or topple, leading to injury. ....



• Avoid inhaling toner or developer excessively. Protect the eyes. If toner or developer is accidentally ingested, drink a lot of water to dilute it in the stomach and obtain medical attention immediately. If it gets into the eyes, rinse immediately with copious amounts of water and obtain medical attention. ....













• Advise customers that they must always follow the safety warnings and precautions in the printer's instruction handbook. ....







## 2. Precautions for Maintenance

### WARNING

- Always remove the power plug from the wall outlet before starting machine disassembly. .... 
- Always follow the procedures for maintenance described in the service manual and other related brochures. .... 
- Under no circumstances attempt to bypass or disable safety features including safety mechanisms and protective circuits. .... 
- Always use parts having the correct specifications. .... 
- Always use the thermostat or thermal fuse specified in the service manual or other related brochure when replacing them. Using a piece of wire, for example, could lead to fire or other serious accident. .... 
- When the service manual or other serious brochure specifies a distance or gap for installation of a part, always use the correct scale and measure carefully. .... 
- Always check that the printer is correctly connected to an outlet with a ground connection. .... 
- Check that the power cable covering is free of damage. Check that the power plug is dust-free. If it is dirty, clean it to remove the risk of fire or electric shock. .... 
- Never attempt to disassemble the optical unit in machines using lasers. Leaking laser light may damage eyesight. .... 
- Handle the charger sections with care. They are charged to high potentials and may cause electric shock if handled improperly. .... 

### CAUTION

- Wear safe clothing. If wearing loose clothing or accessories such as ties, make sure they are safely secured so they will not be caught in rotating sections. .... 
- Use utmost caution when working on a powered machine. Keep away from chains and belts. .... 
- Handle the fixing section with care to avoid burns as it can be extremely hot. .... 
- Check that the fixing unit thermistor, heat and press rollers are clean. Dirt on them can cause abnormally high temperatures. .... 
- Do not remove the ozone filter, if any, from the printer except for routine replacement. .... 

• Do not pull on the AC power cord or connector wires on high-voltage components when removing them; always hold the plug itself. ....



• Do not route the power cable where it may be stood on or trapped. If necessary, protect it with a cable cover or other appropriate item. ....



• Treat the ends of the wire carefully when installing a new charger wire to avoid electric leaks. ....



• Remove toner completely from electronic components. ....



• Run wire harnesses carefully so that wires will not be trapped or damaged. ....



• After maintenance, always check that all the parts, screws, connectors and wires that were removed, have been refitted correctly. Special attention should be paid to any forgotten connector, trapped wire and missing screws. ....



• Check that all the caution labels that should be present on the machine according to the instruction handbook are clean and not peeling. Replace with new ones if necessary. ....



• Handle greases and solvents with care by following the instructions below: .....  
· Use only a small amount of solvent at a time, being careful not to spill. Wipe spills off completely.  
· Ventilate the room well while using grease or solvents.  
· Allow applied solvents to evaporate completely before refitting the covers or turning the main switch on.  
· Always wash hands afterwards.



• Never dispose of toner or toner bottles in fire. Toner may cause sparks when exposed directly to fire in a furnace, etc. ....



• Should smoke be seen coming from the printer, remove the power plug from the wall outlet immediately. ....



### 3. Miscellaneous

#### WARNING

• Never attempt to heat the drum or expose it to any organic solvents such as alcohol, other than the specified refiner; it may generate toxic gas. ....



# Contents

## Chapter 1

1-1 Printer specifications .....	1-3
1-2 Names of parts .....	1-6
1-3 Safety information .....	1-7
1-4 Environmental requirements .....	1-10
1-5 About the toner container .....	1-14

## Chapter 2

2-1 Unpacking .....	2-3
2-2 Installing the printer .....	2-4
2-3 Using the operator panel .....	2-15

## Chapter 3

3-1 Maintenance/Adjustments .....	3-3
-----------------------------------	-----

## Chapter 4

4-1 Electrophotographic system .....	4-3
4-2 Paper feeding system .....	4-15
4-3 Electrical control system .....	4-18

## Chapter 5

5-1 General instructions .....	5-3
5-2 Disassembly .....	5-4

## Chapter 6

6-1 Troubleshooting .....	6-3
---------------------------	-----

## Appendix A

Timing charts .....	A-3
Wiring diagram .....	A-9

## Appendix B

Status page .....	B-3
-------------------	-----

## Appendix C

Parallel interface .....	C-3
USB interface .....	C-6
Serial interface (Optional) .....	C-7



# **Chapter 1**      **Product Information**

# Chapter 1 Contents

<b>1-1 Printer specifications</b> .....	<b>1-3</b>
1-1-1 Specifications .....	1-3
(1) Engine .....	1-3
(2) Controller .....	1-4
(3) Weight and dimensions .....	1-4
(4) Power requirements .....	1-5
(5) Environmental requirements .....	1-5
<b>1-2 Names of parts</b> .....	<b>1-6</b>
1-2-1 Name of parts .....	1-6
<b>1-3 Safety information</b> .....	<b>1-7</b>
1-3-1 Safety information .....	1-7
(1) Laser safety .....	1-7
(2) Laser notice .....	1-7
(3) Laser caution label on the scanner unit .....	1-7
(4) CDRH regulations (U.S.A.) .....	1-9
(5) Ozone concentration .....	1-9
(6) Optional equipment .....	1-9
(7) Important note on the interface connectors .....	1-9
<b>1-4 Environmental requirements</b> .....	<b>1-10</b>
1-4-1 Environmental conditions .....	1-10
(1) Clearance .....	1-11
(2) Places to avoid .....	1-12
(3) Note on power .....	1-12
(4) Removing the printer .....	1-13
<b>1-5 About the toner container</b> .....	<b>1-14</b>
1-5-1 Toner container .....	1-14
(1) Toner container handling .....	1-14
(2) Toner container storage .....	1-15

# 1-1 Printer specifications

## 1-1-1 Specifications

### (1) Engine

Item	Specification
Print method	Electrophotography laser scan
Print speed (when printing multiple pages)	14 pages/min. (A4) 15 pages/min. (Letter)
Resolution (dpi)	Fast 1200 mode (1800 horizontal/600 vertical) 600 horizontal/600 vertical
Smoothing	KIR (Kyocera Image Refinement)
First print (A4 or letter, 23 °C), depends on input data	22 seconds or less
Warm-up time at 23 °C	10 seconds or less (from sleep mode)
Maximum duty cycle (A4)	15 seconds or less (from power on)
Process unit life expectancy	100,000 pages of printing or 3 years, whichever reached first
Developing	Mono component developer
Laser diode	Visible laser
Main charger	Scorotron positive charging
Transferring	Negative charger roller
Separation	Curvature separation
Drum cleaning	Blade
Drum discharging	Eraser lamp (LED array)
Fuser	Heat roller and press roller
Paper	Plain paper: Legal to A5
Capacity of paper feed trays (80 g/m <sup>2</sup> [0.11 mm thickness])	Cassette: 250 sheets, MP tray: 50 sheets
Capacity of output trays (80 g/m <sup>2</sup> [0.11 mm thickness])	Face-up: 30 sheets, Face-down: 150 sheets

## (2) Controller

Item	Specification
CPU	PowerPC405/200MHz
System ROM	4 MB Flash DIMM
Font ROM	2 MB (16 M bit × 1)
Optional font ROM (Dip socket)	1 MB (Optional KPDL2 Upgrade kit)
Main (Video) RAM	16 MB (Standard-equipped on main board)
Expanding RAM (DIMM slot × 1)	Maximum 144 MB (Including the standard 16 MB main RAM) (Accepts any of 16/32/64/128 MB DIMM)
Host interface	Parallel: High-speed, bidirectional (IEEE1284) USB: Revision 1.1 standards Serial (option) : RS-232C/RS-422A, Max. speed: 115.2 Kbps (Optional serial interface board) KUIO-LV (3.3 V)
Page description language	Prescribe 2e
Standard emulation modes	PCL6, Diablo 630, IBM proprinter X24E, Epson LQ850, Line printer, KPDL2

## (3) Weight and dimensions

Item	Specification
Main unit (excl. protrusions)	Width: 378 mm (14 <sup>7</sup> / <sub>8</sub> inches)
	Height: 244 mm (8 <sup>3</sup> / <sub>4</sub> inches)
	Depth: 375 mm (14 <sup>3</sup> / <sub>4</sub> inches)
	Weight: 9.8 Kg (20 <sup>15</sup> / <sub>16</sub> lb.)

#### (4) Power requirements

Item	Specification
Voltage/current requirement	220 to 240 V AC $\pm 10\%$ , 50/60 Hz $\pm 2\%$ /3.8 A
Watts	Normal operation: 265 W
	Maximum: 818 W
	Standby: 13 W
	Sleeping: 5 W

#### (5) Environmental requirements

Item	Specification
Operating temperature and humidity	10 to 32.5 °C (50 to 90.5 °F), 20 to 80 %RH
Maximum altitude	2,000 m (6,500 feet)
Noise emission (Excluding peaks, measured at 1 m from printer, as per ISO7779)	50 dB (A) maximum/28 dB (A) at standby/unmeasureably low at sleeping)

# 1-2 Names of parts

## 1-2-1 Name of parts

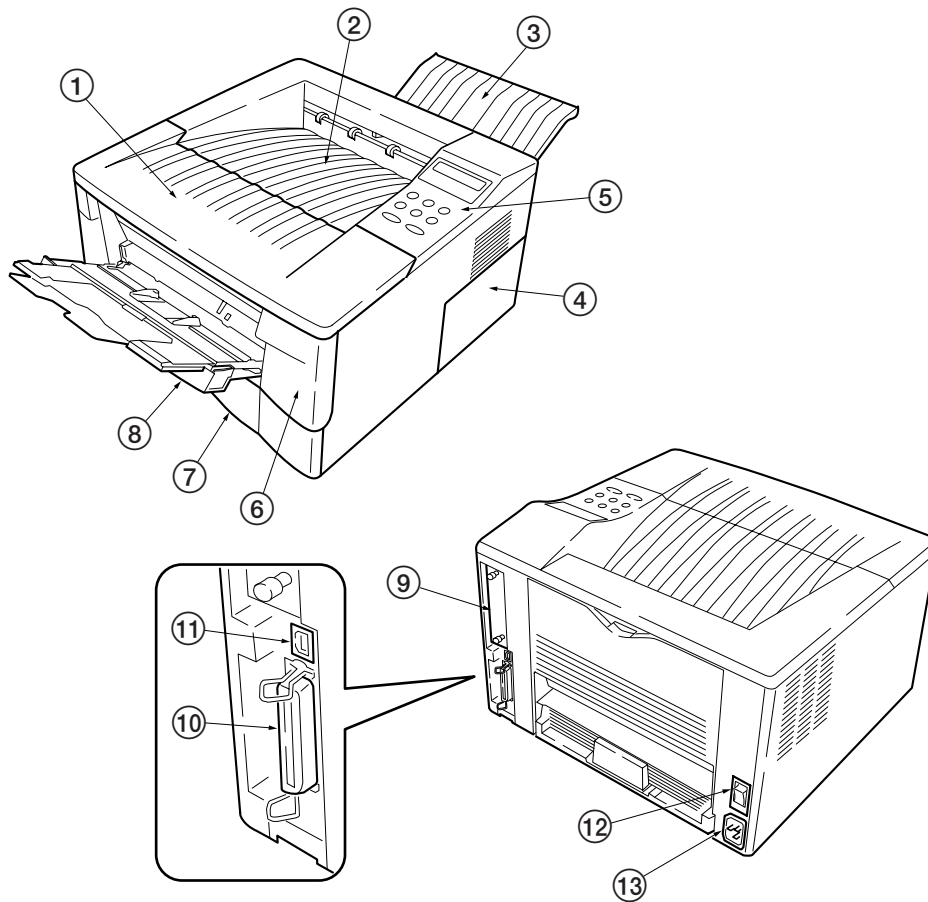

- ① Top cover
- ② Face-down output tray
- ③ Face-up output tray
- ④ Side cover
- ⑤ Operator panel
- ⑥ Front cover
- ⑦ Paper cassette
- ⑧ MP tray
- ⑨ Option card slot
- ⑩ Parallel interface connector
- ⑪ USB interface connector
- ⑫ Power switch
- ⑬ AC inlet

**Figure 1-2-1 Name of parts**

# 1-3 Safety information

## 1-3-1 Safety information

### (1) Laser safety

This printer is certified as a Class 1 laser product under the U.S. Department of Health and Human Services (DHHS) Radiation Performance Standard according to Radiation Control for Health and Safety Act of 1968. This means that the printer does not produce hazardous laser radiation. Since radiation emitted inside the printer is completely confined within protective housings and external covers, the laser beam cannot escape from the printer during any phase of user operation.

### (2) Laser notice

This printer is certified in the U.S. to conform to the requirements of DHHS 21 CFR Subchapter for Class I (1) laser products, and elsewhere is certified as a Class I laser product conforming to the requirements of IEC 825.

### (3) Laser caution label on the scanner unit

The laser scanner unit has the following label affixed atop. Observe these cautionary statements and figures when handling the laser scanner unit.

**WARNING**



Use of controls or adjustments or performance of procedures other than those specified herein may result in hazardous radiation exposure.

Label on the scanner unit  
(Inside the printer)

	<b>DANGER</b> - INVISIBLE LASER RADIATION WHEN OPEN. - AVOID DIRECT EXPOSURE TO BEAM.
	<b>ATTENTION</b> - RAYONNEMENT LASER INVISIBLE EN CAS D'OUVERTURE. - EXPOSITION DANGEREUSE AU FASCEAU.
	<b>VORSICHT</b> - UNSICHTBARE LASERSTRAHLUNG, WENN ABDECKUNG GEÖFFNET. - NICHT DIREKTIVAM AUSSETZEN.
	<b>ATTENZIONE</b> - RADIAZIONE LASER INVISIBLE IN CASO DI APERTURA. - EVITARE L'ESPOSIZIONE AL FASCIO.
	<b>PRECAUCION</b> - RADIAZIONE LASER INVISIBLE CUANDO SE ABRE. - EVITAR EXPOSERSE AL RAYO.
	<b>VAROJ</b> - AVATÄÄSSÄ OLET ALLTIMA NÄKYMÄTÖNÄLLÄ LASERBÄTELYLLÄ. - ÄLÄ KATSO SUITESIEN.
	<b>警告</b> - このカバーの内側では不可視レーザー光が放射されています。 - レーザー光にさらさないようにしてください。
	<b>警告</b> - 开盖时, 可能有激光外溢! 应避免激光直接照射。
	<b>警告</b> - 内部雷射放射中, 請勿隨意打開蓋子。
	<b>위험</b> - 레이저 광선을 직접 보지 마세요.

Label on the left cover rear side

**FS-1050**  
220-240V ~ 50/60Hz 3.8A  
**KYOCERA CORPORATION**  
CLASS 1 LASER PRODUCT TO IEC825  
LASER KLASSE 1 NACH IEC825  
KLASSE 1 LASER PRODUKT I.H.T. IEC825  
LUOKAN 1 LASERLAITE

**CAUTION**  
REMOVE POWER CORD BEFORE SERVICE AND FUSE REPLACEMENT.

**VORSICHT**  
VOR WARTUNG UND SICHERUNGSWECHSEL NETZSTECKER ZIEHEN.

**ATTENTION**  
POUR PREVENIR LES CHOC ELECTRIQUES, COUPER L'ALIMENTATION AVANT DE REMPLACER LE FUSIBLE.

**ATENCIÓN**  
DESENCHUFE EL CORDÓN DE ALIMENTACIÓN ANTES DEL SERVICIO Y DEL REEMPLAZO DEL FUSIBLE.

**PRECAUZIONE**  
PRIMA DI CAMBIARE I FUSIBILI O DI ESEGUIRE RIPARAZIONI, STACCAETE IL CADO DI ALIMENTAZIONE.

DESIGNED IN JAPAN / ASSEMBLED IN CHINA

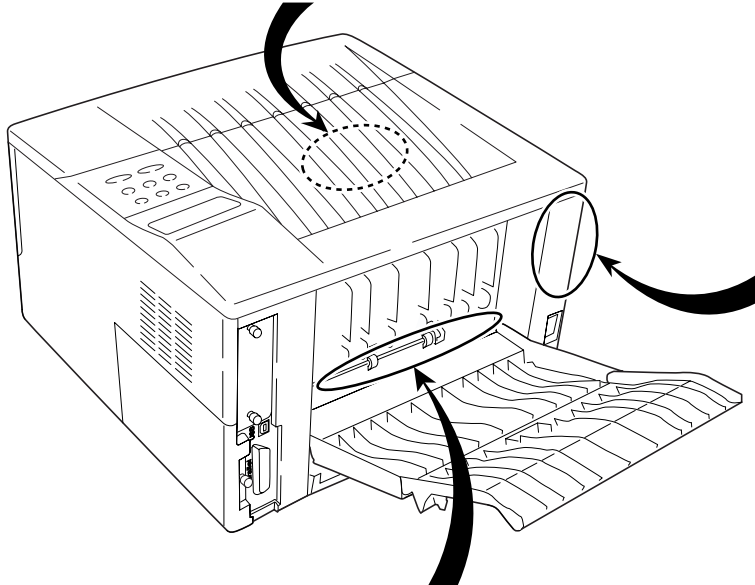

	<b>CAUTION</b> HOT SURFACE AVOID CONTACT	<b>ACHTUNG</b> HEISSE OBERFLÄCHE NICHT BERÜHREN	<b>ATTENTION</b> TEMPÉRATURE ÉLEVÉE NE PAS TOUCHER	<b>ATENCIÓN</b> EXTERIOR CALIENTE EVITE EL CONTACTO	<b>ATTENZIONE</b> SUPERFICIE CHE SCOTTA NON TOCCARE	<b>고온주의</b> 高温注意
--	--	---	--	---	---	---------------------

Label on the fuser unit

**Figure 1-3-1 Caution labels**



#### **(4) CDRH regulations (U.S.A.)**

The Center of Devices and Radiological Health (CDRH) of the U.S. Food and Drug Administration implemented regulations for laser products on August 2, 1976. These regulations apply to laser products manufactured after August 1, 1976. Compliance is mandatory for products marketed in the United States. A label indicating compliance with the CDRH regulations must be attached to laser products marketed in the United States.

#### **(5) Ozone concentration**

The printers generate ozone gas (O<sub>3</sub>) which may concentrate in the place of installation and cause an unpleasant smell. To minimize concentration of ozone gas to less than 0.1 ppm, we recommend you not to install the printer in a confined area where ventilation is blocked.

#### **(6) Optional equipment**

The printer may be optionally installed with the following units:

- PF-17 Paper feeder (250 sheets)
- Serial interface board
- Network interface card
- Memory card

#### **(7) Important note on the interface connectors**

Be sure to turn off printer power before connecting or disconnecting an interface cable to the printer. For protection against static discharge which may be applied to the printer's internal electronics through the interface connector(s), keep any interface connector which is not in use capped using the protective cap supplied.

# 1-4 Environmental requirements

## 1-4-1 Environmental conditions

The *Environmental requirements* section on page 1-5 should be observed to ensure the optimum operation of the printer. The use of the printer in a location which does not satisfy the requirements may result in troubles and risk shortening its service life.

The printer will work best if it is installed in a location that is:

- Level and well supported (Place the printer on a table or desk.)
- Not exposed to sunlight or other bright light (not next to an uncurtained window). Do not place the printer on an unstable cart, stand or table.
- Near an AC wall outlet, preferably one that can be used for the printer alone. The outlet should have a ground slot, or an adapter should be used. If you use an extension cord, the total length of the power cord plus extension cord should be 17 feet or 5 meters or less.
- Well ventilated, not too hot or cold, and not too damp or dry (See section *Environmental requirements* on page 1-5). If you install the printer where the temperature or humidity is outside the requirements in section Environmental requirements in chapter 1, the best print quality may not be expected and there will be an increased chance of paper jams.
- Provide a sufficient clearances around the printer to ensure ventilation and ease of access. (See section *Clearance* on next page).

## (1) Clearance

Allow the necessary minimum clearance on all sides of the printer as diagrammed below.

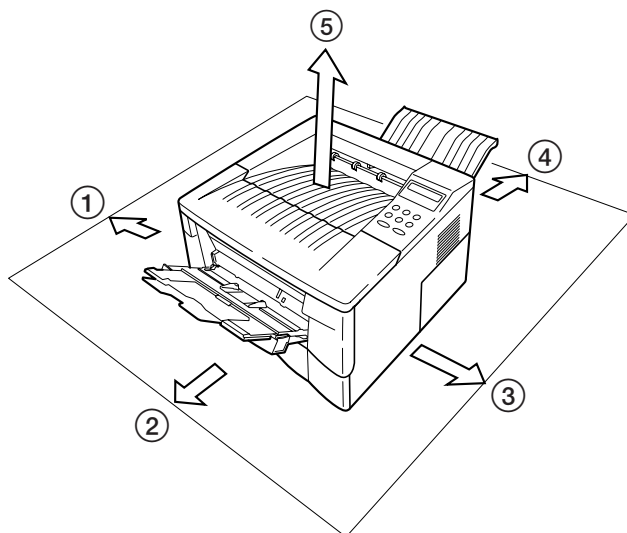

**Figure 1-4-2 Clearances**

Ref.	Clearance	Dimensions
①	Left	25 cm (9-7/8 inches)
②	Front	50 cm (19-11/16 inches)
③	Right	25 cm (9-7/8 inches)
④	Back	40 cm (15-3/4 inches)
⑤	Above	30 cm (11-13/16 inches)

## (2) Places to avoid

Avoid installing the printer in locations exposed to:

- Direct drafts of hot or cold air.
- Direct drafts of outside air. (Avoid locations next to outside doors.)
- Sudden temperature or humidity changes.
- Any source of high heat, such as a radiator or stove.
- Excessive dust. Dust and smoke may cause contamination on the laser scanner window, causing print quality problem.
- Vibration.
- Ammonia fumes or other harmful fumes. (In case of fumigating the room or saturate it with insecticide, remove the printer first.)
- Avoid greenhouse-like rooms. (Because of sunlight and humidity.)
- Avoid enclosed spaces that block ventilation.
- Avoid sites more than 6,500 feet or 2,000 meters above sea level.

## (3) Note on power

Use only the power source voltage conforming to the printer's rated power voltage. Do not use other power sources.

- Disconnect the printer from the power source before attempting removal or replacement of an electrical component or a printed-circuit board.
- The printer should not be connected to a power source until the instruction is given to do so when performing tests described in this manual.
- In connecting the printer power, exercise an extreme care in handling the power supply or any other electric parts which may give an electric shock.
- Before performing maintenance or repair, power from both the power source and the associated peripheral devices (computer, sorter, etc.) should be disconnected, unless otherwise specified.
- To avoid possible electrical shock, extreme caution must be exercised in handling the power cord and any other electrical part.
- An easily accessible socket outlet must be provided near the equipment.

### **WARNING**



As the disconnect device is not incorporated in the printer's AC primary circuit, an easily accessible socket outlet must be provided near the equipment.

#### **(4) Removing the printer**

Observe the following precautions in removal and transportation of the printer.

- Be sure to repack the printer in its original carton.
- Do not leave the printer, toner container, process unit and other printer modules inside a vehicle if the outdoor temperature is more than 25 °C. As unexpectedly high temperature may develop inside when a vehicle is parked for a long period of time, the drum, toner container, process unit and the supplies should be removed from the vehicle. The vehicle during transportation should be parked in the shade or with the window open to allow minimum air circulation or the adequate air conditioning should be made.
- Should the printer be left in a vehicle, it may not be exposed to the temperature change of more than 7 °C within 30 minutes.
- Before removing the printer to a warm place, wrap it in a blanket, etc., before crating it. Allow approximately two to three hours after having moved after uncrated. Failure to observe the above may result in moisture condensation which will affect the performance of the printer.

# 1-5 About the toner container

## 1-5-1 Toner container

The printer should use a TK-17 toner kit. To ensure the high print quality and long service life, the following handling precautions should apply.

### CAUTION



As the Ecosys printers are designed to ensure the optimum print quality when used with Kyocera's proprietary toner, Kyocera do not recommend to use any refilled toner containers that may be available commercially. This is because Kyocera have no means of control over how such refilled toner could affect the print quality and the reliability of the printer.

### (1) Toner container handling

To loosen and mix the toner inside before use, with the label side down, thoroughly shake the toner container ① horizontally at least five times.

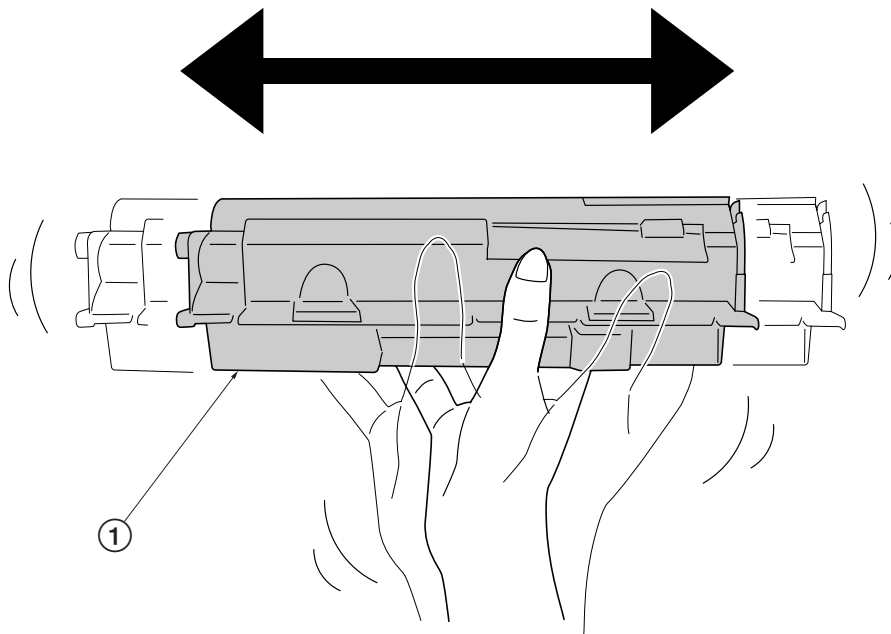

Figure 1-5-1 Toner container handling

### CAUTION



Do not attempt to disassemble or refill the toner container.

## (2) Toner container storage

The toner contained in the container is susceptible to temperature and humidity. To ensure the high print quality, store the toner container in a place that satisfies the following environmental conditions:

Temperature: -20 to 40 °C (-4 to 104 °F)

Humidity: 15 to 90 % RH

### NOTE

If the toner container is removed from the printer's developer unit, put it in a protective bag and keep it in a dark place.

### CAUTION



If the printer is shipped for return, etc., do not ship it with the toner container installed. Otherwise, toner may leak and contamination may result in the printer.

## **Chapter 2**      **Installation/Operation**



## Chapter 2 Contents

<b>2-1 Unpacking</b> .....	<b>2-3</b>
2-1-1 Unpacking and inspection .....	2-3
<b>2-2 Installing the printer</b> .....	<b>2-4</b>
2-2-1 Installing the toner container .....	2-4
2-2-2 Expanding memory .....	2-8
(1) Minimum memory requirements .....	2-8
(2) DIMM specifications .....	2-8
(3) Notes on handling DIMM .....	2-9
(4) Installing the DIMM .....	2-10
(5) Testing the expansion memory .....	2-11
(5) Installing the memory card (CompactFlash) .....	2-12
(6) Installing the network interface card .....	2-14
<b>2-3 Using the operator panel</b> .....	<b>2-15</b>
2-3-1 Operator panel .....	2-15
(1) LED Indicators .....	2-15
(2) keys .....	2-16
(3) LCD message display .....	2-17
Interface indicator .....	2-18
Paper size indicator .....	2-18
2-3-2 Menu selection system .....	2-19
(1) Menu selection and sequence .....	2-19

## 2-1 Unpacking

### 2-1-1 Unpacking and inspection

The package should contain the printer and the accessories as shown in the figure below. Remove the printer and all the accessories from the package. For unpacking, place the box containing the printer on a flat, stable surface. Remove the manuals, toner kit, and other items located on top of the spacer and remove the spacer. Carefully remove the printer.

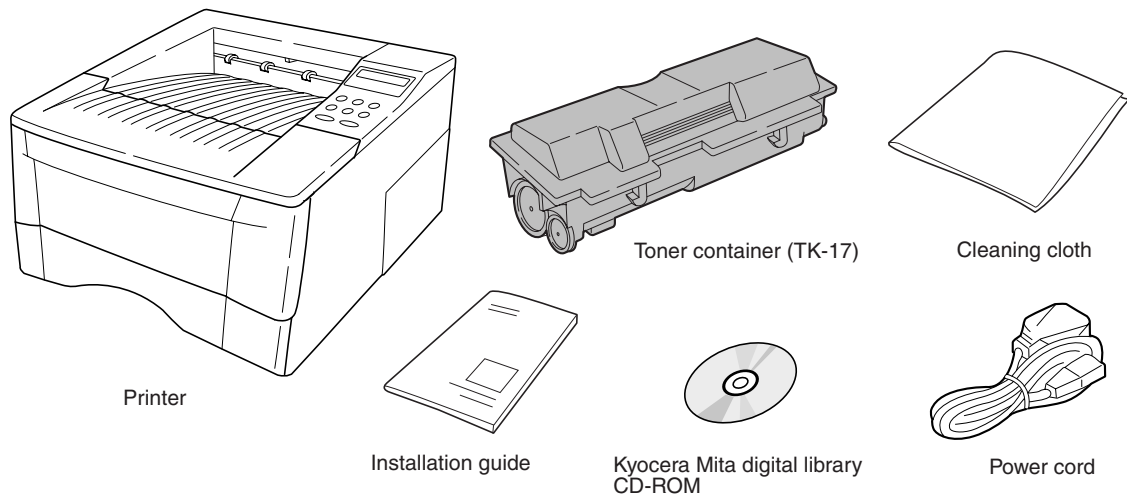

**Figure 2-1-1 Unpacking (1)**

Remove the tape on the rear side of the printer, and remove the two spacers and the printed notice from the paper cassette.

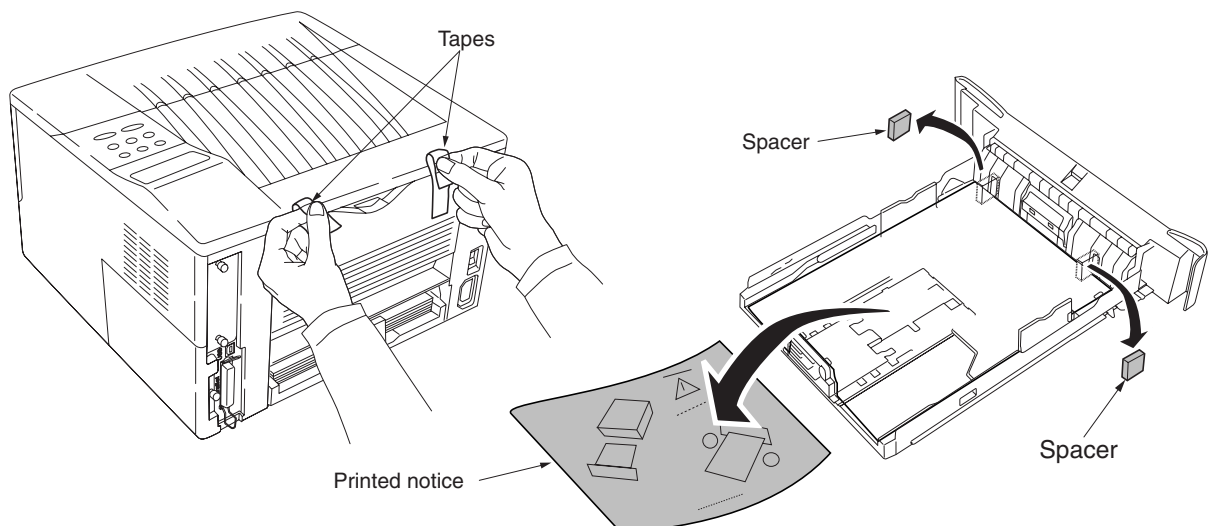

**Figure 2-1-2 Unpacking (2)**

## 2-2 Installing the printer

Installing the printer requires several steps. Proceed as follows in sequence. If the option paper feeder is used with the printer, begin installation with connecting the printer and the paper feeder. For details, refer to the *optional Paper feeder's Service Manual*.

### 2-2-1 Installing the toner container

1. Open the top cover all the way.
2. Confirm that the lock lever #1 ① is in the release (forward) position. If not, pull it forward until it is in the release position.

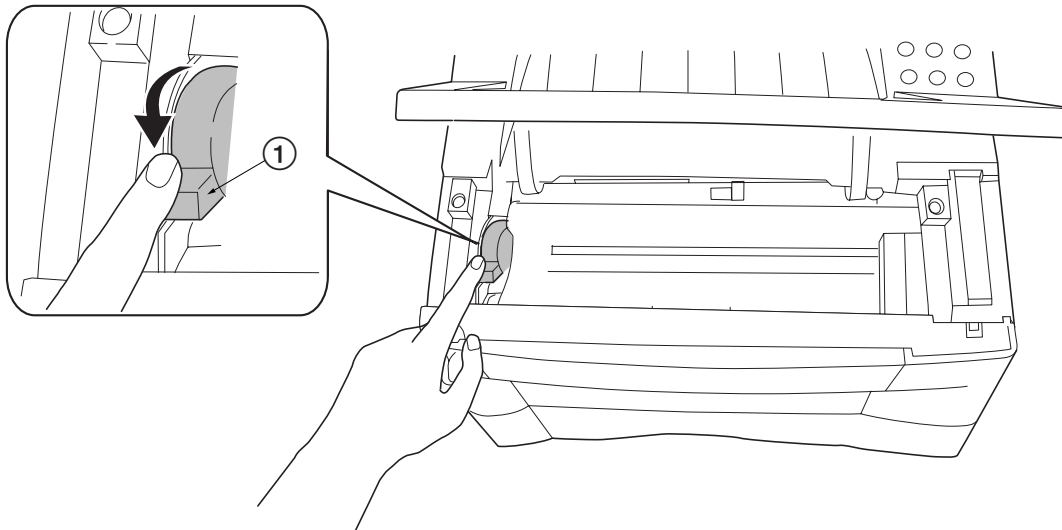

**Figure 2-2-1 Confirming the lock lever #1**

3. Take the toner container ② from the bag. Hold it with the protective seal ③ (orange-colored) facing up. Shake the toner container ② horizontally at least five times. This ensures that the toner is evenly distributed inside.

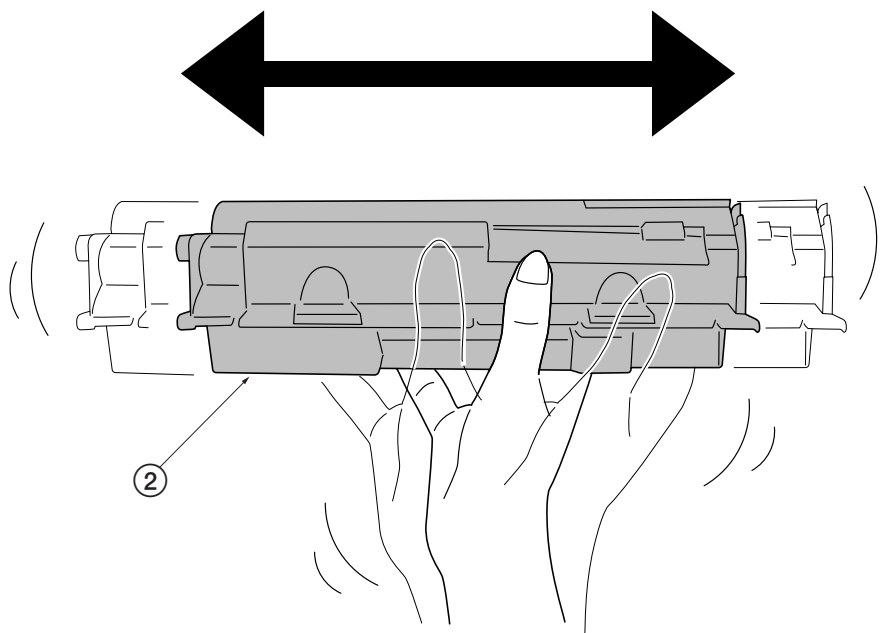

**Figure 2-2-2 Shaking the toner container**

4. Carefully remove the protective seal ③.

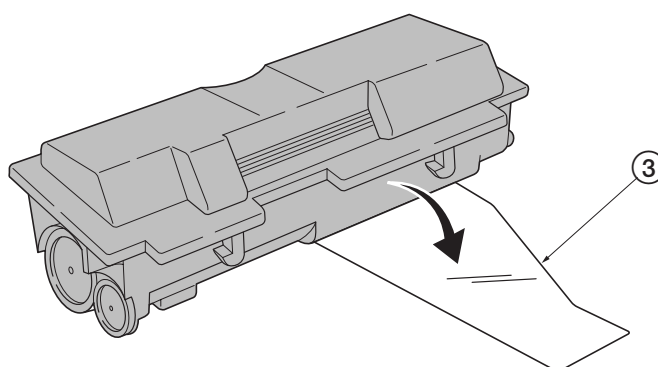

**Figure 2-2-3 Removing the protective seal**

5. Install the toner container ② into the printer.
6. Push firmly on the top of the toner container ② at the positions marked [PUSH HERE].

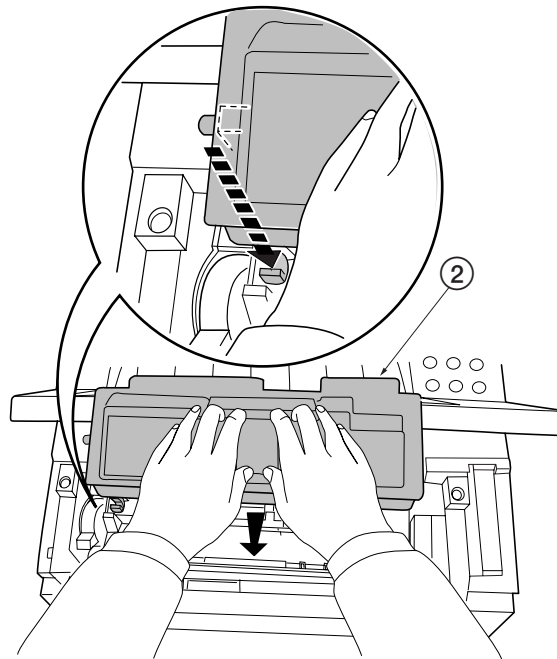

**Figure 2-2-4 Installing the toner container**

7. Push the lock lever #1 ① to the lock position.
8. Close the top cover ④.

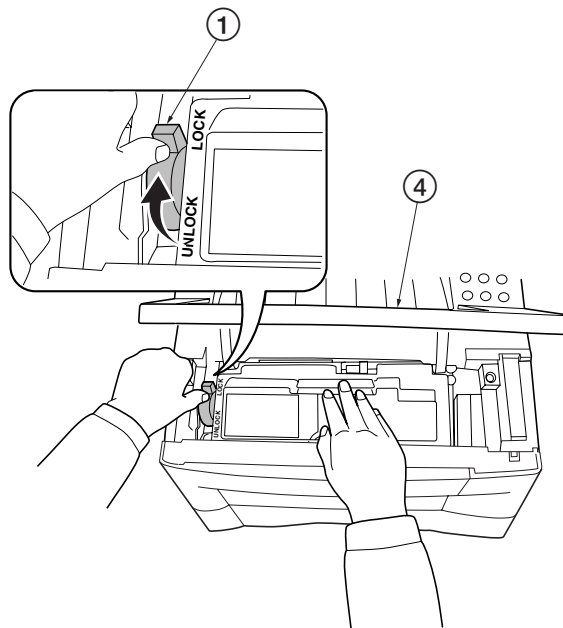

**Figure- 2-2-5 Locking the toner container**

**NOTE**

The printer is shipped from the factory with no toner supplied in its developer (Process unit). When the printer is first switched on after the toner container is installed in the manner above, there will be a delay of several minutes before the printer gets ready to print a job.

This delay is necessary for the printer to fill the developer reservoir with a sufficient amount of toner to continuously support a print job. The period of time is approximately 15 minutes.

If the toner low or replace toner indication does not go off after installing the new toner container, take the toner container out once, shake it well, then install again.

## 2-2-2 Expanding memory

The FS-1050 printer comes standard equipped with 16 MB of main memory on the main board. Printer memory can be expanded to up to the maximum 144 MB (16 + 128 MB).

### (1) Minimum memory requirements

Refer to the table below for minimum memory requirements in various environments.

Printing environment (Emulation)	Resolution	
	300 dpi	600 dpi
HP LaserJet 5P (factory setting)	2 MB	2 MB
HP LaserJet 5P with resource protection	-	10 MB

### (2) DIMM specifications

Memory size in MB	16, 32, 64, 128 MB
Number of pins	100 pins
Access speed	66 MHz
Parity	None
Bus width	32 bits

### (3) Notes on handling DIMM

Before proceeding to install DIMM, read the following notes for handling the main board and DIMMs:

- Protect the electronics by taking these precautions:
- Before touching a DIMM, touch a water pipe or other large metal object to discharge yourself of static electricity. While doing the work, it is recommended that you wear an antistatic wrist strap.
- Touch the main board and DIMM only by the edges, not in the middle.

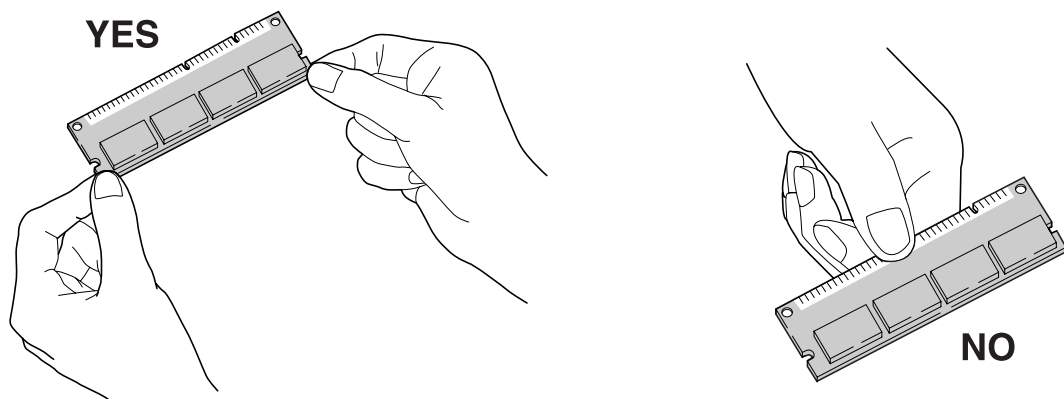

Figure 2-2-6 Handling DIMM



#### (4) Installing the DIMM

The main board of the printer is equipped with one socket for memory expansion. Expansion memory is available in the form of DIMM (Dual In-line Memory Module).

#### CAUTION



Take precautions that no foreign substances such as metal chips or liquid get inside the printer during the installation process. Operation of the printer during the presence of a foreign substance may lead to fire or electric shock.

#### WARNING



Turn the printer's power switch off. Unplug the printer's power cable and disconnect the printer from the computer or the network.

Remove the side cover ① as shown in the figure below.

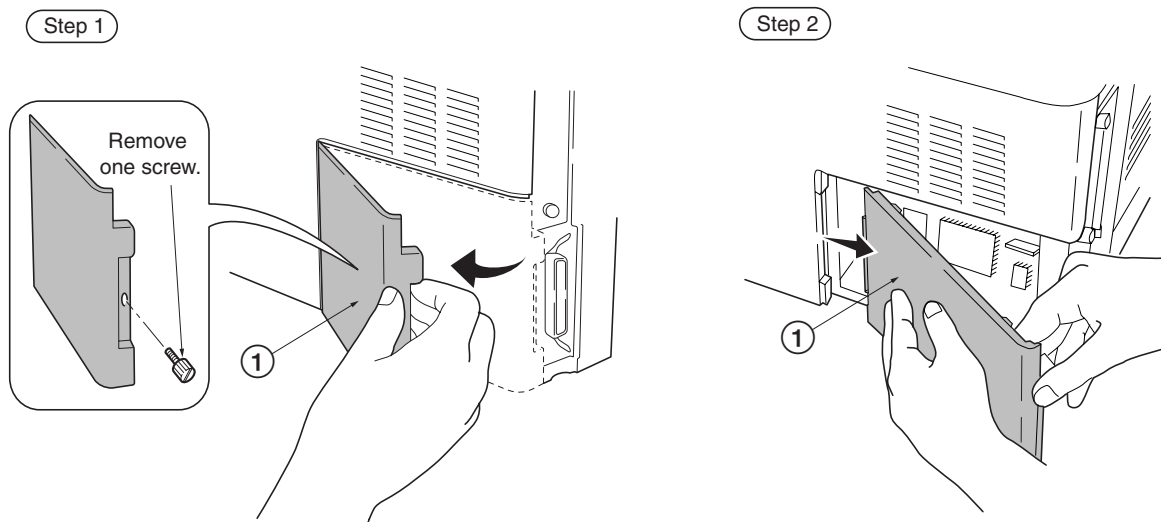
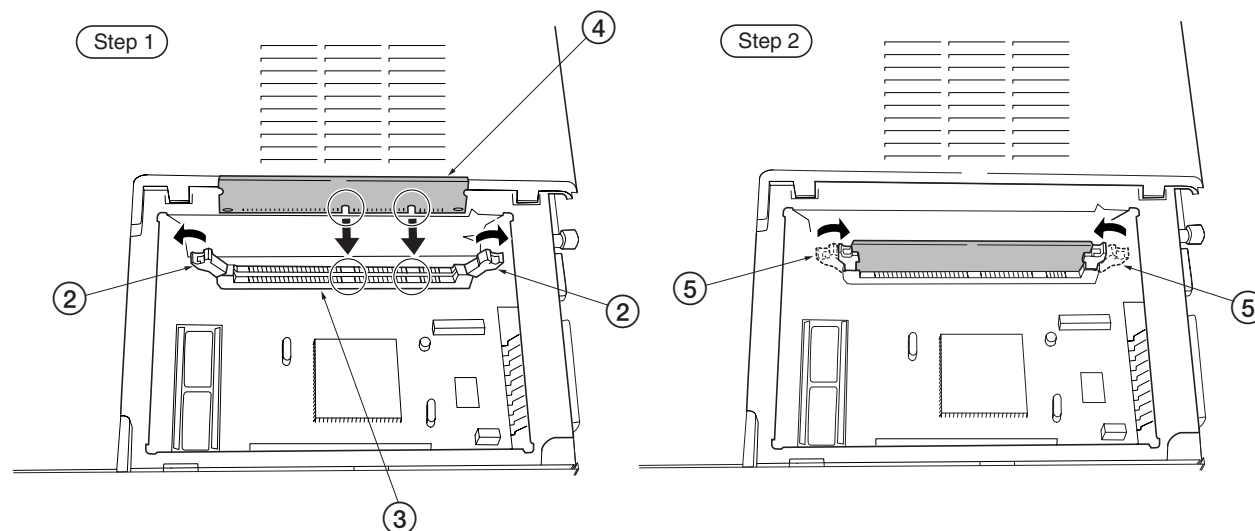

Figure 2-2-7 Removing side cover

Open the clips ② on both ends of the DIMM socket ③. Insert the DIMM ④ into the DIMM socket ③ so that the notches on the DIMM align with the corresponding protrusions in the slot. Close the clips ⑤ on the DIMM slot to secure the DIMM.



**Figure 2-2-8 Inserting the DIMM**

### **(5) Testing the expansion memory**

After installing DIMM in the printer, test the printer to see if the installation has been successful. To test the expansion memory, turn printer power on and print a status page. If the installation has been successful, the Available Memory item of the status page will show the expanded memory size corresponding to the amount of memory added.

## (5) Installing the memory card (CompactFlash)

The main board of the printer is equipped with one slot for memory card.

### CAUTION



Take precautions that no foreign substances such as metal chips or liquid get inside the printer during the installation process. Operation of the printer during the presence of a foreign substance may lead to fire or electric shock.

### WARNING



Turn the printer's power switch off. Unplug the printer's power cable and disconnect the printer from the computer or the network. Never insert or remove a memory card while the printer power is ON.

Failure to turn the power switch OFF will immediately halt the printer with a **Memory card err20** message (this message may not always appear). It also could result in any damage to the printer's electronic parts or the memory card. Turn the power switch ON again to restart the printer.

Remove the two screws (1) from the option interface slot cover (2) and remove the slot cover (or network interface card (3) or the serial Interface board).

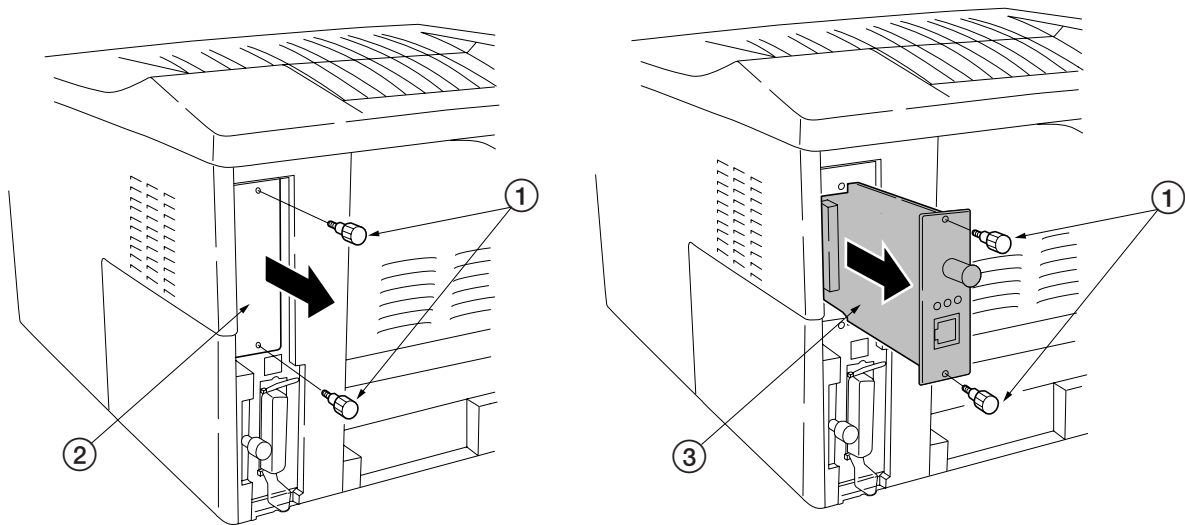

**Figure 2-2-9 Removing the option interface slot cover**

Insert the memory card ④ in the slot. Insert as shown in the figure. Push it in all the way. Close and secure the slot cover (or network interface card or the serial Interface board) .

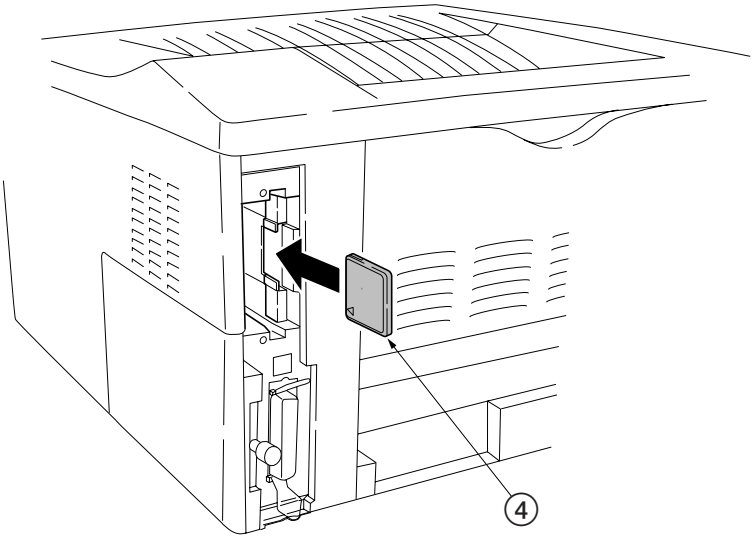

**Figure 2-2-10 installing the memory card**

## (6) Installing the network interface card

If the serial interface board kit is installed, remove it to use the network interface card.

### CAUTION



Take precautions that no foreign substances such as metal chips or liquid get inside the printer during the installation process. Operation of the printer during the presence of a foreign substance may lead to fire or electric shock.

### WARNING



Turn the printer's power switch off. Unplug the printer's power cable and disconnect the printer from the computer or the network. Never insert or remove a network interface card while the printer power is ON.

Remove the two screws ① from the option interface slot cover ② and remove the slot cover ( or the serial Interface board) .Insert the network interface card ③ in the slot. Insert as shown in the figure. Push it in all the way. Secure the network interface card by using two screws ①.

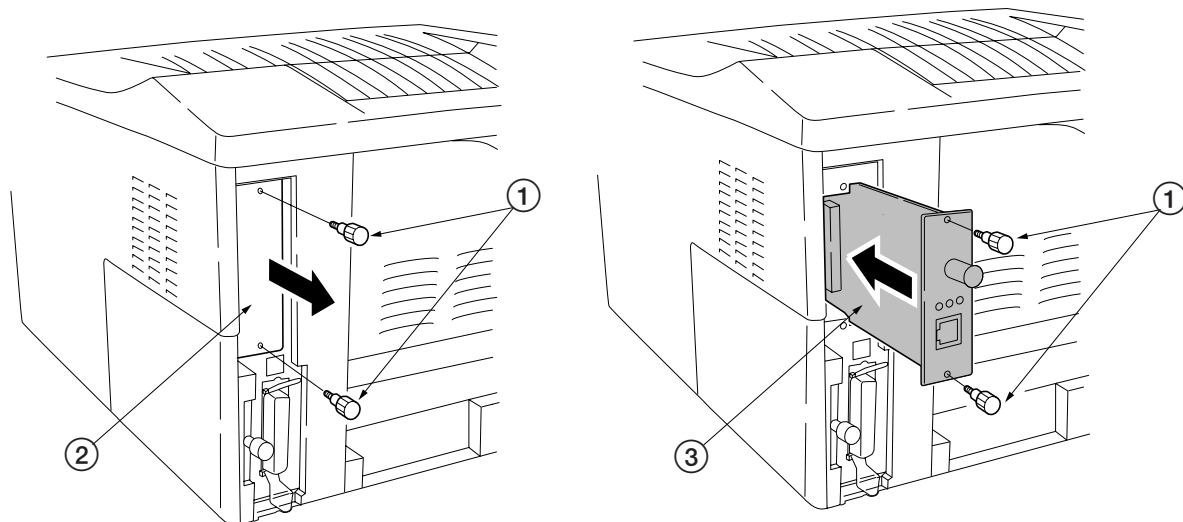

Figure 2-2-11 installing the memory card

## 2-3 Using the operator panel

This section provides explanation on how to use the printer's operator panel for basic operation. For details, refer to the printer's *User's Manual*.

### 2-3-1 Operator panel

The printer's operator panel has the following LED indicators, keys, and LCD message display. Note that adjustments to the printer parameters made using these keys may be overridden by those made from within the application software.

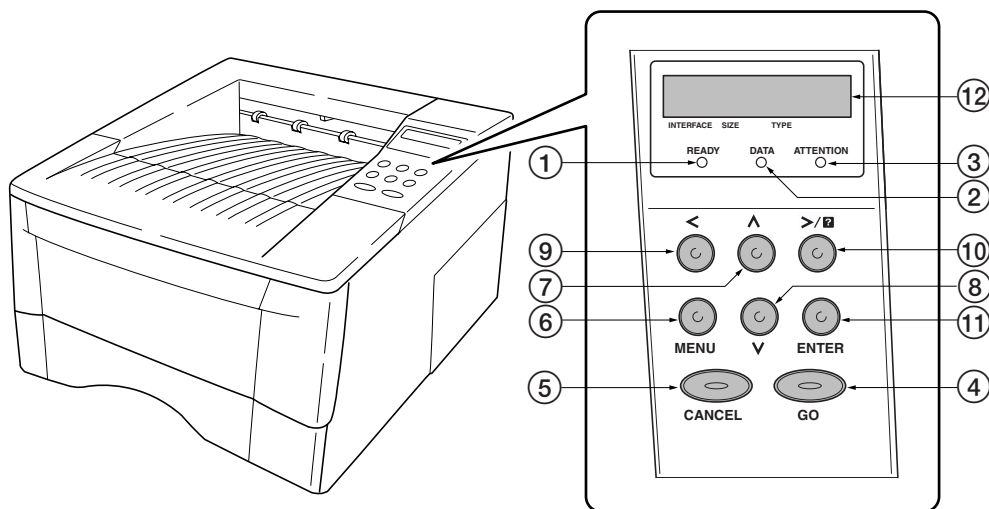

**Figure 2-3-1 Operator panel**

#### (1) LED Indicators

Indicator	Condition	Descriptio
① READY indicator	Flashing	Indicates errors that you can correct himself or herself.
	Lit	Indicates that the printer is online and ready.
	Off	Indicates that the printer is offline. The printer can receive data, but will not print it. The indicator can also signal that printing has been manually or automatically stopped due to an error.
② DATA indicator	Flashing	Indicates a data transfer in process.
	Lit	Indicates either that data is being processed, or that data is being written to the memory card.
	Off	Indicates that the printer is idle.

Indicator	Condition	Description
③ ATTENTION indicator	Flashing	Indicates that paper has run out, that memory is insufficient, that toner is low, or other warning messages.
	Lit	Indicates common errors (such as controller errors), when mechanical maintenance is needed or indicates a problem that requires a call to the service center.
	Off	Indicates the printer is operating normally.

## (2) keys

Key	Function
④ GO key	<ul style="list-style-type: none"> <li>• Switches the printer online and offline (even offline, the printer can receive data).</li> <li>• Cancels specific errors.</li> </ul>
⑤ CANCEL key	<ul style="list-style-type: none"> <li>• Cancels a printing job.</li> </ul> <p>To cancel, proceed as follows:</p> <ol style="list-style-type: none"> <li>1. Make sure if Processing appears on the message display.</li> <li>2. Press the CANCEL key.</li> <li>3. Print Cancel? appears on the message display and then interface to be canceled. Parallel Serial (appears only when an optional serial interface is present) Option (appears only when an optional network interface card is installed) Press the CANCEL key again if you wish to stop the cancellation of printing.</li> <li>4. Select the interface to cancel using the or key and then press the ENTER key. Printing from the selected interface will stop. Cancelling data appears in the message display and printing stops after the current page is printed.</li> </ol>
⑥ MENU key	<ul style="list-style-type: none"> <li>• Resets numeric values or cancels a setting procedures.</li> <li>• When pressed during mode selection, it ends the setting and the printer returns to the Ready condition.</li> <li>• Used to select the emulation, font, character code set; to read a memory card; and more.</li> </ul>

Key	Function
⑦ ^ Key	Used to access desired items or input numeric values. In some control procedures, the < and > keys are used to access or exit submenu items.
⑧ v key	Used to access desired items or input numeric values. In some control procedures, the < and > keys are used to access or exit submenu items.
⑨ < key	Used as the < key in mode selection.
⑩ > key	Used as the > key in the mode selection function.
⑪ ENTER key	Confirms numeric values and other selections.

### (3) LCD message display

The LCD message display ⑫ gives information in the form of short messages. The eight messages listed below are displayed during normal warm-up and printing. Other messages appear when the printer needs the operator's attention as explained in Chapter 6 *Troubleshooting*.

Message	Meaning
Self test	The printer is self-testing after power-up.
Please wait	Please wait The printer is warming up and is not ready.
Ready	The printer is ready to print.
Processing	The printer is receiving data, generating graphics, reading a memory card or printing.
Sleeping	The printer is in Sleep mode. The printer wakes from Sleep mode whenever a key on the operator panel is pressed, the cover is opened or closed, or data is received. The printer then warms up and goes online. The time that the printer takes to enter Sleep mode depends on the Sleep Timer setting.
Cancelling data	Jobs inside the printer are being cancelled. To cancel a job, see the table on page 1-5.
Waiting	The printer is waiting for the end-of-job command before printing the last page. Pressing the GO key allows you to obtain the last page immediately.
FormFeed TimeOut	The printer is printing the last page after a waiting period.



## Interface indicator

The LCD message display also shows the interface that is currently used in the form of the following abbreviations:

Message	Meaning
PAR	Standard bidirectional parallel interface
USB	Standard USB interface
SER	Optional serial interface (RS-232C)
OPT	Optional network interface card
---	No interface is currently used.

Each interface has a time-out time of 30 seconds during which the other interface should wait to receive a print job. Even a print job has been complete on the interface, you should wait for this period until the other interface begins printing the job.

## Paper size indicator

The LCD message display also provides information about the paper size of the paper cassette. While the printer is Processing data to print, the paper size indicator switches to indicate the paper size selected by the application software. The following abbreviations are used to indicate paper sizes.

Message	Paper size
A4	ISO A4 (21 × 29.7 cm)
DL	ISO DL (11 × 22 cm) *
A5	ISO A5 (14.8 × 21 cm)
C5	ISO C5 (16.2 × 22.9 cm) *
A6	ISO A6 (10.5 × 14.8 cm) *
b5	ISO B5 (17.6 × 25 cm) *
B5	JIS B5 (18.2 × 25.6 cm)
EX	Executive (7-1/4 × 10-1/2 inches) *
B6	JIS B6 (12.8 × 18.2 cm) *
#6	Commercial 6-3/4 (3-5/8 × 6-1/2 inches) *
LT	Letter (8-1/2 × 11 inches)
#9	Commercial 9 (3-7/8 × 8-7/8 inches) *
LG	Legal (8-1/2 × 14 inches)
HA	Japanese postcard (10 × 14.8 cm) *
MO	Monarch (3-7/8 × 7-1/2 inches) *
OH	Return postcard (20 × 14.8 cm) *
BU	Business (4-1/8 inches) *
CU	Custom size (14.8 × 21 cm to 21.6 × 35.6 cm)

\* with only the MP tray feeding

## 2-3-2 Menu selection system

The MENU key on the operator panel allows you to use the menu selection system to set or change the printer environment such as the paper source, emulation, etc. Settings can be made when Ready is indicated on the printer message display. The printer obeys the most recently received printer settings sent from the application software, or from the printer driver, which take priority over operator panel settings.

### (1) Menu selection and sequence

The following is the hierarchy diagram of the menu selection system of the printer.

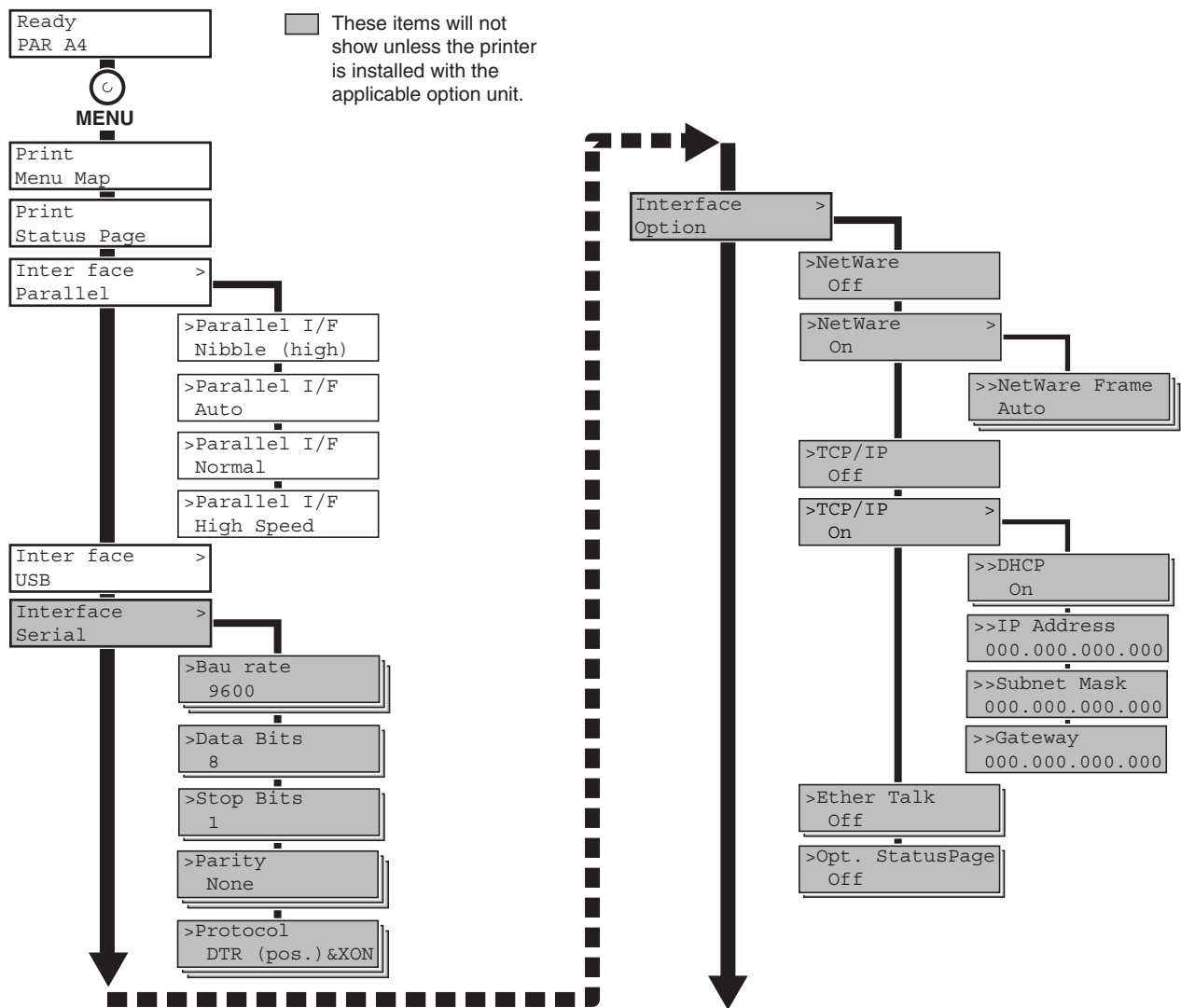

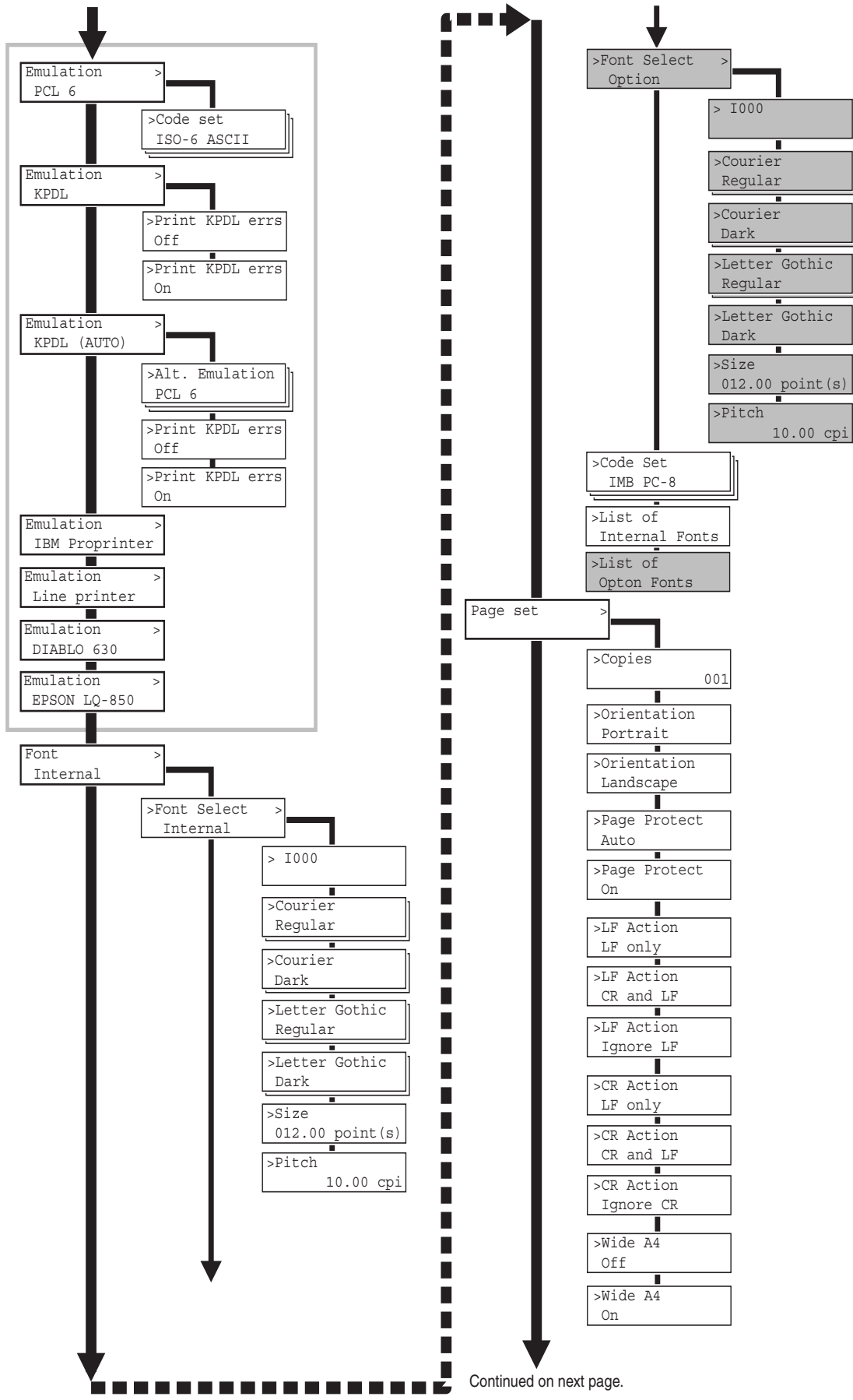

Continued on next page.

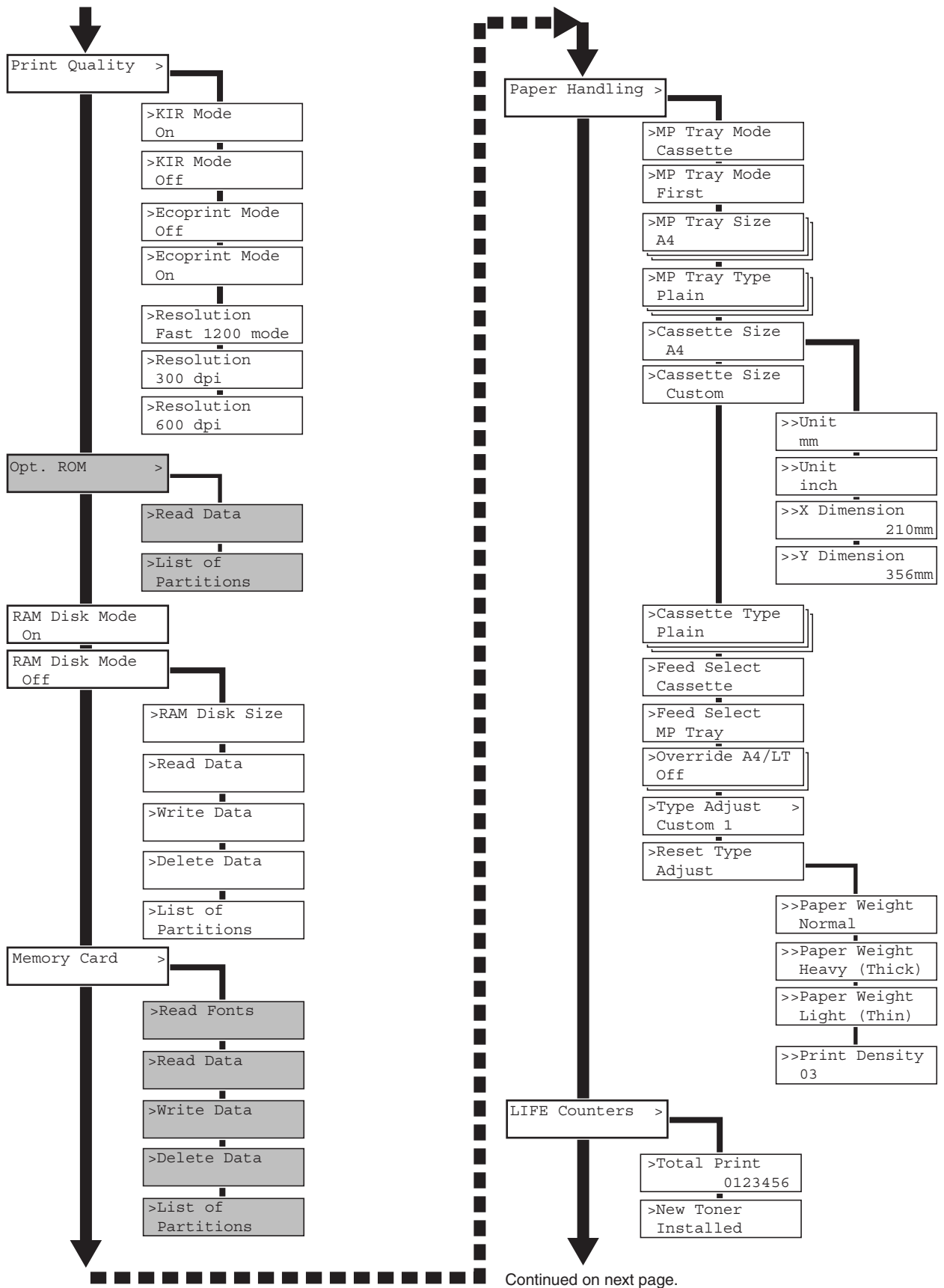

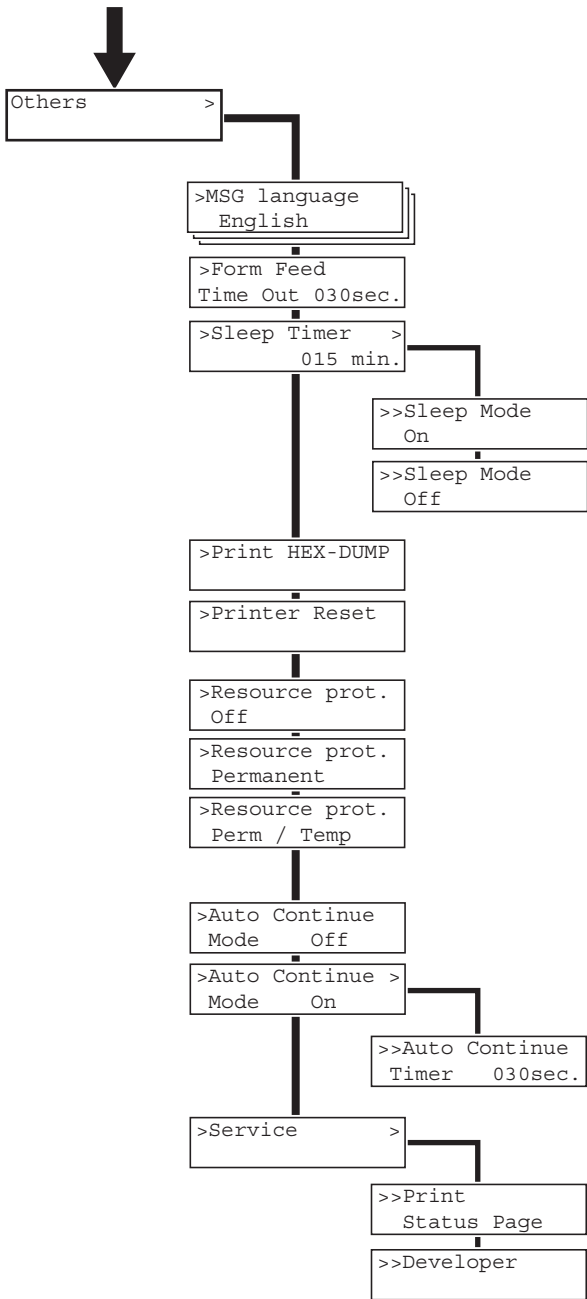

## **Chapter 3      Maintenance/Adjustments**

## Chapter 3 Contents

<b>3-1 Maintenance/Adjustments .....</b>	<b>3-3</b>
3-1-1 Life expectancy of modules .....	3-3
3-1-2 Toner container .....	3-4
(1) When to replace the toner container .....	3-4
(2) Notes on changing toner container .....	3-4
(3) Toner container replacement .....	3-5
(4) Toner saver mode (EcoPrint) .....	3-6
3-1-3 Cleaning the printer .....	3-7
(1) Cleaning the registration roller .....	3-8
(2) Cleaning the main charger wire .....	3-8
3-1-4 Updating the firmware .....	3-9
(1) Firmware program data format .....	3-9
(2) Downloading the firmware from the parallel interface .....	3-10
(3) Downloading the firmware from the memory card .....	3-12
(4) Downloading errors .....	3-14

## 3-1 Maintenance/Adjustments

### 3-1-1 Life expectancy of modules

The table below shows the nominal life expectancy for modules. Detailed part information for each module (except toner container) can be found in *Parts Catalog*.

**Table 3-1-1 Life expectancy of modules**

Kit	Module	Nominal life (pages)	Remarks
TK-17	Toner container	6,000	User-replaceable
PU-42	Process unit	100,000	User-replaceable



### 3-1-2 Toner container

Assuming an average toner coverage of 5 % with *EcoPrint* mode turned off, the toner container will need replacing approximately once every 6,000 printed pages.

**Table 3-1-2 Toner container**

Kit	Life in pages
TK-17	6,000

Based on letter or A4 size paper; average print density of 5 %.

**NOTE** In the case of a new printer in which a toner kit has been installed for the first time, the number of copies that can be printed will be approximately 3,000.

#### (1) When to replace the toner container

When the printer runs low on toner, the Toner indicator flashes on the operation panel. Be sure to promptly replace the toner container and clean the inside of the printer when this message appears. If the printer stops printing while the Toner indicator is lit, replace the toner container to continue printing.

#### (2) Notes on changing toner container

Observe the following cautions when replacing the toner container:

- Do not attempt to disassemble the old toner container and reuse the waste toner inside.
- Keep magnetic media such as floppy disks away from the toner container.
- Be sure to clean the parts as instructed in this section at the same timing of replacing toner container.
- Use of the toner kit TK-17 is highly recommended for the optimum operation of the printer.

### (3) Toner container replacement

To replace the toner container, open the top cover. Pull lock lever #1 ① to the release [UNLOCK] position, then pull lock lever #2 ② to the release (right) position.

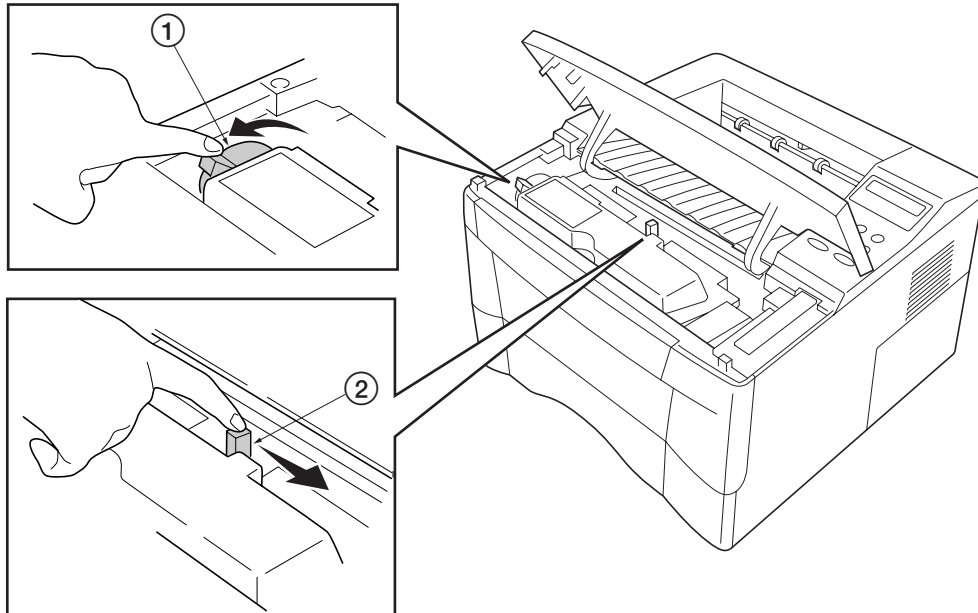

**Figure 3-1-1 Releasing Lock levers #1 and #2**

Gently remove the old toner container ③.

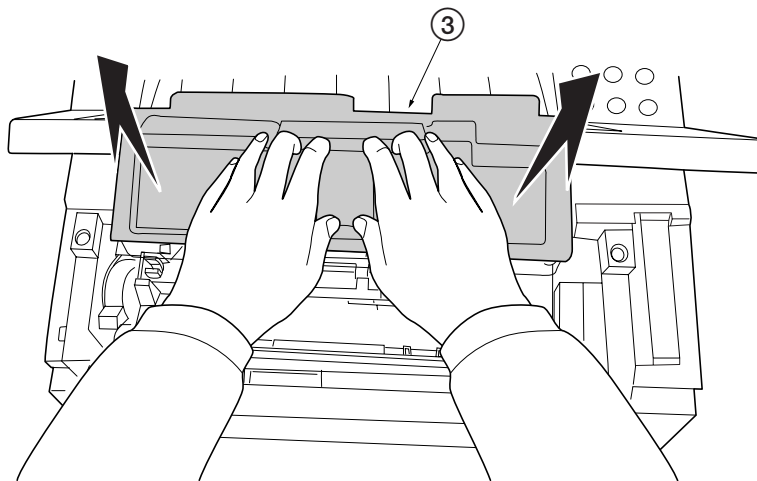

**Figure 3-1-2 Removing the old toner container**

Put it in the supplied plastic bag ④ and dispose of it.

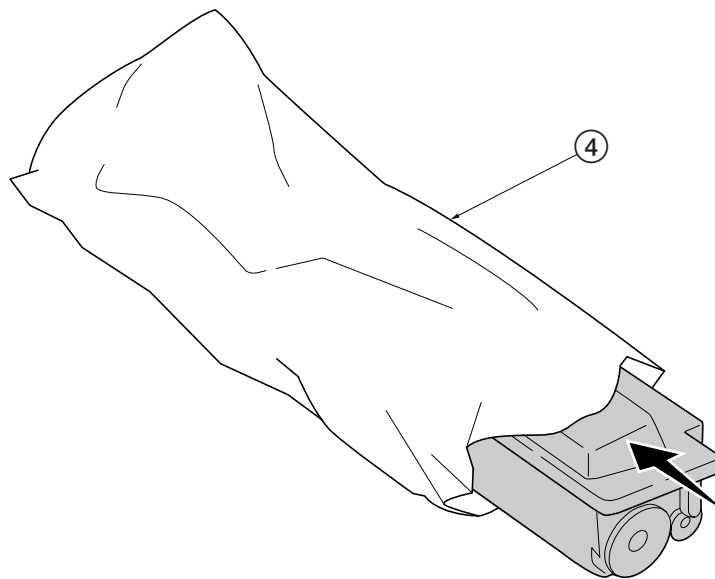

**Figure 3-1-3 Disposal of the old toner container**

**NOTE** Although the toner container is made from non-harmful, flammable material, be sure to dispose of it according to laws and regulations.

Proceed with the instructions provided in chapter 2, *Installing the toner container* on page 2-4 to complete installation of the new toner container.

#### **(4) Toner saver mode (*EcoPrint*)**

The *EcoPrint* enables to reduce the amount of toner consumed on the page so as to save printing costs by drastically extending the toner container life. *EcoPrint* mode is factory-set to off and turned on by using the operator panel (MENU) For details refer to the printer's *User's Manual*.

### 3-1-3 Cleaning the printer

To avoid print quality problems, the following printer parts must be cleaned with every toner container replacement.

To clean the printer, first, remove the process unit from the printer.

Open the top cover ① and front cover ②. Lift the process unit ③ together with the toner container out of the printer.

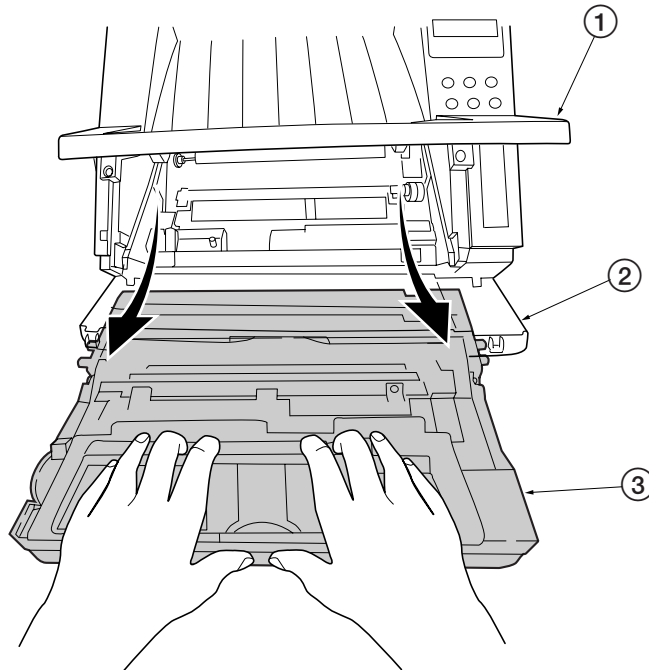

**Figure 3-1-4 Removing the process unit**

**NOTE**

The drum in the process unit is sensitive to light. Never expose the drum even to normal office lighting (500 lux) for more than five minutes.

### (1) Cleaning the registration roller

Use the supplied wiper cloth ① to clean dust and dirt away from the registration roller ② (metal).

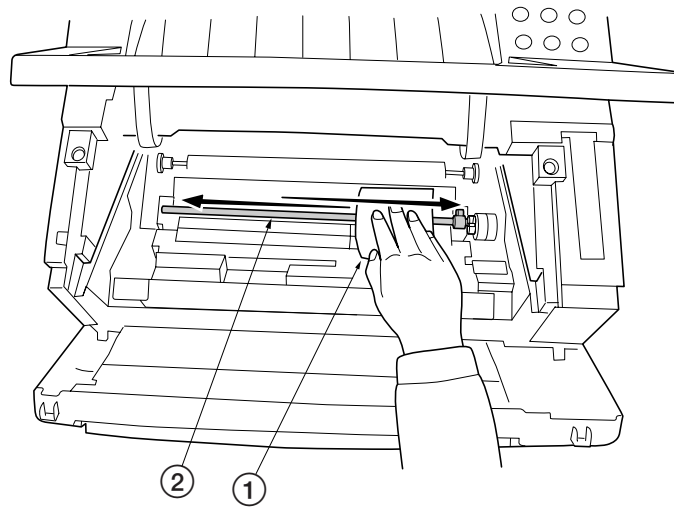

Figure 3-1-5 Cleaning the registration roller

### (2) Cleaning the main charger wire

Slide the charger cleaner knob (green colored) back and forth 2 to 3 times, then return it to its [CLEANER HOME POSITION].

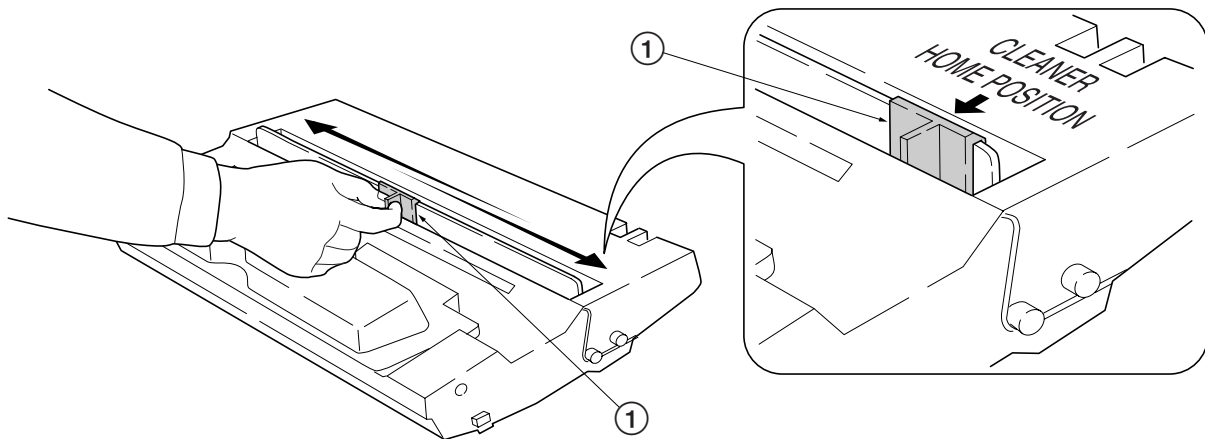

Figure 3-1-6 Cleaning the main charger wire

After cleaning is done, install the process unit in the printer, using the reverse manner as above. Close the front cover and top cover.

### 3-1-4 Updating the firmware

Updating the system (controller) firmware is possible by downloading the firmware through the parallel interface or through the memory card (CompactFlash). These firmware programs are directly overwritten in the system DIMM [board KP-893] (Flash ROM type only) on the main board. The operator panel message in different languages can also be downloaded through the parallel interface or through the memory card (CompactFlash).

#### (1) Firmware program data format

Kyocera supplies the following types of data for updating firmware of the different purposes:

- System firmware

The data to be downloaded are supplied in the following format:

System firmware file name example

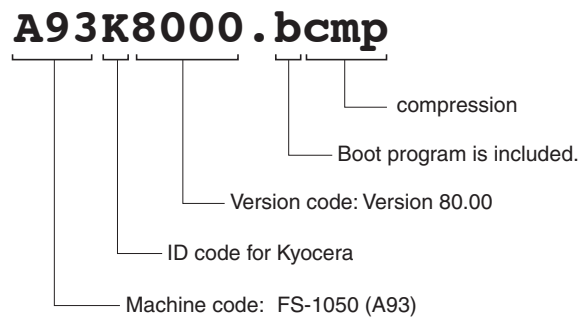

**Figure 3-1-9 Firmware program data format**

## (2) Downloading the firmware from the parallel interface

This section explains how to download firmware data from the parallel interface. The printer system can automatically recognize whether the data to be overwritten is for controller firmware.

### CAUTION



Downloading the firmware takes several minutes. Do not turn power off during downloading.

### NOTE

MS-DOS is required for a downloading from the parallel interface. The computer must be connected to the printer with a parallel cable.

- ① Turn power switch on.
- ② At the DOS prompt, send the command to the printer that engages the printer in the supervisor mode.
- ③ Copy the firmware data to the printer. (See the flow chart below)  
[System firmware ex. A93K8000 .bcmp ]

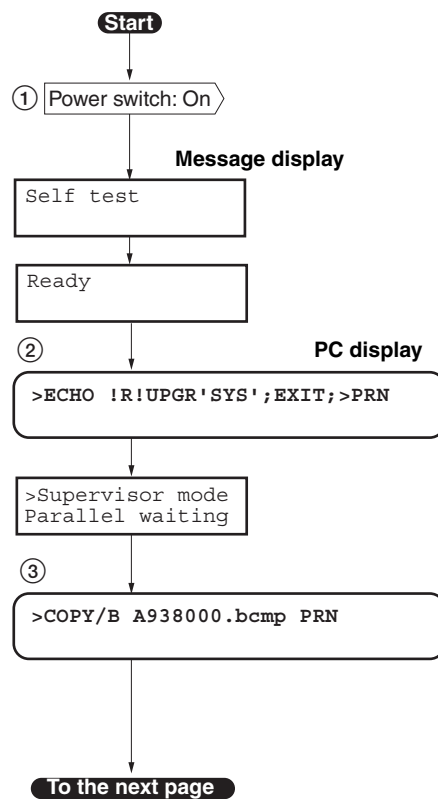

- ④ Supervisor mode. The parallel interface is waiting for the firmware data.
- ⑤ Receiving the firmware data.
- ⑥ The system DIMM or flash ROM is overwritten with the new firmware data.
- ⑦ Firmware downloading is finished. (When more than one data are down loaded, the data display can be changed by pressing any key.)
- ⑧ Turn power switch off and on.
- ⑨ Check the that printer gets Ready.

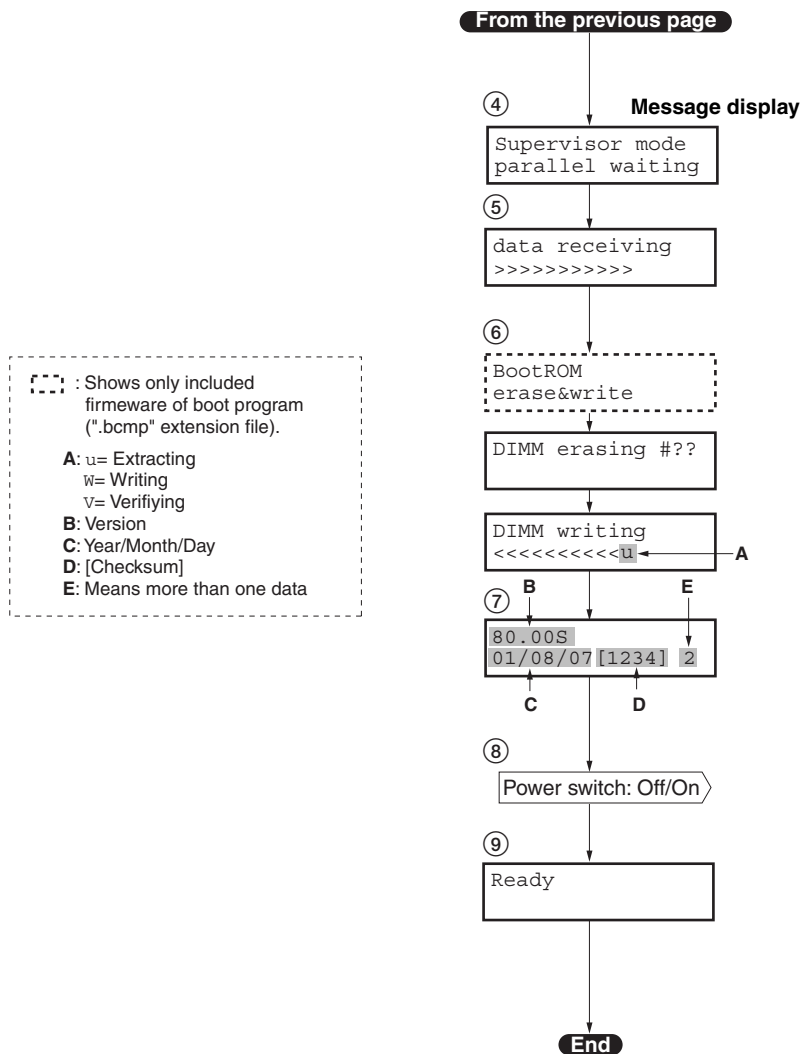

Confirm that the status page shows the new system firmware version (See *Appendix B* on page B-4). If the message display indicates download error, refer to section *Downloading errors* on page 3-14.



### (3) Downloading the firmware from the memory card

To download data written in a memory card (CompactFlash) to the printer, proceed as explained in this section.

#### CAUTION



Downloading firmware takes several minutes. Do not turn power off during downloading. If downloading is interrupted by an accidental power failure, etc., the system DIMM may have to be replaced.

#### NOTE

The firmware program data must be stored to the root directory of the memory card (CompactFlash).

- ① Turn power switch off.
- ② Remove the two screws and then remove the slot cover. Insert the memory card in the printer's memory card slot.
- ③ Turn power switch on.
- ④ The printer is automatically engaged in the supervisor mode.

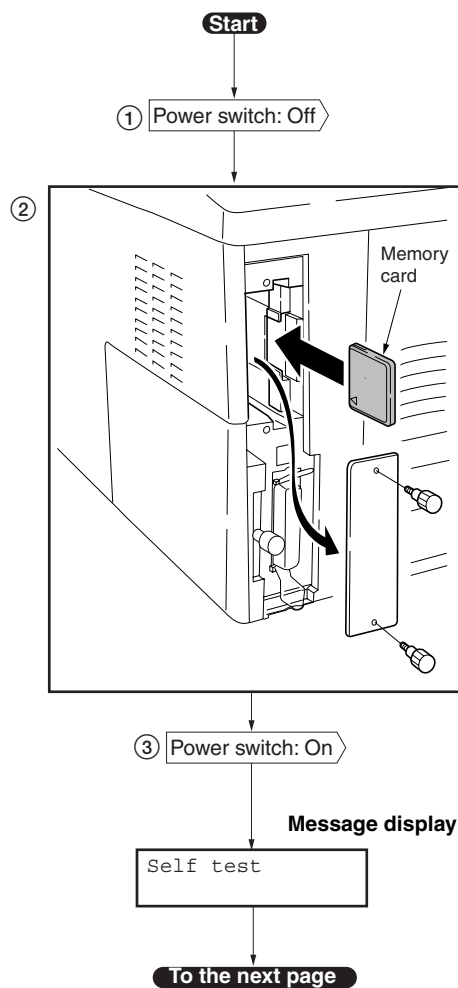

- ⑤ Data are transferred to the RAM on the main board.
- ⑥ The system DIMM or Flash ROM is overwritten with the new firmware data.
- ⑦ Firmware download is finished. (When more than one data are down loaded, the data display can be changed by pressing any key.)
- ⑧ Turn power switch off.
- ⑨ Remove the memory card and then secure the slot cover by using two screw.
- ⑩ Turn power switch on.
- ⑪ Check the printer gets Ready.

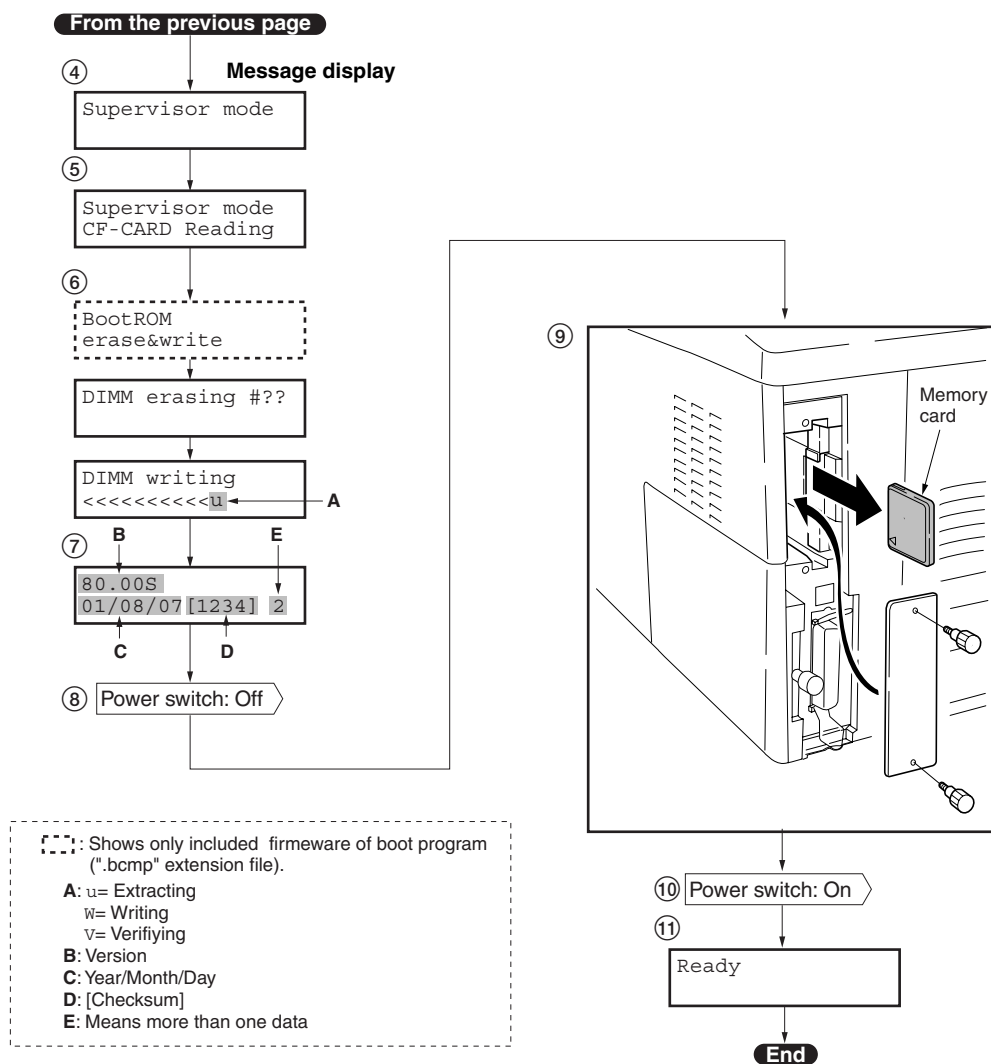

Confirm that the status page shows the new system firmware version (See *Appendix B* on page B-4). If the message display indicates download error, refer to section *Downloading errors* on page 3-14.

#### (4) Downloading errors

The following messages are indicated on the message display when an error occurred during downloading the firmware data.

Error message	Description	Corrective action
<div style="border: 1px solid black; padding: 2px; width: fit-content;">download header error [##]</div> <p>##: Error code 20 to 26.</p>	Deficit of the file header ----- Deficit of the data header ----- File checksum error ----- Data checksum error ----- File header version error ----- Data header version error	Obtain the correct firmware.
<div style="border: 1px solid black; padding: 2px; width: fit-content;">system download error [##]</div> <p>##: Error code 40 to 59.</p>	Incompatibility of firmware and system DIMM board ----- Defective system DIMM board	Confirm whether the firmware is applicable to this printer. ----- Replace the system DIMM board.
<div style="border: 1px solid black; padding: 2px; width: fit-content;">receive error [##]</div> <p>##: Error code 80 or 81.</p>	Improper connection of parallel cable between PC and printer ----- Defective parallel cable	Check the contact between PC and the printer's interface connector. ----- Replace the parallel cable.

If the corrective action above does not solve the problem, replace engine board (KP-882). See page 5-11.

## **Chapter 4    Operation   Overview**

## Chapter 4 Contents

<b>4-1 Electrophotographic system</b> .....	<b>4-3</b>
4-1-1 Electrophotographic cycle .....	4-3
Process unit mechanism .....	4-4
(1) Main charging .....	4-5
Photo conductive drum .....	4-5
Charging the drum .....	4-6
(2) Exposure .....	4-7
Laser scanner unit .....	4-8
Drum surface potential .....	4-9
(3) Development .....	4-10
(4) Transfer .....	4-11
(5) Fusing .....	4-12
Fuser unit mechanism .....	4-13
(6) Cleaning .....	4-14
<b>4-2 Paper feeding system</b> .....	<b>4-15</b>
4-2-1 Paper feed control .....	4-16
Paper feeding mechanism .....	4-17
<b>4-3 Electrical control system</b> .....	<b>4-18</b>
4-3-1 Electrical parts layout .....	4-18
4-3-2 Operation of circuit boards .....	4-19
(1) Main board .....	4-19
(2) Engine board .....	4-20
Eraser lamp control circuit .....	4-21
Polygon motor control circuit .....	4-25
(3) Power supply board .....	4-26
(4) Bias board .....	4-27
(5) High voltage board .....	4-28
Interlock switch .....	4-29

## 4-1 Electrophotographic system

Electrophotography is the technology used in laser printing which transfer data representing texts or graphics objects into a visible image which is developed on the photosensitive drum, finally fusing on paper, using light beam generated by a laser diode.

This section provides technical details on the printer's electrophotography system.

### 4-1-1 Electrophotographic cycle

The electrophotography system of the printer performs a cyclic action made of six steps as follows. Each step is technically explained in the following sections.

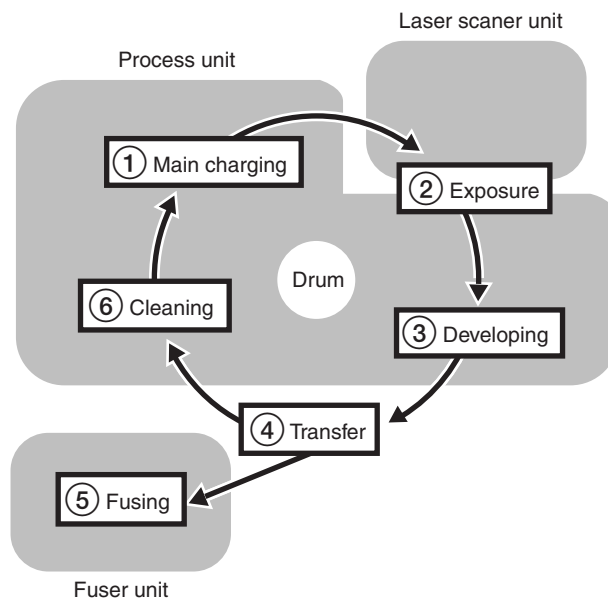

**Figure 4-1-1 Electrophotographic cycle**

The sections for main charging, exposure (drum), developing, and cleaning are modularized in one Process unit PU-42.

# Process unit mechanism

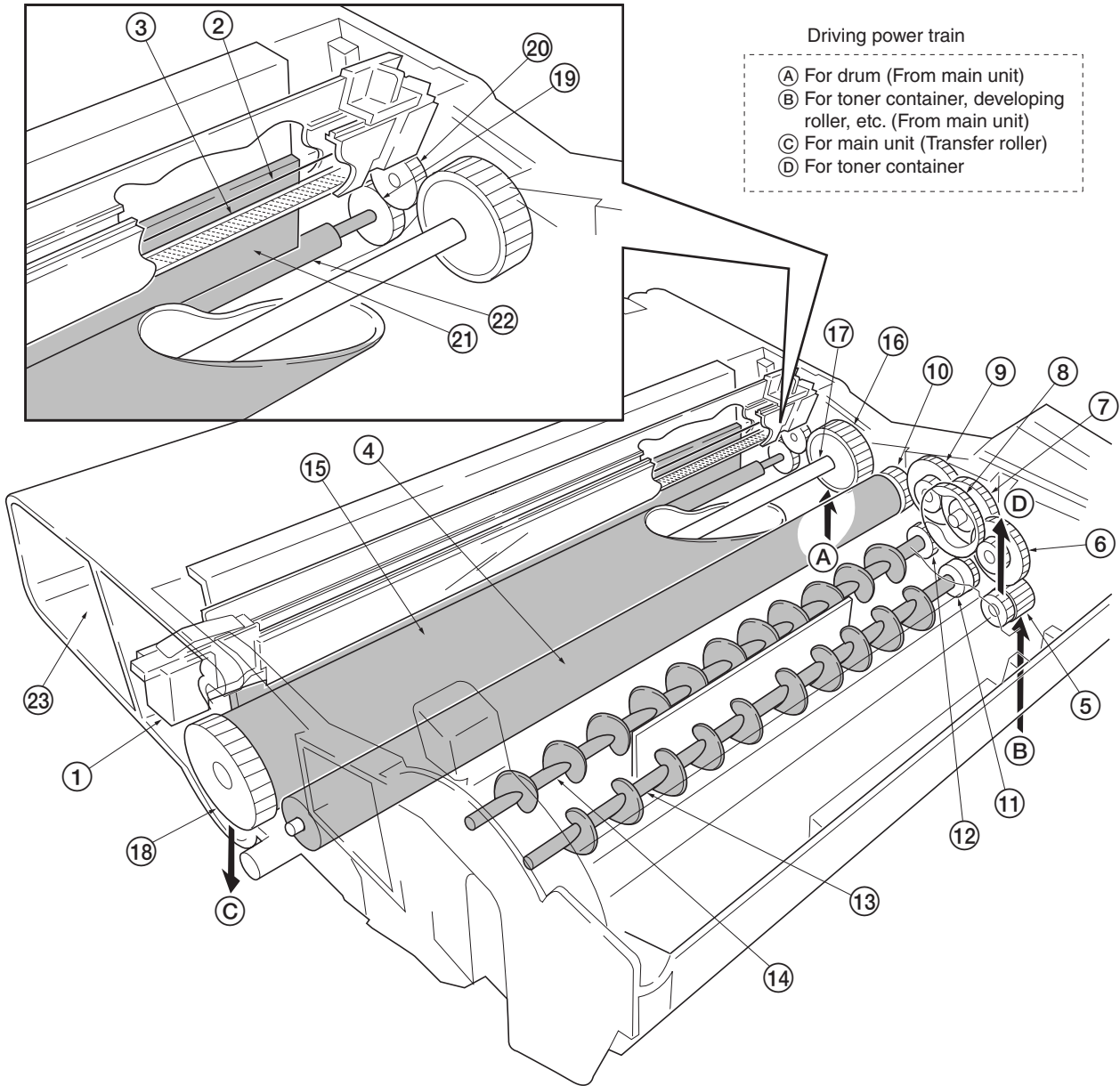

Driving power train

- (A) For drum (From main unit)
- (B) For toner container, developing roller, etc. (From main unit)
- (C) For main unit (Transfer roller)
- (D) For toner container

- |                     |                    |                         |
|---------------------|--------------------|-------------------------|
| ① Main charger unit | ⑨ Gear Z18-Z35H    | ⑰ Drum shaft            |
| ② Charger wire      | ⑩ MAG gear Z24H    | ⑱ Drum gear Z36         |
| ③ Grid              | ⑪ Mixer gear Z20 B | ⑲ Sweep gear Z13        |
| ④ Developing roller | ⑫ Mixer gear Z20 A | ⑳ Idle gear 18H         |
| ⑤ Gear Z14-Z18      | ⑬ DLP screw B      | ㉑ Cleaning blade        |
| ⑥ Gear Z14-Z36      | ⑭ DLP screw A      | ㉒ Sweep roller          |
| ⑦ Gear Z18-Z36      | ⑮ Drum             | ㉓ Waste toner reservoir |
| ⑧ Free gear Z40     | ⑯ Drum gear Z35H   |                         |

**Figure 4-1-2 Process unit mechanism**

## (1) Main charging

### Photo conductive drum

The durable layer of organic photoconductor (OPC) is coated over the aluminum cylinder base. The OPC tend to reduce its own electrical conductance when exposed to light. After a cyclic process of charging, exposure, and development, the electrostatic image is constituted over the OPC layer. Since the OPC is materialized by resin, it is susceptible to damage caused by sharp edges such as a screwdriver, etc., resulting in a print quality problem. Also, finger prints can cause deterioration of the OPC layer, therefore, the drum (in the process unit) must be handled with care. Substances like water, alcohol, organic solvent, etc., should be strictly avoided.

As with all other OPC drums, the exposure to a strong light source for a prolonged period can cause a print quality problem. The limit is approximately 500 lux for less than five minutes. If the drum (process unit) remains removed form the printer, it should be stored in a cool, dark place.

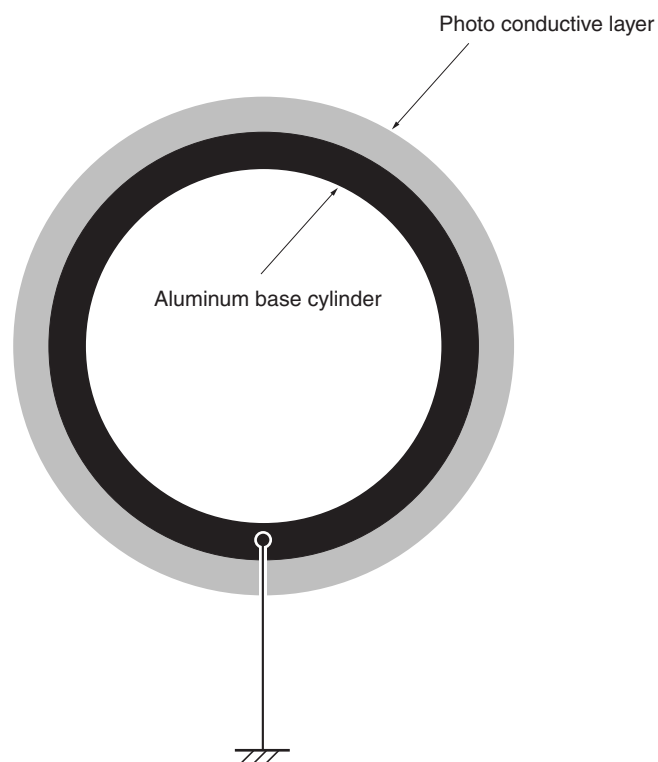
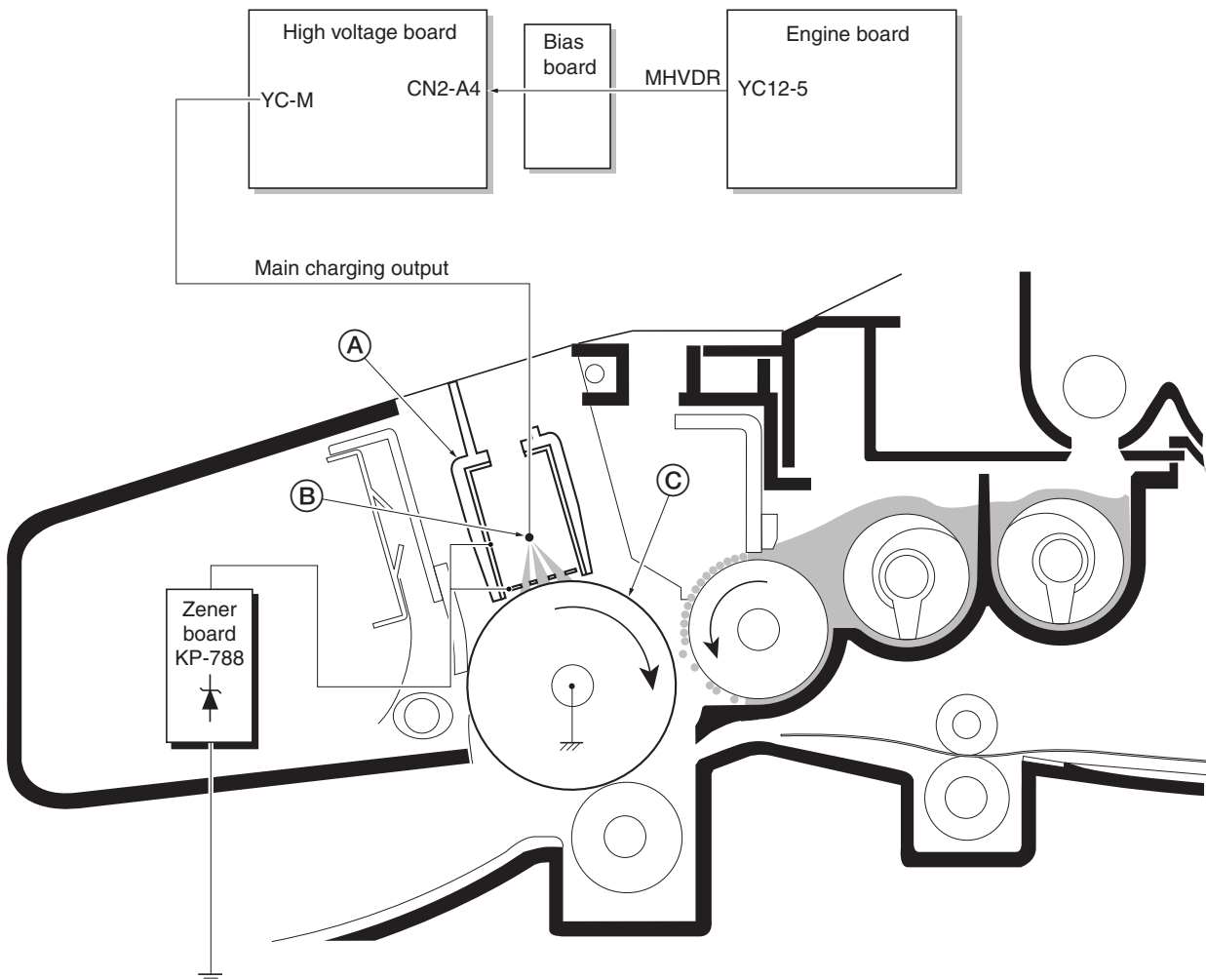

**Figure 4-1-3 Photo conductive drum**



## Charging the drum

The following shows a simplified diagram of the electrophotographic components in relation to the engine system. Charging the drum is done by the main charger unit (A).



**Figure 4-1-4 Charging the drum**

As the drum (C) rotates in a “clean (neutral)” state, its photoconductive layer is given a uniform, positive (+) corona charge dispersed by the main charger wire (B).

Due to high-voltage scorotron charging, the charging wire can get contaminated by oxidization after a long run. Therefore, it must be cleaned periodically from time to time using the method explained in chapter 3. Cleaning the charging wire prevents print quality problems such as black streaks.

## (2) Exposure

The charged surface of the drum (A) is then scanned by the laser beam from the laser scanner unit (B).

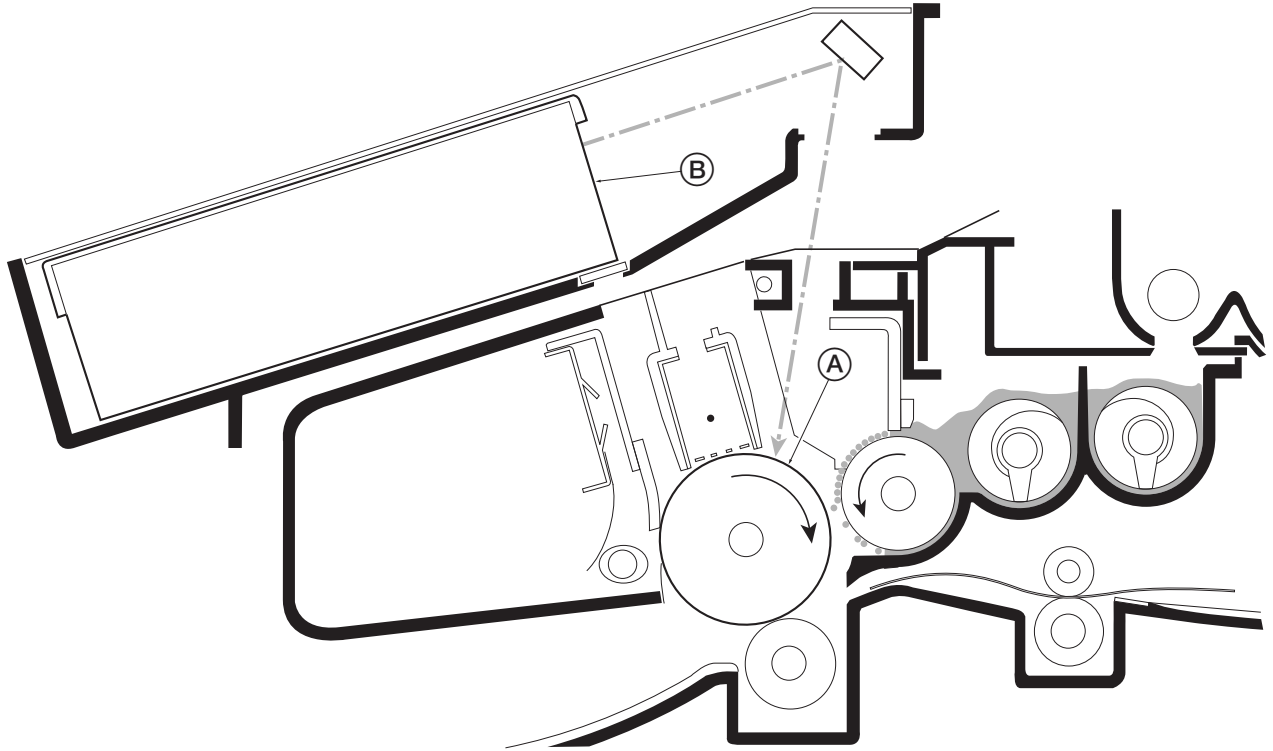

**Figure 4-1-5 Exposure**

The laser beam (780 nm wavelength) beam is dispersed as the polygon motor (polygon mirrors) revolves to reflect the laser beam over the drum. Various lenses and mirror are housed in the scanner unit, adjust the diameter of the laser beam, and focalize it at the drum surface.

## Laser scanner unit

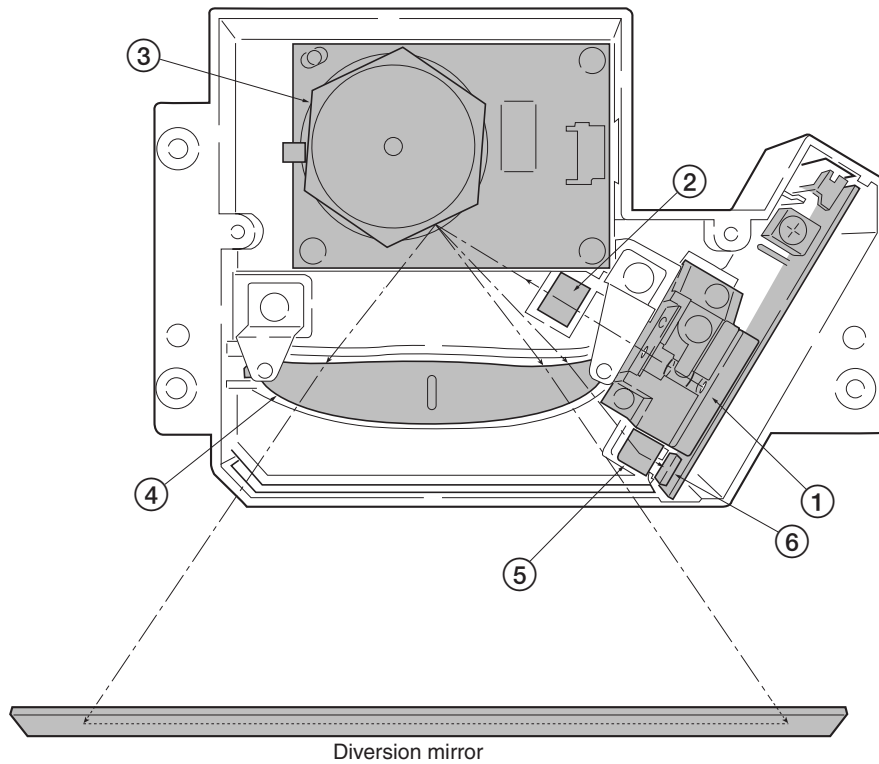
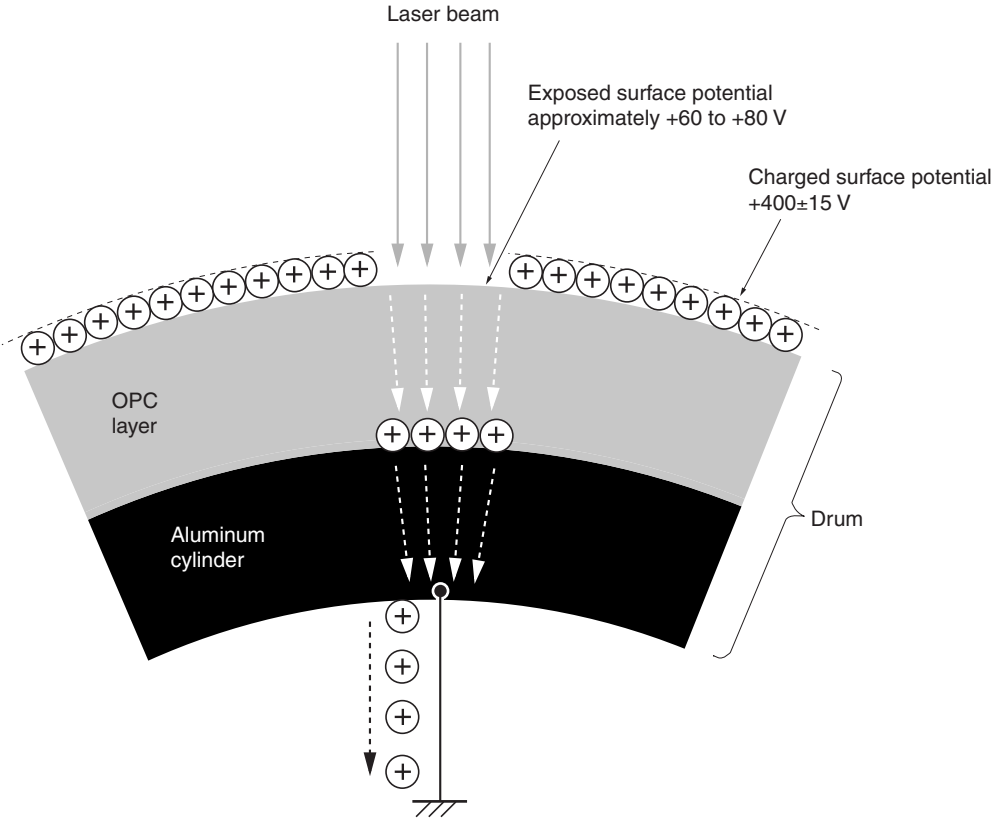

**Figure 4-1-6 Laser scanner unit**

Name	Description
① Laser diode	Emits diffused, visible laser.
② Cylindrical lens	Compensates the vertical angle at which the laser beam hits a polygon mirror segment.
③ Polygon mirror (motor)	Has six mirror segments around its hexagonal circumference; each mirror corresponding to one scanned line width on the drum when laser beam scans on it.
④ F-theta lens	The f-theta lens equalizes focusing distortion on the far ends of the drum.
⑤ Sensor mirror	Bends the very first shot of a laser scan towards the beam detection sensor (⑥).
⑥ Pin photo sensor	When shone by the sensor mirror above, this photo-sensor generates a trigger signal for the engine controller to start activating the paper feeding system.

**Drum surface potential**

The laser beam is continually switched on and off depending on the print data. It is on for a black (exposed) dot and off for a white (blank) dot. Since the drum surface is evenly charged, whenever it is illuminated by the laser beam, the electrical resistance of the photoconductor is reduced and the potential on the photoconductor is also lowered. Resulted on the drum surface is an electrostatic image which represents the data to print. Note that the area to be printed black has the low potential, constituting a “positively exposed” image.



**Figure 4-1-7 Drum surface potential**

### (3) Development

The latent image constituted on the drum is developed into a visible image. The developing roller (A) contains a 3-pole (S-N-S) magnet core (B) and an aluminum cylinder rotating around the magnet core (B). Toner attracts to the developing roller (A) since it is powdery ink made of black resin bound to iron particles. Doctor blade (C), magnetized by magnet (D), is positioned approximately 0.3 mm above the developing roller (A) to constitute a smooth layer of toner in accordance with the roller revolution.

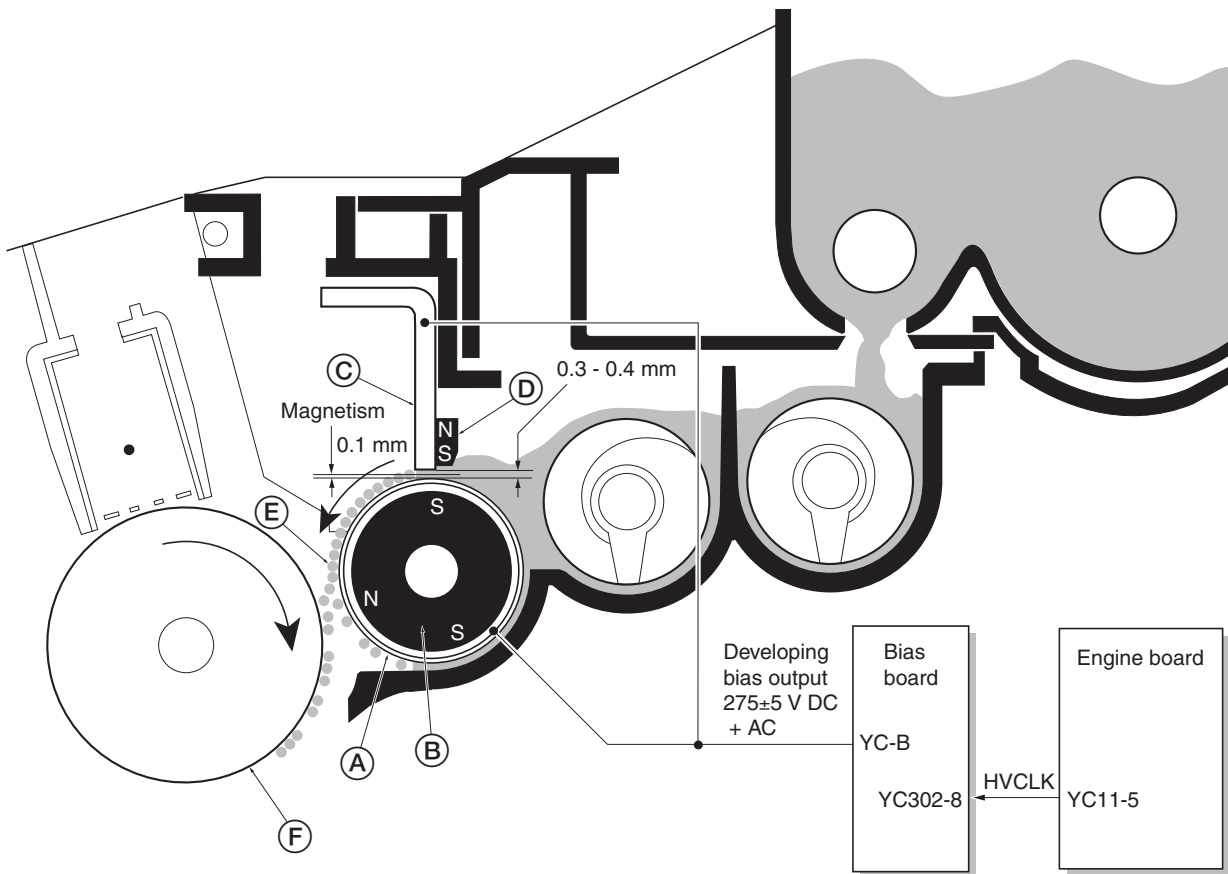

**Figure 4-1-8 Development**

The developing roller (A) is applied with the AC-weighted, positive DC power source. Toner (E) on the developing roller (A) is given a positive charge. The positively charged toner (E) is then attracted to the areas of the drum (F) which was exposed to the laser light. (The gap between the drum (F) and the developing roller (A) is approximately 0.3 mm.) The non-exposed areas of the drum (F) repel the positively charged toner as these areas maintain the positive charge.

The developing roller (A) is also AC-biased to ensure contrast in yielding by compensating the toner's attraction and repelling action during development.

#### (4) Transfer

The image developed by toner on the drum (A) is transferred onto the paper because of the electrical attraction between the toner itself and the transfer roller (B). The transfer roller is negatively biased so that the positively charged toner is attracted onto the paper while it is pinched by the drum and the transfer roller.

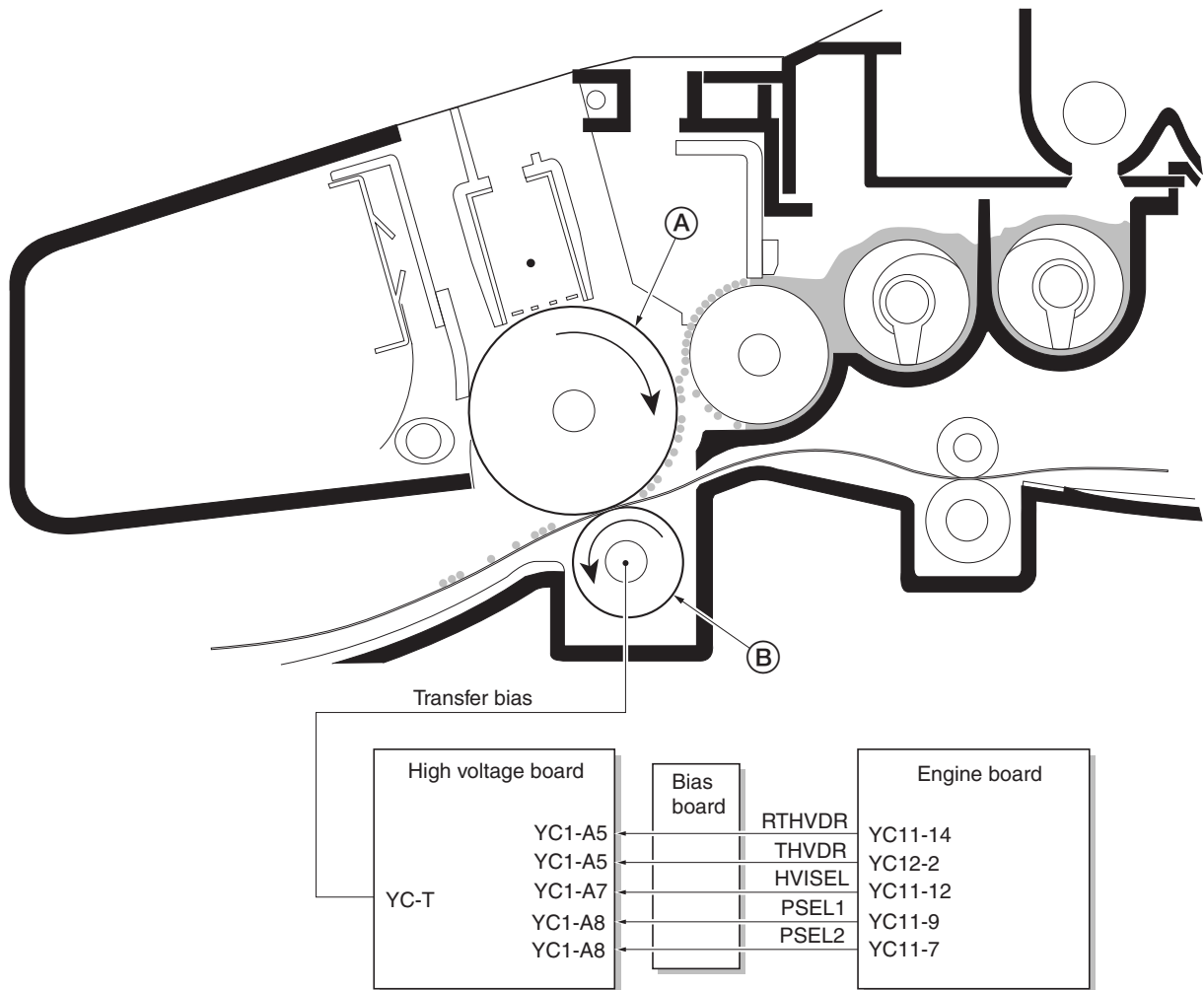
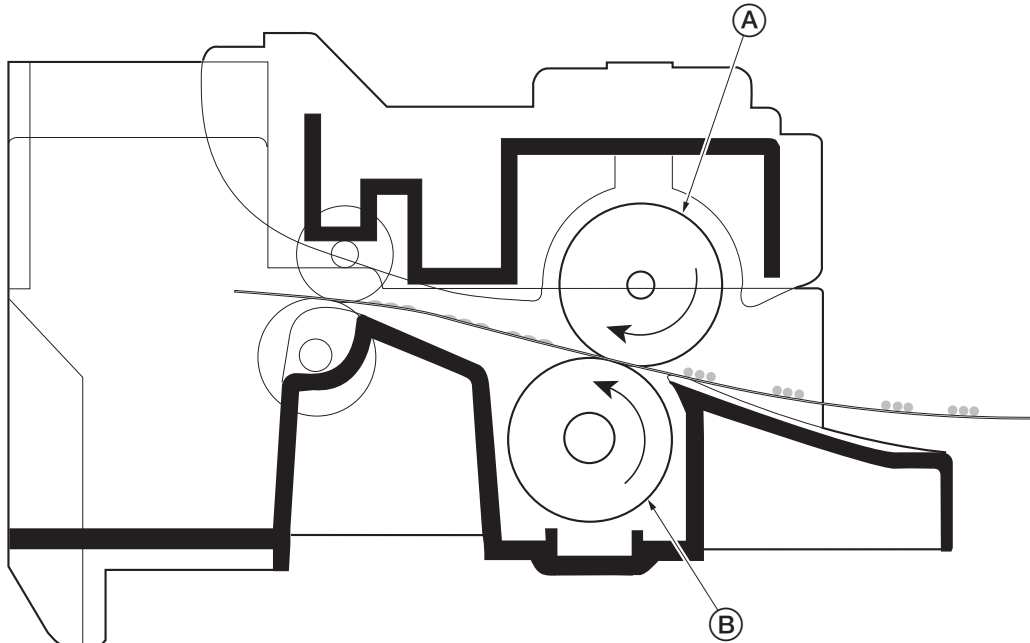

**Figure 4-1-9 Transfer**

The nominal transfer bias is set to approximately -1.8 kV (limit) with the -6  $\mu$ A current. Since the ideal potential of the transfer bias depends on the thickness of paper, the bias is raised to approximately -2.5 kV/-6  $\mu$ A for thicker paper. On the other hand, the bias current is reduced to -1.8 kV/-6  $\mu$ A for thin paper.

## (5) Fusing

The toner on the paper is molten and pressed into the paper as it passes between the heat roller (A) and the press roller (B) in the fuser unit.



**Figure 4-1-10 Fusing**

The heat roller has a halogen lamp inside which continuously turns on and off by the thermistor to maintain the constant temperature onto the heat roller surface. The temperature is approximately 160 °C while the printer is idle; approximately 175 °C (Normal paper) and 185 °C (Thick paper) while printing.

The heat roller is resin coated by fluorin to prevent toner from accumulating on the roller after a long run. Care must be taken while handling the heat roller not to scratch the roller surface as doing so may result in print problems.

The heat roller has four claws which are continuously in contact with its surface. These claws prevent the paper on which toner has been fused from being wound around the heat roller causing paper jam.

The pressure roller is made of the heat-resistant silicon rubber. This roller is used to strongly press the paper towards the heat roller by means of coil springs.

The temperature of the heat roller is constantly monitored by the engine board using the thermistor and triac. Should the temperature of the heat roller exceed the predetermined value, the thermal cutout is activated to effectively disconnect the heater (halogen) lamp from power.

**Fuser unit mechanism**

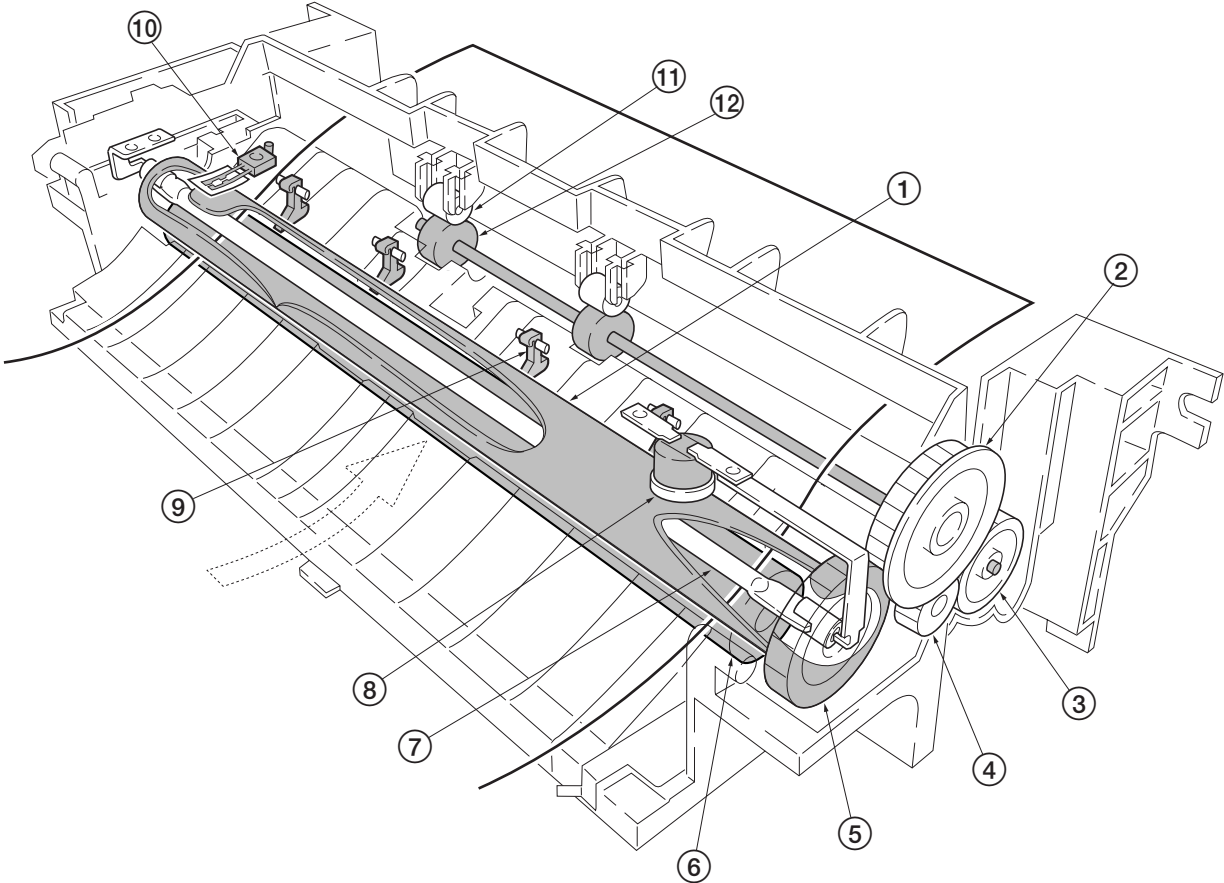

- ① Heat roller
- ② Idle gear Z34
- ③ Exit gear Z23
- ④ Idle gear Z18
- ⑤ Heat gear Z33
- ⑥ Press roller
- ⑦ Heater lamp [500±25 W]
- ⑧ Thermal cutout
- ⑨ Separator(s)
- ⑩ Thermistor
- ⑪ Exit pulley(s)
- ⑫ Lower exit roller

**Figure 4-1-11 Fuser unit mechanism**



## (6) Cleaning

After the transferring process, the drum needs to be physically cleaned of toner which is residual after the development process. The cleaning blade (A) is constantly pressed against the drum (B) and scrapes the residual toner off to the sweep roller (C). The waste toner is collected at the output end of the sweep roller (C) and sent back to the toner container, into the waste toner reservoir (D).

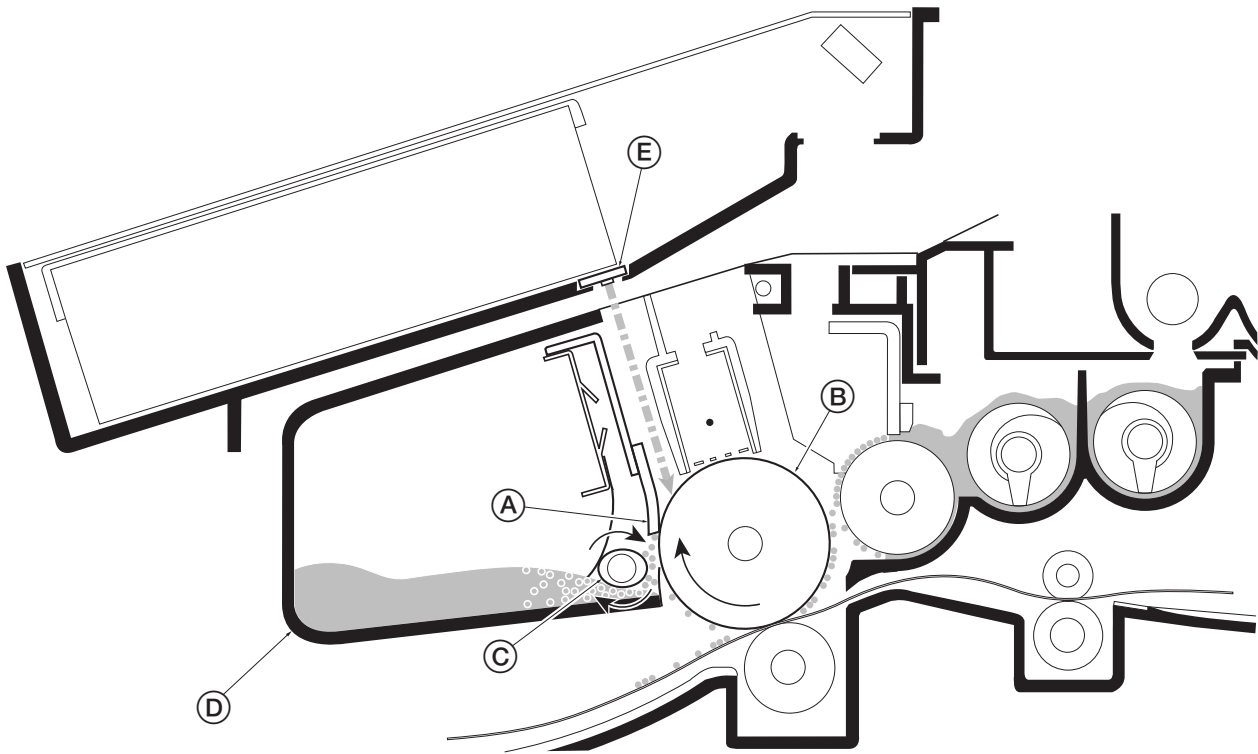

**Figure 4-1-12 Drum cleaning and erasing static charge**

After the drum (B) is physically cleaned, it then must be cleaned to the electrically neutral state. This is necessary to erase any residual positive charge, ready to accept the uniform charge for the next print process. The residual charge is canceled by exposing the drum (B) to the light emitted from the eraser lamp (E). This lowers the electrical conductivity of the drum surface making the residual charge on the drum surface escape to the ground.

## 4-2 Paper feeding system

The paper feeding system picks up paper from the cassette, MP tray, or if installed, the paper feeder PF-17, feeds it in the printer, and delivers in the output tray. Paper is fed at the precise timing in synchronization with data processing. The paper feeding system finally delivers the printed page to either the face-down or face-up tray as manipulated by the user.

The figure below shows the components in the paper feeding system and the paths through which the paper travels. The sensors, clutches, etc., are described in the following pages.

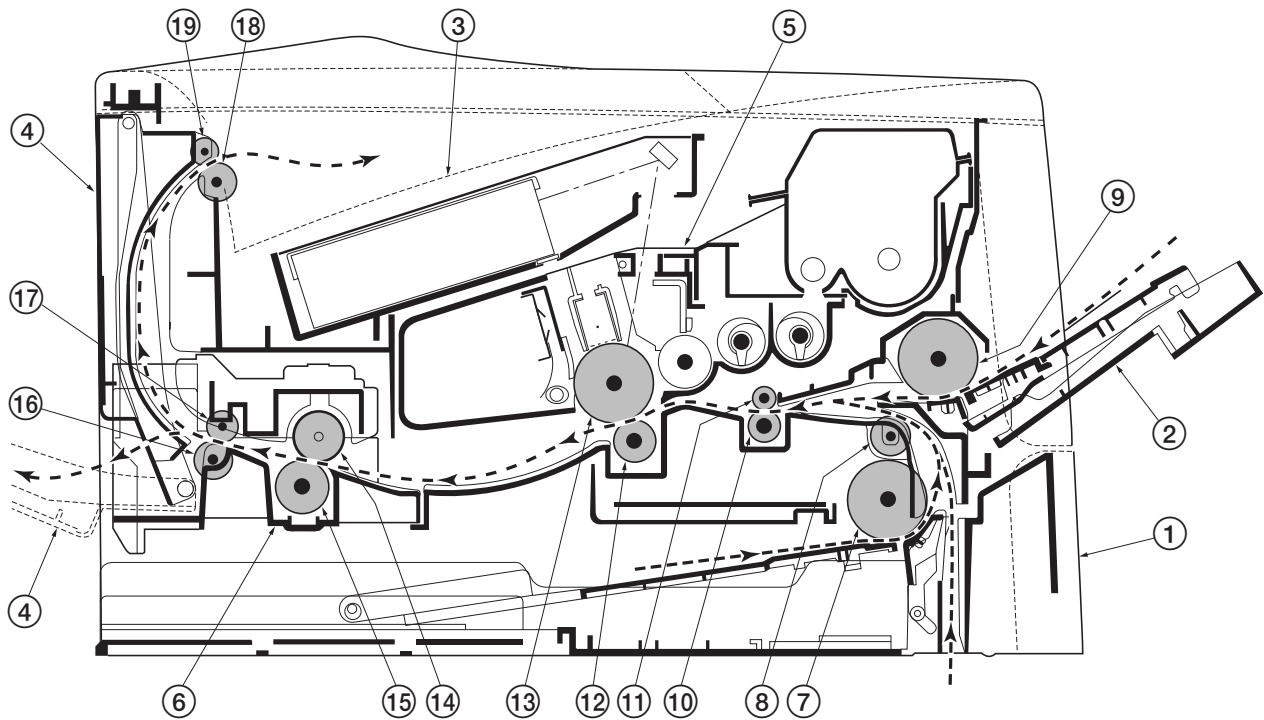

- |                         |                             |                     |
|-------------------------|-----------------------------|---------------------|
| ① Cassette              | ⑧ Feed pulley               | ⑮ Press roller      |
| ② MP tray               | ⑨ MP feed roller            | ⑯ Lower exit roller |
| ③ Face-down output tray | ⑩ Lower registration roller | ⑰ Exit pulley       |
| ④ Face-up output tray   | ⑪ Upper registration roller | ⑱ Upper exit roller |
| ⑤ Process unit          | ⑫ Transfer roller           |                     |
| ⑥ Fuser unit            | ⑬ Drum                      |                     |
| ⑦ Feed roller           | ⑭ Heat roller               |                     |

**Figure 4-2-1 Paper feeding path**

### 4-2-1 Paper feed control

The following diagram shows interconnectivity of the feeding system components including the sensors and rollers. The engine board provides the signals in conjunction with the electrophotography process that is driven by the main board.

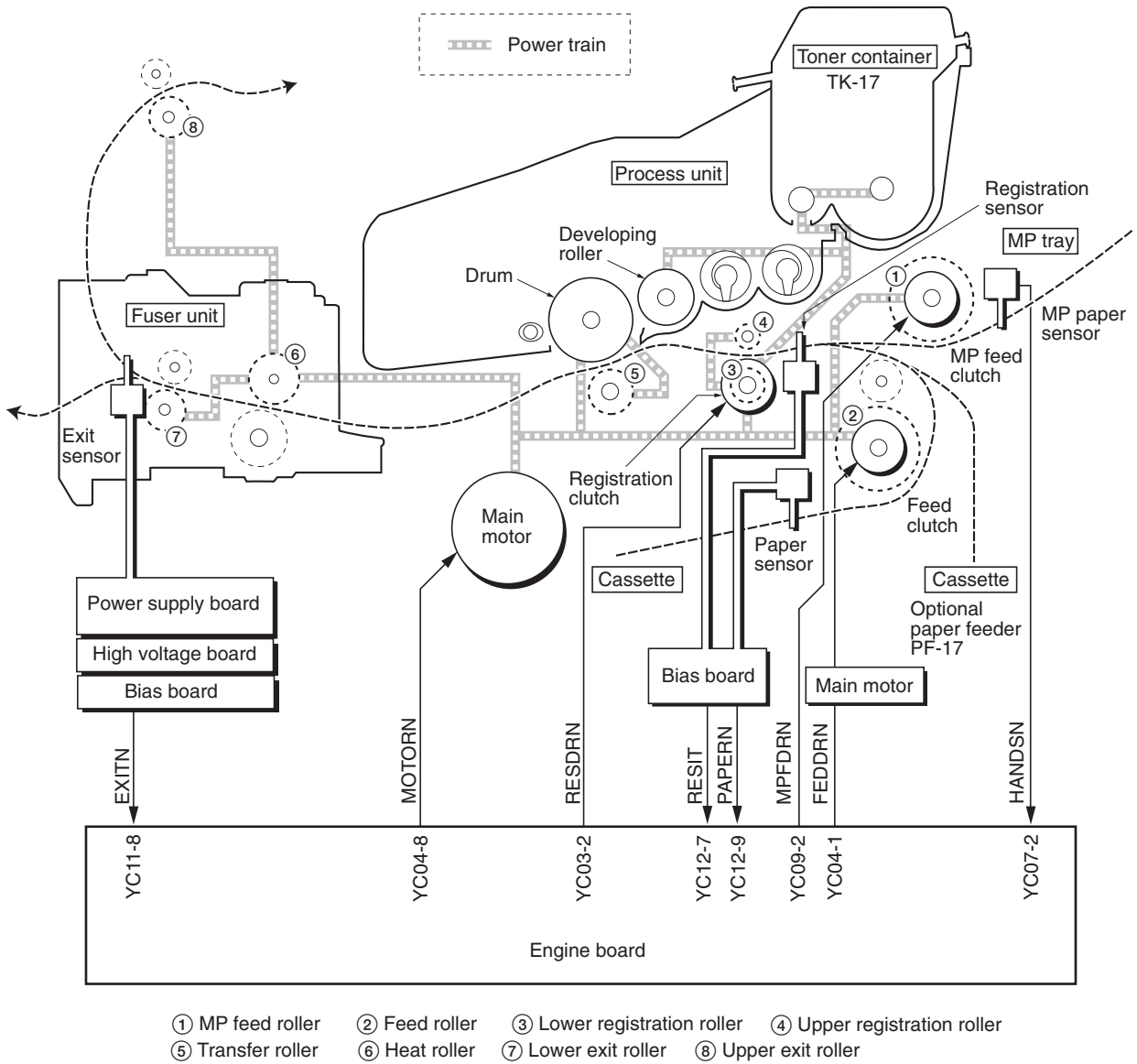

**Figure 4-2-2 Paper feed control**

# Paper feeding mechanism

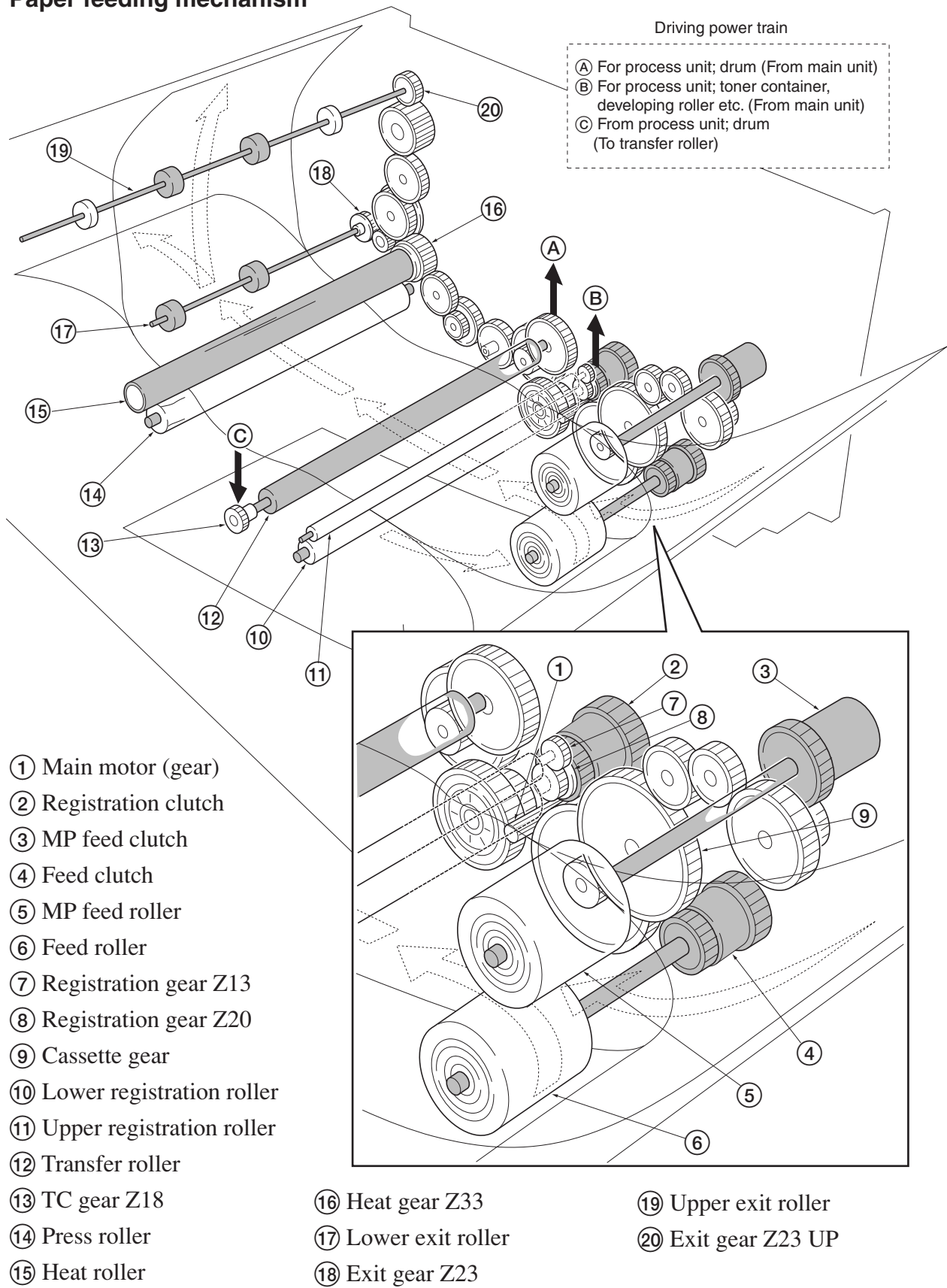

**Figure 4-2-3 Paper feeding mechanism**

## 4-3 Electrical control system

### 4-3-1 Electrical parts layout

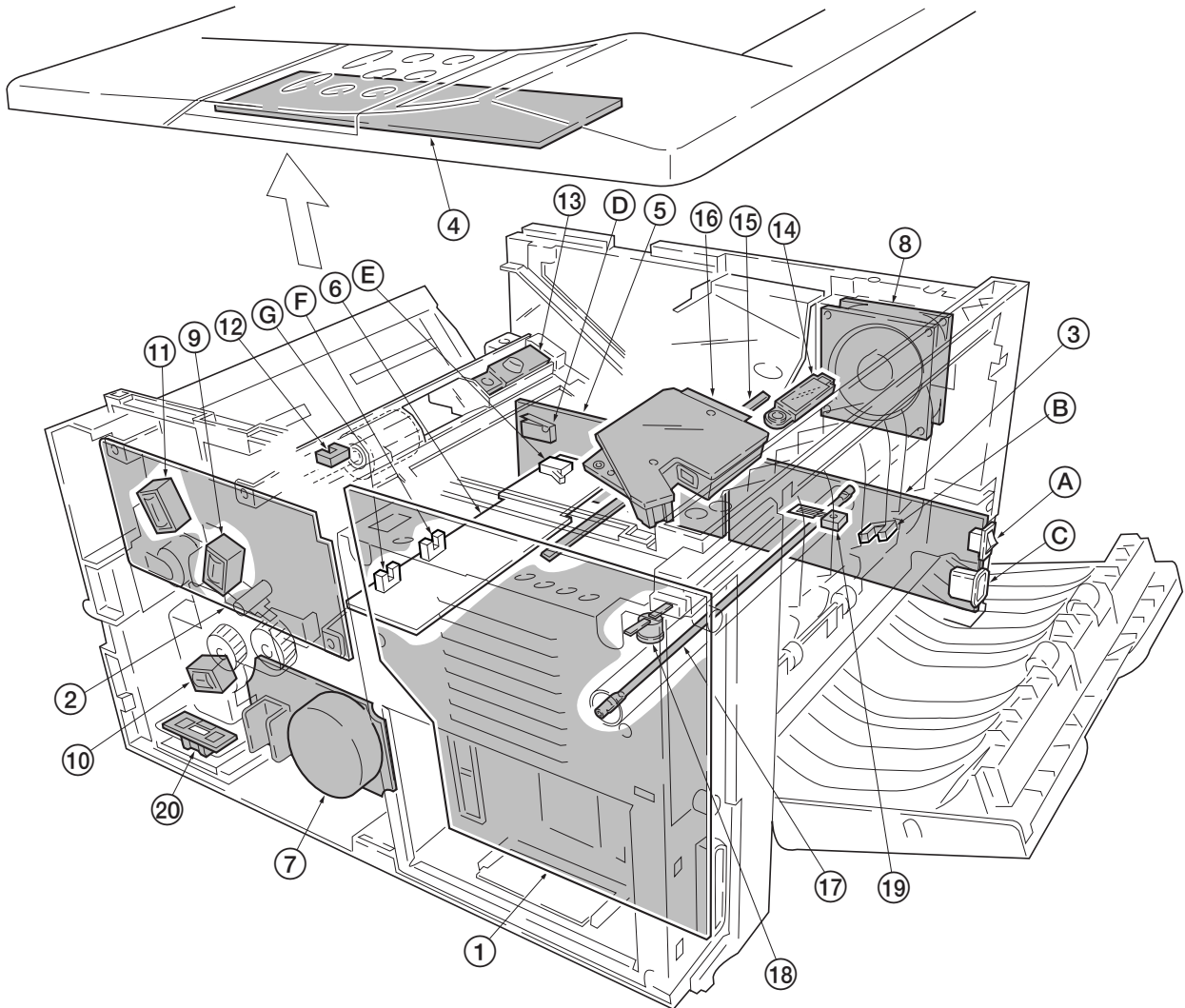

- |                                 |                       |                                    |
|---------------------------------|-----------------------|------------------------------------|
| ① Main board (KP-888)           | ⑥ Bias board (KP-884) | ⑫ MP paper sensor                  |
| ② Engine board (KP-882)         | ⑤ Cassette switch     | ⑬ Toner sensor                     |
| ③ Power supply board            | ④ Registration sensor | ⑭ Waste toner sensor               |
| ① Power switch                  | ⑦ Paper sensor        | ⑮ Eraser lamp                      |
| ② Exit sensor                   | ⑧ Main motor          | ⑯ Laser scanner unit               |
| ③ Inlet                         | ⑨ Cooling fan         | ⑰ Heater lamp                      |
| ④ LCD controller board (KP-886) | ⑩ Registration clutch | ⑱ Thermal cutout                   |
| ⑤ High voltage board            | ⑪ Feed clutch         | ⑲ Thermistor                       |
| ④ Interlock switch              | ⑫ MP feed clutch      | ⑳ Paper feeder interface connector |

**Figure 4-3-1 Electrical parts layout**

## 4-3-2 Operation of circuit boards

### (1) Main board

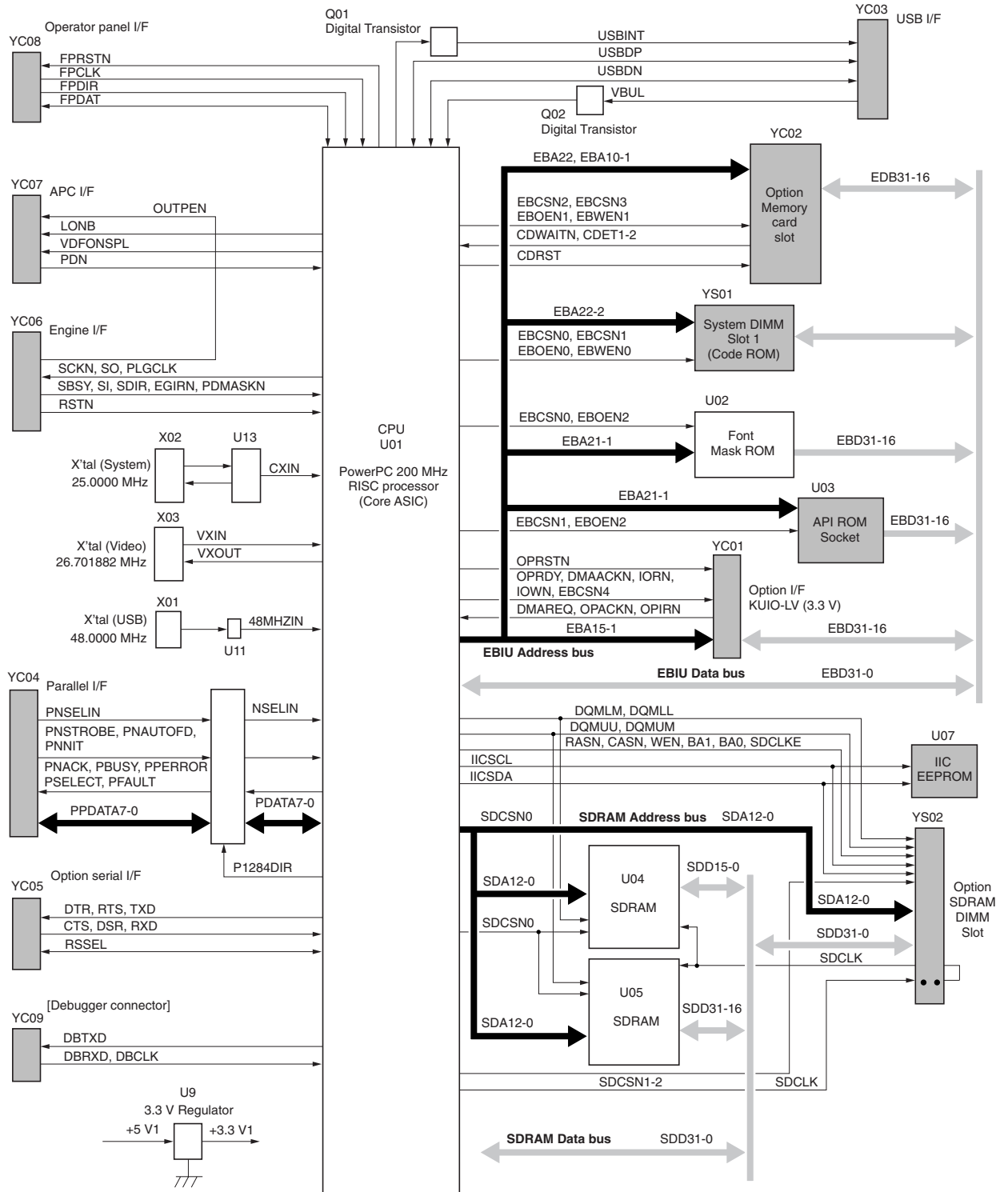
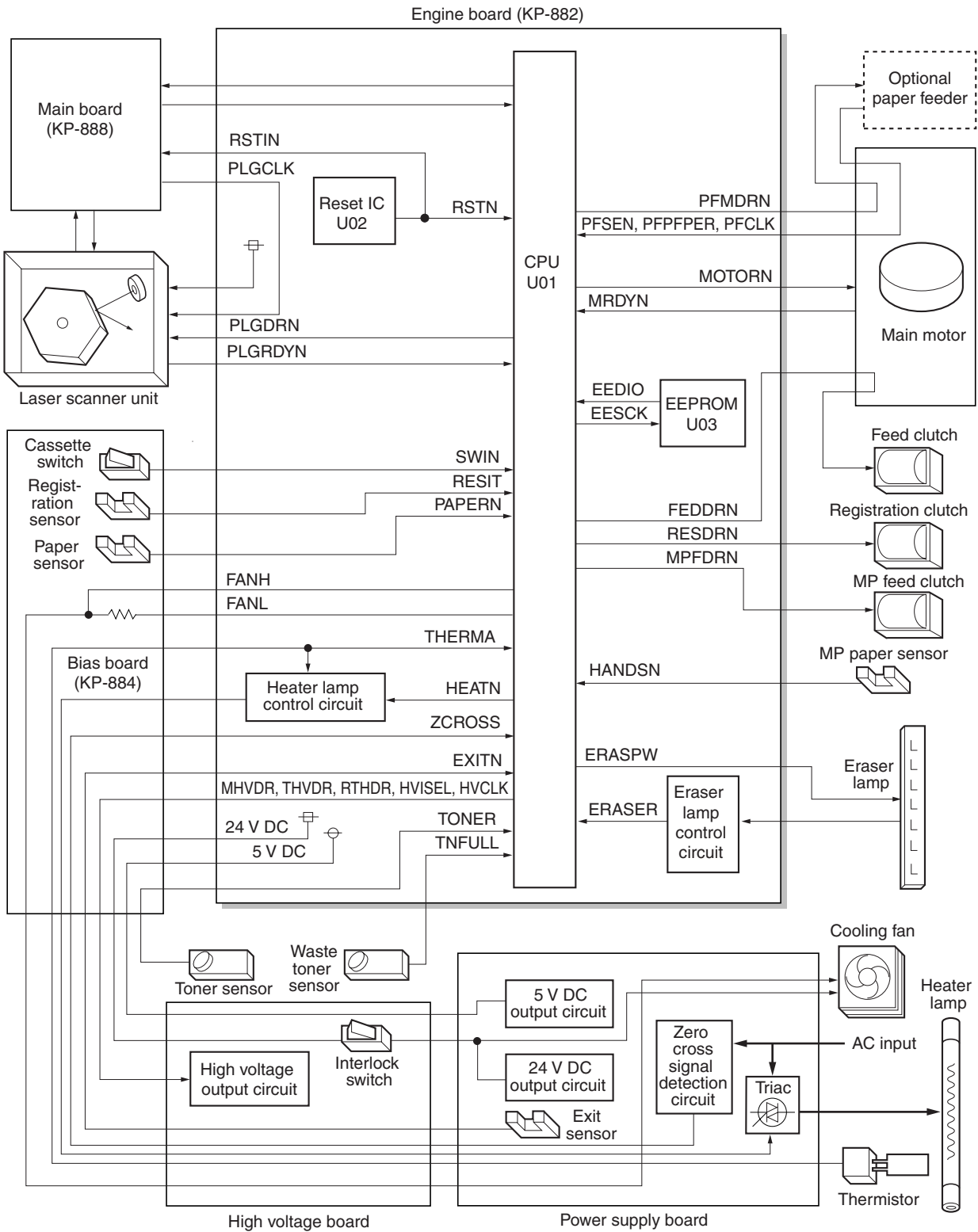

Figure 4-3-2 Main board circuit block diagram

## (2) Engine board



**Figure 4-3-3 Engine board circuit block diagram**

## Eraser lamp control circuit

The CPU (U01) turns pin #23 (ERASERN) of U01 to H level, transistors (Q16 and Q14) turns on consequently, and the 24 V DC given at pin #1 of connector YC05 applies to the eraser lamps. The eraser lamps thus illuminate as the current flows through the eraser lamp, the pin #2 of connector YC05, resistors (R75/R76, and R77/R78), and the ground.

Pin #27 (ERRDYN) of the CPU (U01) is wired to the crossing of resistors (R75/R26 and R77/R78) via resistor (R74). The U01 turns pin #23 (ERASERN) to H level and monitors the input level after one second. If the eraser lamp is normal, the current flowing through R74 also flows the zener diode (DZ01), making the voltage at pin #27 to be approximately 3.7 V. On the contrary, if the level at pin #27 (ERRDYN) is less than 1 V for more than 2 seconds, despite the U01 turns pin #23 (ERASERN) to H level and applying the 24 V DC to pin #1 of connector YC05, the U01 recognizes that the current is not flowing through the eraser lamp. The message “Call service 5300” is then displayed.

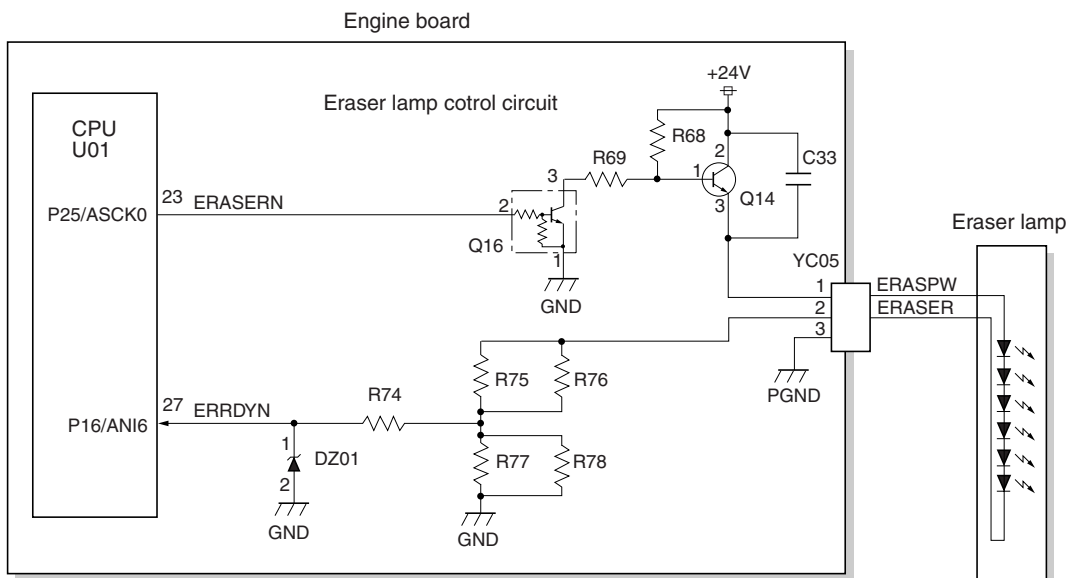

Figure 4-3-4 Eraser lamp control circuit



## Heater lamp control circuit

Activation of the heater lamp is dominated by the HEAT signal which is derived by the engine CPU (U01) at its pin #1. When its level is high, transistor QA03-a turns on, photo-triac PC2 and triac TRC1 turn on simultaneously, and the heater lamp is applied with the primary AC voltage in turn.

Switching of triac TRC1, as affected by the HEAT signal is made in synchronization with the zero-cross signal ZCROSS which is generated by the power supply unit. The zero-cross signal detector watches the transition of alternating plus and negative current and detects the zero crosses. This detector derives the resultant ZCROSS signal at its pin #43 of the engine CPU (U01). Since abrupt change in the current flow can be significantly avoided by synchronizing triac TRC1 with the zero-cross signal, the possibility of noise due to the primary AC supply is greatly reduced.

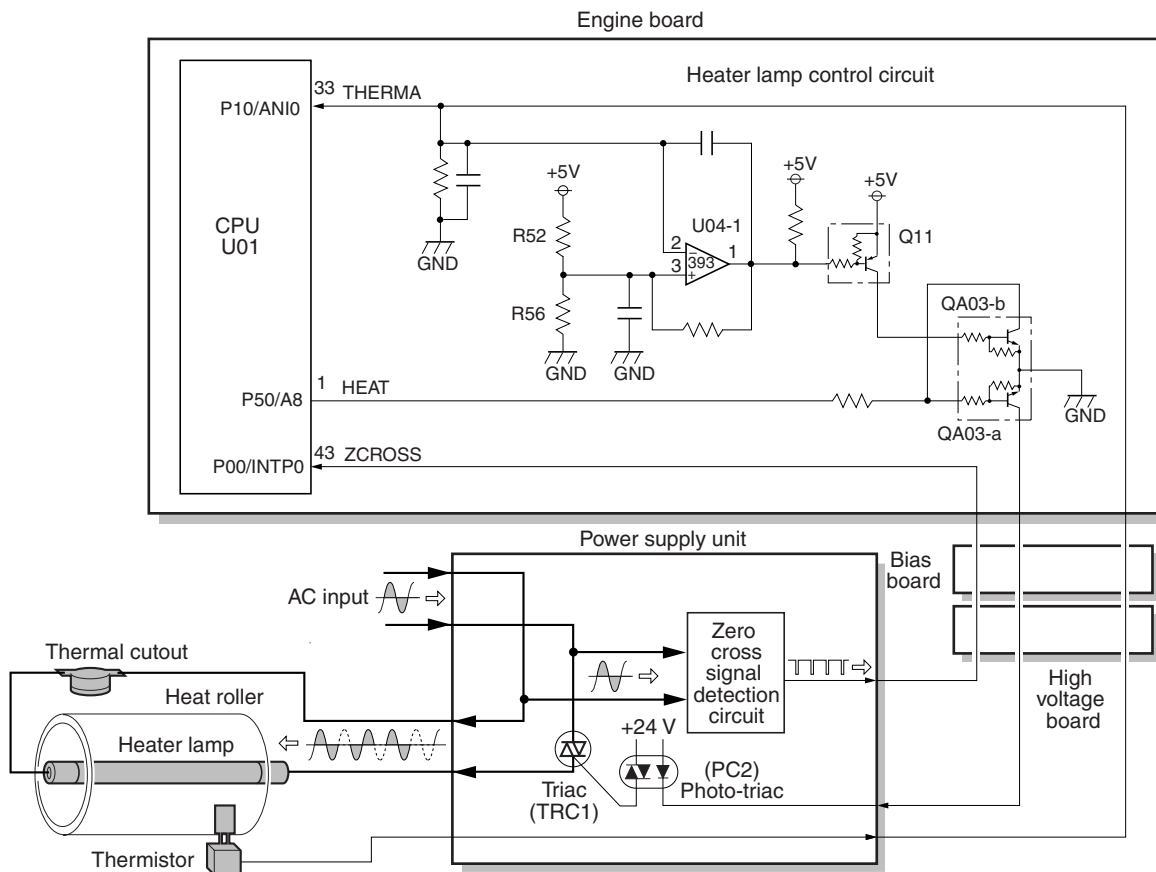
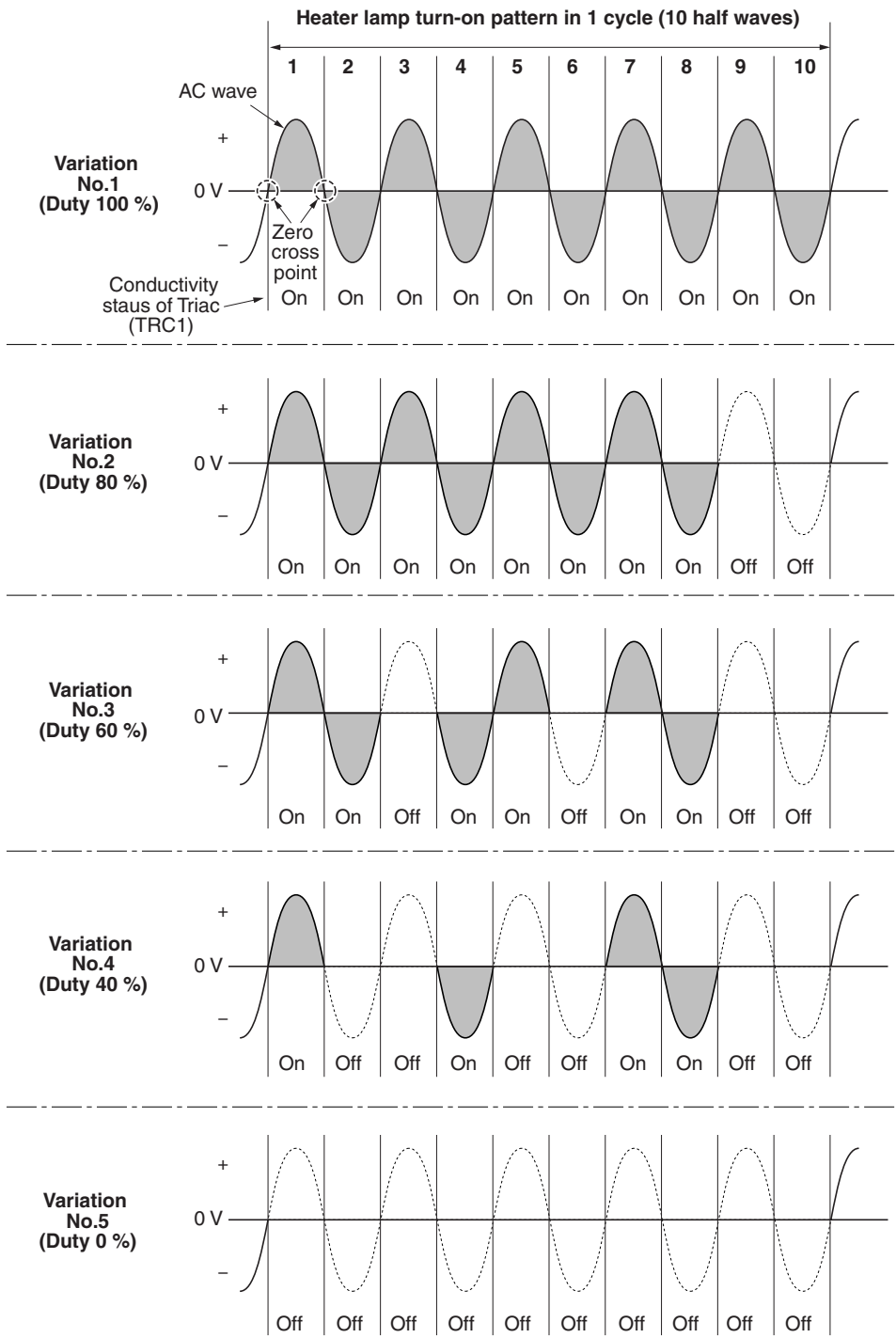

Figure 4-3-5 heater lamp control circuit

The AC power for the heater is applied in one of the five variations of the zero cross switchings as shown in Figure 4-3-6. Each variation is constituted with the unit of ten positive and negative envelopes in five cycles, as obtained by varying the duration during which TRC1 turns on. The heater lamp is energized while TRC1 is kept on; the heater lamp is turned off while TRC1 is kept off. For example, the duty cycle (the period of a cycle during which the heater lamp is turned on) is maximum for variation No.1 as the heater lamp is energized for the whole envelopes. The duty cycle is 60 % for variation No.3 as the heater lamp is energized for the 6 positive and negative envelopes out of 10. The duty cycle is 0 since the heater lamp is kept turned off for the whole envelopes.

CPU (U01) selectively switches among those variations for applying voltages to the heater lamp according to the THERMA signal which appears at pin #33 as feedback.

A fraction of THERMA is applied to pin #2 of comparator U04-1. The comparator maintains comparison of the potential at pin #2 and pin #3 which gives a reference for the possible anomaly in the heater temperature (bred by resistors R52 and R56). Should the voltage at pin #2 exceed that at pin #3, the level at pin #1 becomes low. Since pin #1 is wired to the output line for the HEAT signal, the HEAT signal is enforced to be low regardless the behavior of CPU (U01), thus preventing possible heat overrun. The message "Call service 6110" is then displayed.



**Figure 4-3-6 heater lamp turn-on variations**

## Polygon motor control circuit

The main controller board supplies the 1700.8 Hz clock pulse (PLGCLK) via the engine board to the PLL control IC (IC1) for the polygon motor. To begin printing, the engine CPU U01 turns PLGDR to H level, the PLL control IC (IC1) starts to revolve the polygon motor so that the revolution is 17,008 rpm which depends on the PLGCLK clock pulse. When PLL control IC (IC1) finds that the polygon motor is revolving at the rated speed, turns PLGDRN to L level to acknowledge the engine CPU that the rated speed has been achieved.

On the contrary, if PLGRDYN does not turn to L level within 8 seconds since PLGDRN has been L level, the printer displays “Call service 4000”.

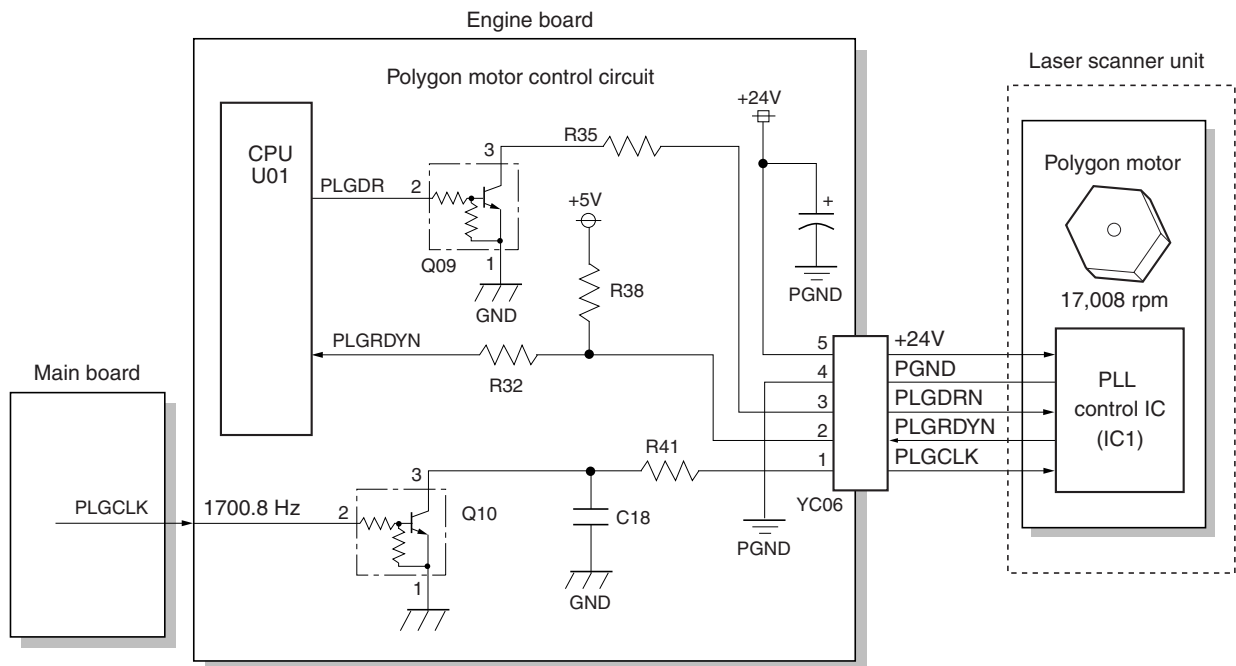

Figure 4-3-7 Polygon motor control circuit

### (3) Power supply board

The power supply board provides the AC power input and DC power and outputs. The high voltage bias generator circuit is mounted on a separate board. A simplified schematic diagram is shown below.

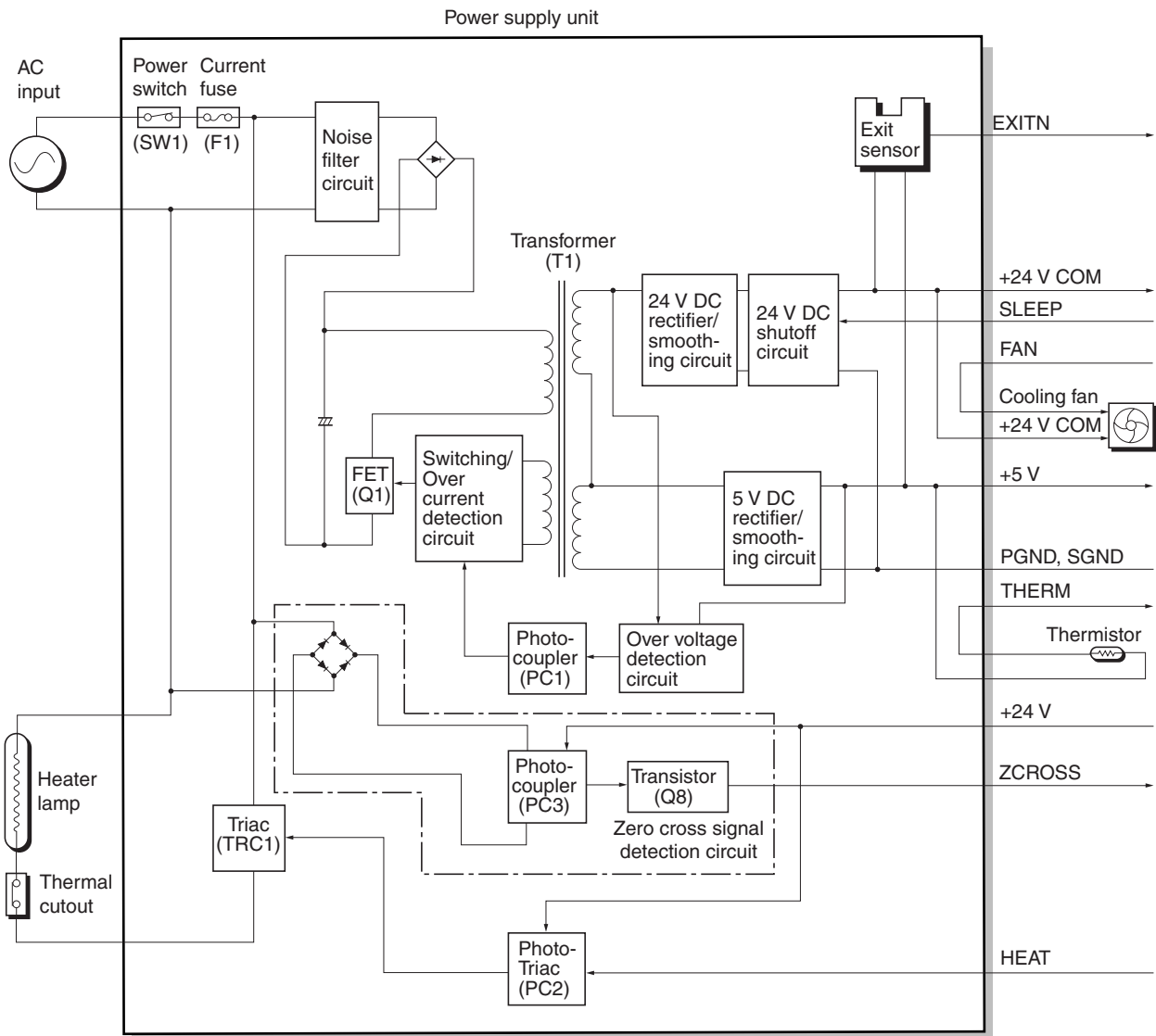

Figure 4-3-8 Power supply board circuit block diagram

#### (4) Bias board

The bias board contains the developing bias output circuit, registration sensor, paper empty sensor, and the cassette switch. It also provides a liaison connection to the high voltage board, power supply, and the toner sensor.

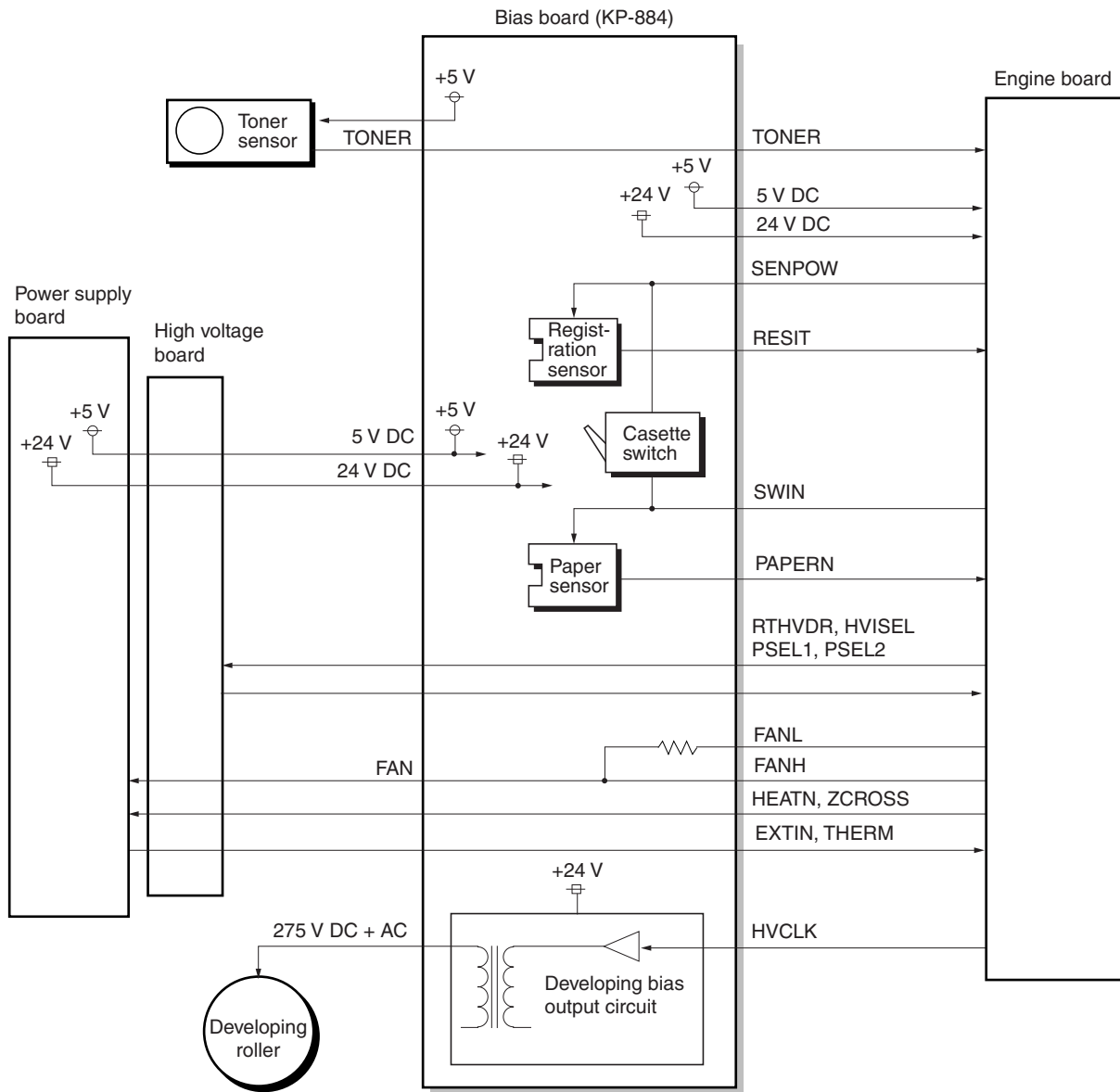

Figure 4-3-9 Bias board circuit block diagram

### (5) High voltage board

The high voltage board contains the high voltage output circuit, interlock switch circuit as well as providing a liaison connection with the power supply board, bias board, and the engine board.

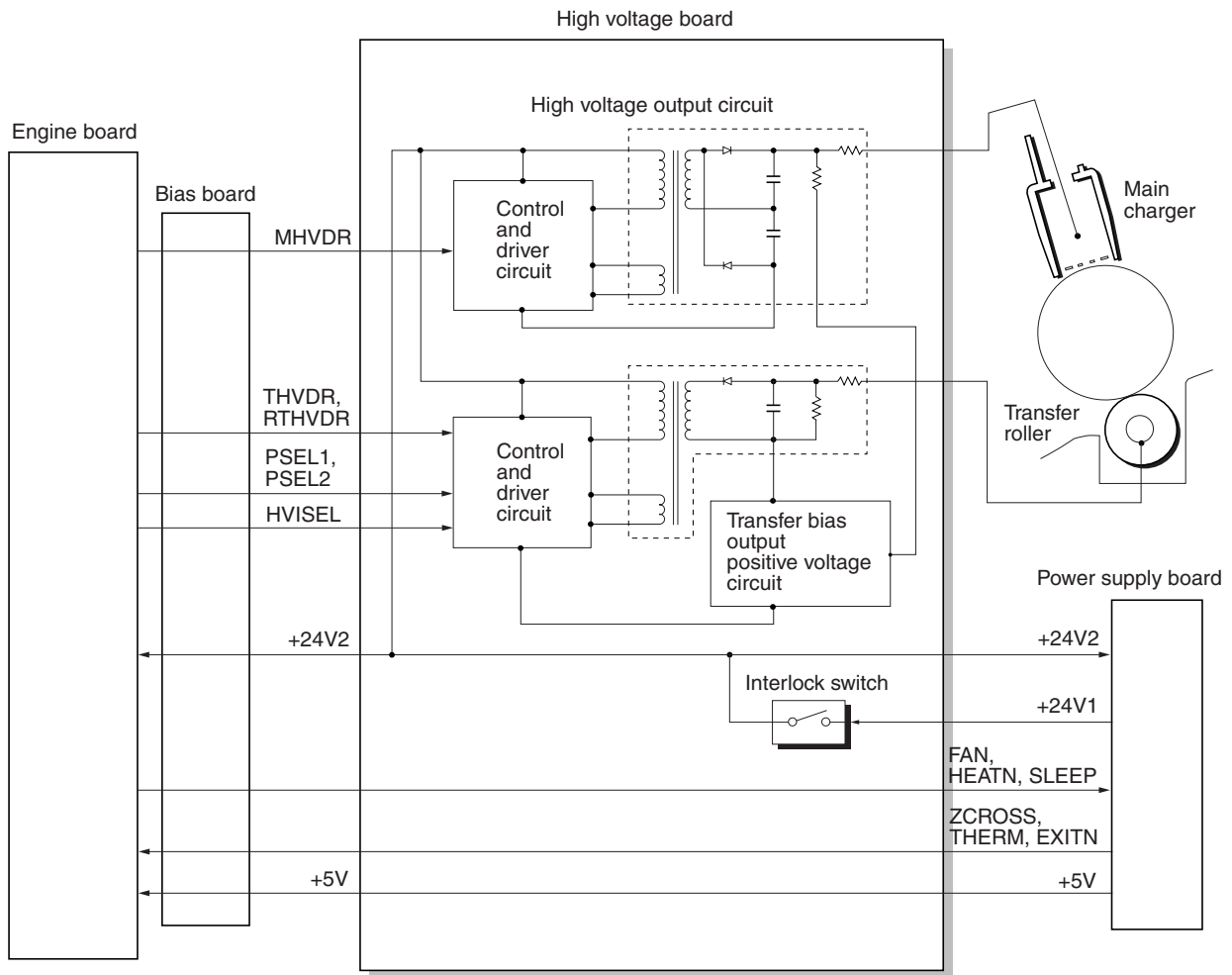
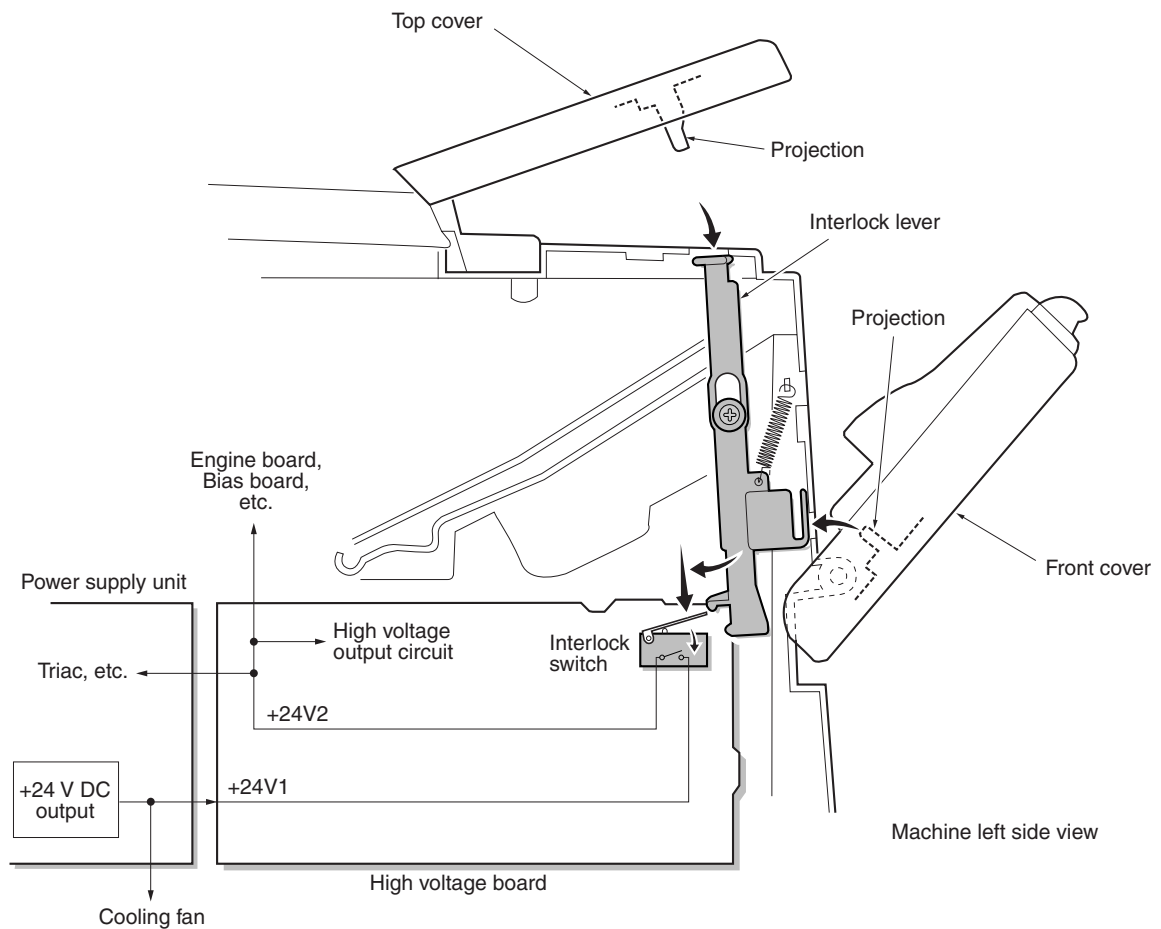

Figure 4-3-10 High voltage board circuit block diagram

## Interlock switch

The interlock switch is located on the high voltage board and opened and closed in conjunction with the front cover or the top cover via the interlock lever. This switch connects and disconnects the +24 V DC power supply line. If the front cover or the top cover is open, the interlock switch is open, and the +24 V DC to the high voltage output circuit, bias board, engine board, and the power supply board is disconnected, deactivating the high voltage output, laser output, main motor output for safety. The cooling fan is an exception: Since the cooling fan is directly fed with +24 V DC from the power supply unit at the primary side (+24V1) of the interlock switch, the cooling fan is not deactivated even the cover is open.



**Figure 4-3-11 Interlock switch**



# Chapter 5    D i s a s s e m b l y

## Chapter 5 Contents

<b>5-1 General instructions .....</b>	<b>5-3</b>
5-1-1 Screw/hardware .....	5-3
5-1-2 Before starting disassembly .....	5-3
<b>5-2 Disassembly .....</b>	<b>5-4</b>
5-2-1 Removing the process unit .....	5-4
5-2-2 Removing the principal outer covers .....	5-5
(1) Removing the top cover/face-down output tray .....	5-5
(2) Removing the right cover .....	5-6
(3) Removing the left cover .....	5-6
5-2-3 Removing the feed roller .....	5-7
5-2-4 Removing the MP tray feed roller .....	5-8
5-2-5 Removing the transfer roller .....	5-10
5-2-6 Removing the principal circuit boards .....	5-11
(1) Removing the engine board .....	5-11
(2) Removing the main board .....	5-12
(3) Removing the power supply board and high voltage board .....	5-14
(4) Removing the bias board .....	5-15
5-2-7 Removing the main motor and drive unit .....	5-16
5-2-8 Removing and splitting the fuser unit .....	5-20
(1) Removing the separators .....	5-22
(2) Removing the heater lamp .....	5-23
(3) Removing the heat roller .....	5-24
(4) Removing the thermistor .....	5-26
(5) Removing the thermal cutout .....	5-27
(6) Removing the press roller .....	5-28
5-2-9 Removing the laser scanner unit and the eraser lamp .....	5-29
5-2-10 Removing the main charger unit .....	5-32

## 5-1 General instructions

This chapter provides procedures for removal and replacement of the field replacement components. For other components not explained in this chapter, the diagrams in the *Parts Catalog* attached with this manual will help locate the component.

When replacing of a component, reverse the procedure for the removal procedure explained in this chapter.

### **WARNING**



To avoid injury to human bodies, make sure that AC power is removed and the power cord is unplugged from both the power line and the printer.

### **5-1-1 Screw/hardware**

Screws and hardware used in the printer are listed in the *Ecosys Screw catalog*. These screw symbol numbers are universal to most Ecosys printers.

### **CAUTION**



When securing a self-tapping screws, align it with the thread carefully. First turn it counterclockwise, then slowly clockwise. Do not overtighten. In case the self-tapped thread is damaged, the affected part must be replaced with a new part.

### **5-1-2 Before starting disassembly**

Before proceeding, unplug the power cord from the printer and the power supply.

### **WARNING**



Never attempt to operate the printer with a component removed.

### **CAUTION**



The printer use electrostatic sensitive parts inside (on circuit boards, Laser scanner unit, etc.). Provide an antistatic (discharging) device, such as a wrist strap, that can effectively discharge your body before touching the circuit boards, the laser scanner unit, etc.

## 5-2 Disassembly

Before proceeding, remove the paper cassette and the optional paper feeder, if installed.

### 5-2-1 Removing the process unit

1. Open the top cover ①.
2. Open the front cover ②.
3. Lift the process unit ③ together with the toner container out of the printer.

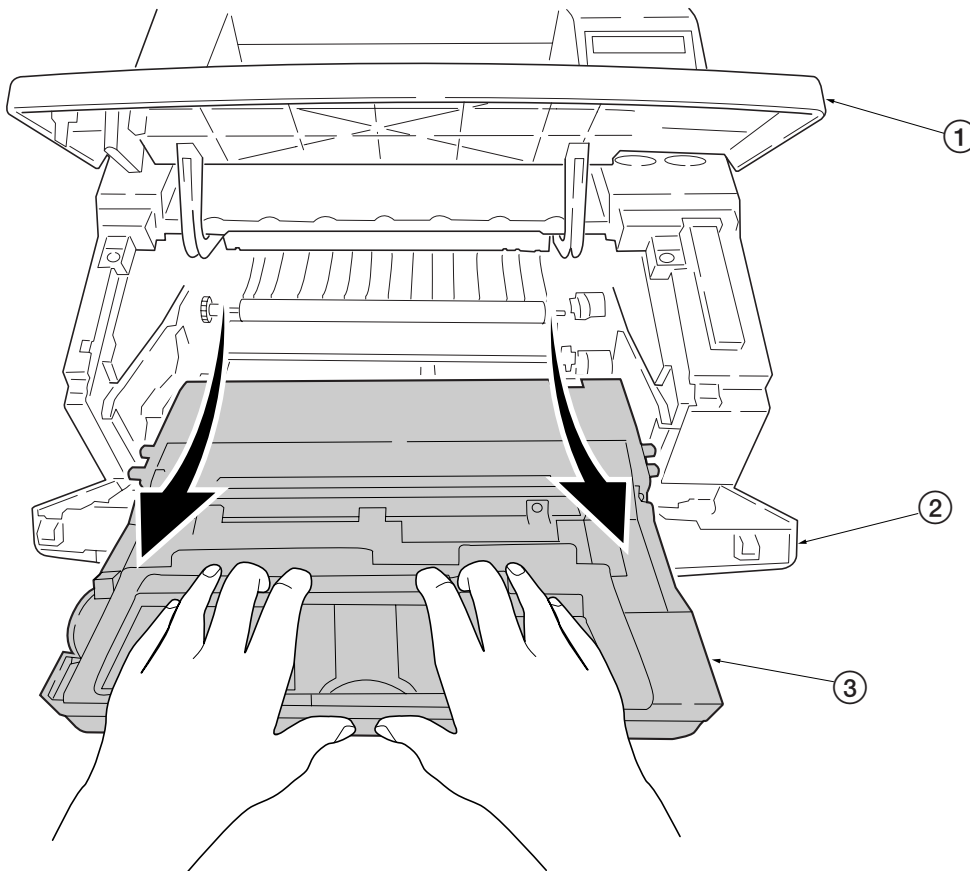

**Figure 5-2-1 Removing the process unit**

#### CAUTIONS



After removing the process unit, seal it in the protective bag and place it on flat surface. Do not place the process unit in a dusty area.

Do not give impact to the process unit.

Do not place floppy disks near the process unit.

## 5-2-2 Removing the principal outer covers

### (1) Removing the top cover/face-down output tray

1. Open the top cover ①.
2. Remove two screws ②.
3. Remove one connector ③.
4. Remove the top cover/face-down output tray ④.

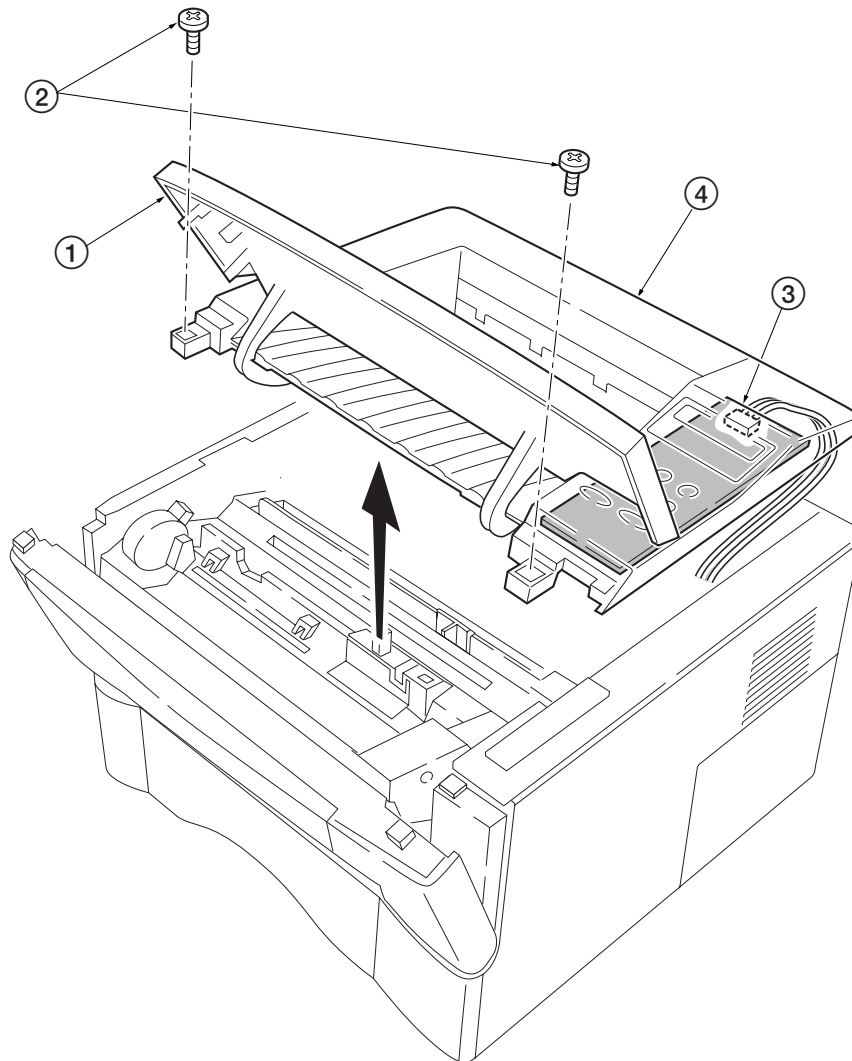

Figure 5-2-2 Removing the top cover/face-down output tray

## (2) Removing the right cover

1. Remove one screw (1).
2. Remove the side cover (2).
2. Unlatch the six snaps (3) and one hook hole (4) on the chassis, remove the right cover (5).

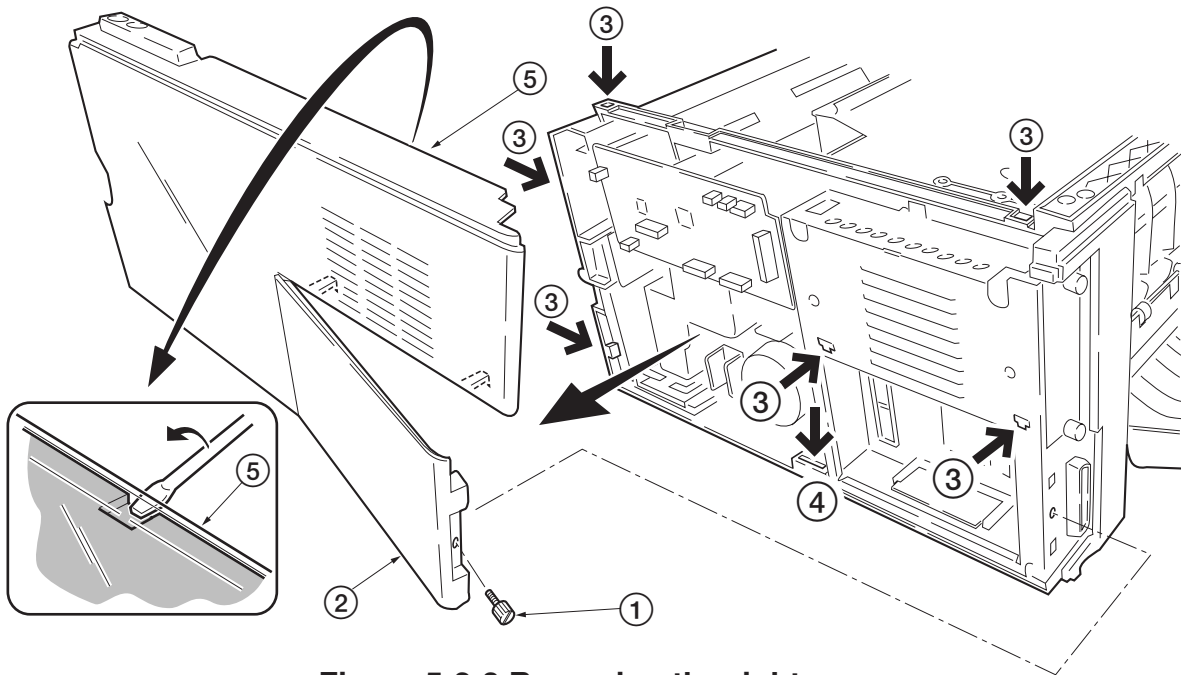

Figure 5-2-3 Removing the right cover

## (3) Removing the left cover

1. Unlatch the six snaps (1) and two hook holes (2) on the chassis, remove the left cover (3).

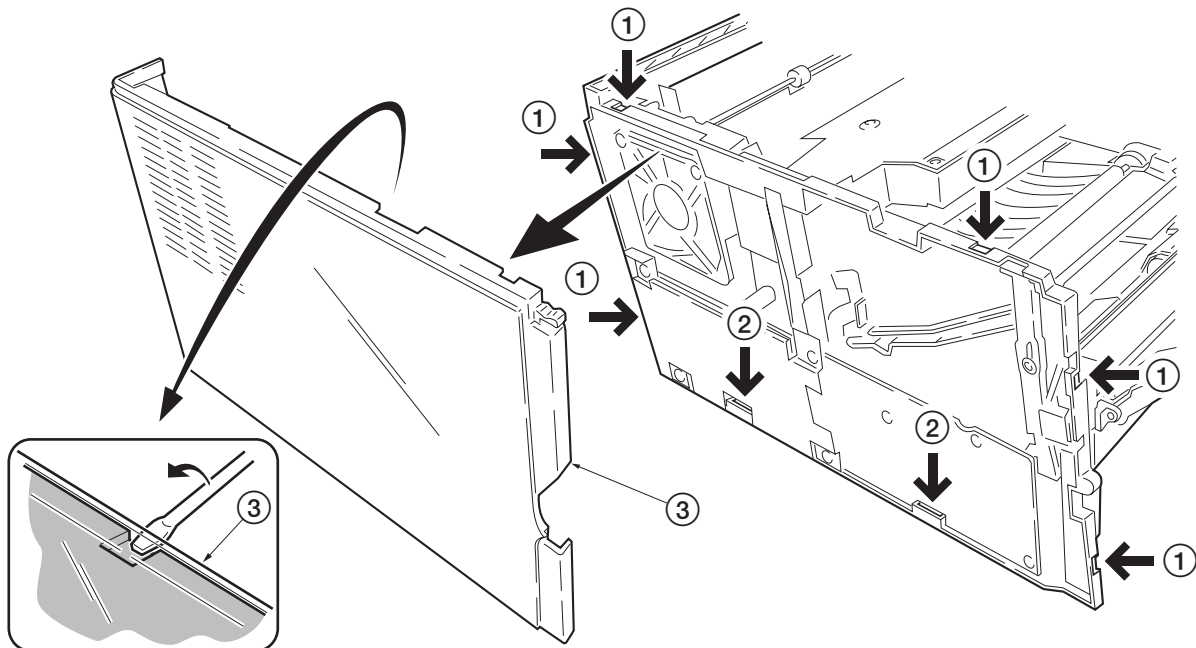

Figure 5-2-4 Removing the left cover

### 5-2-3 Removing the feed roller

#### CAUTION

When refit the feed roller, fit the D-cut shaft into the D-shape hole of the feed roller.



1. Remove the paper cassette and the process unit. (See page 5-4)
2. Stand the machine the front side up.
3. Move the feed roller in the direction (A), and remove the feed roller (1).

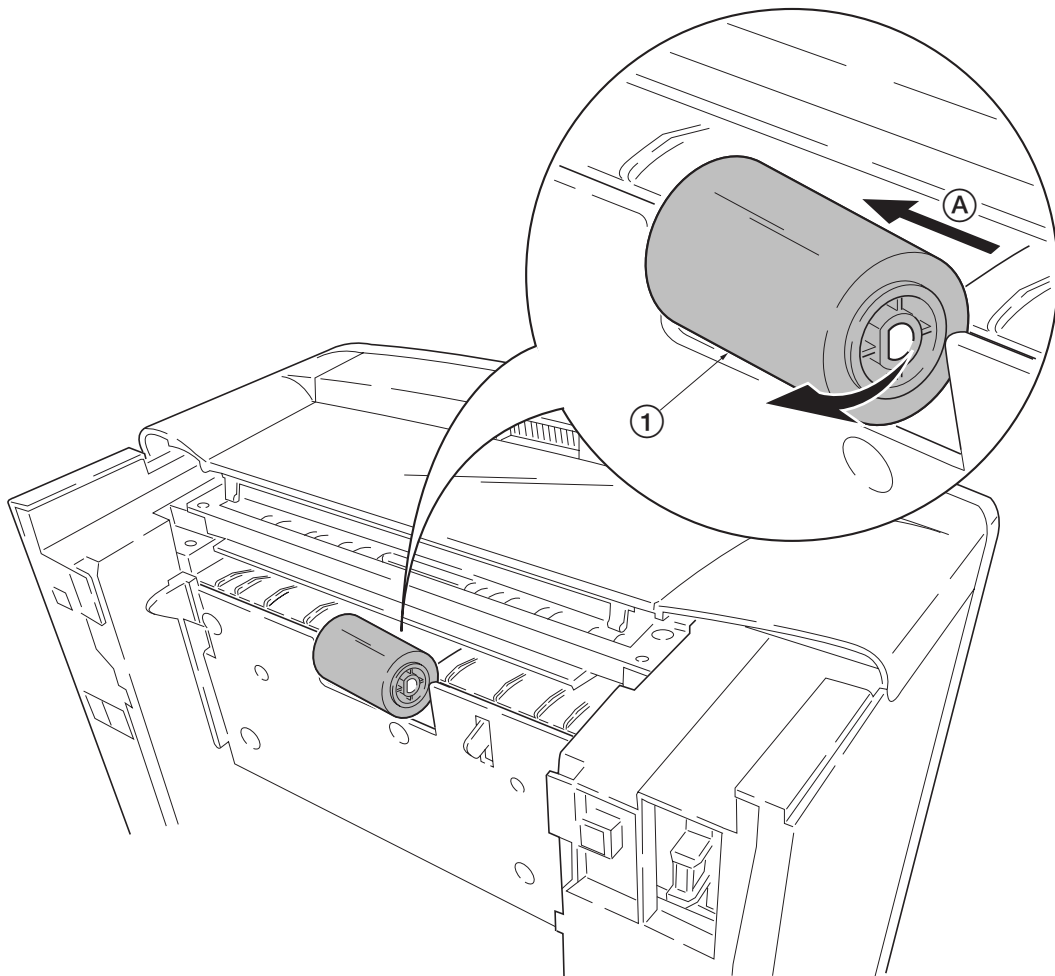

Figure 5-2-5 Removing the feed roller

### 5-2-4 Removing the MP tray feed roller

1. Remove the engine board. (See page 5-11)
2. Remove one screw ①.
3. Remove the grounding plate ②.
4. Remove one stop ring ③.
5. Remove the MP feed clutch ④.

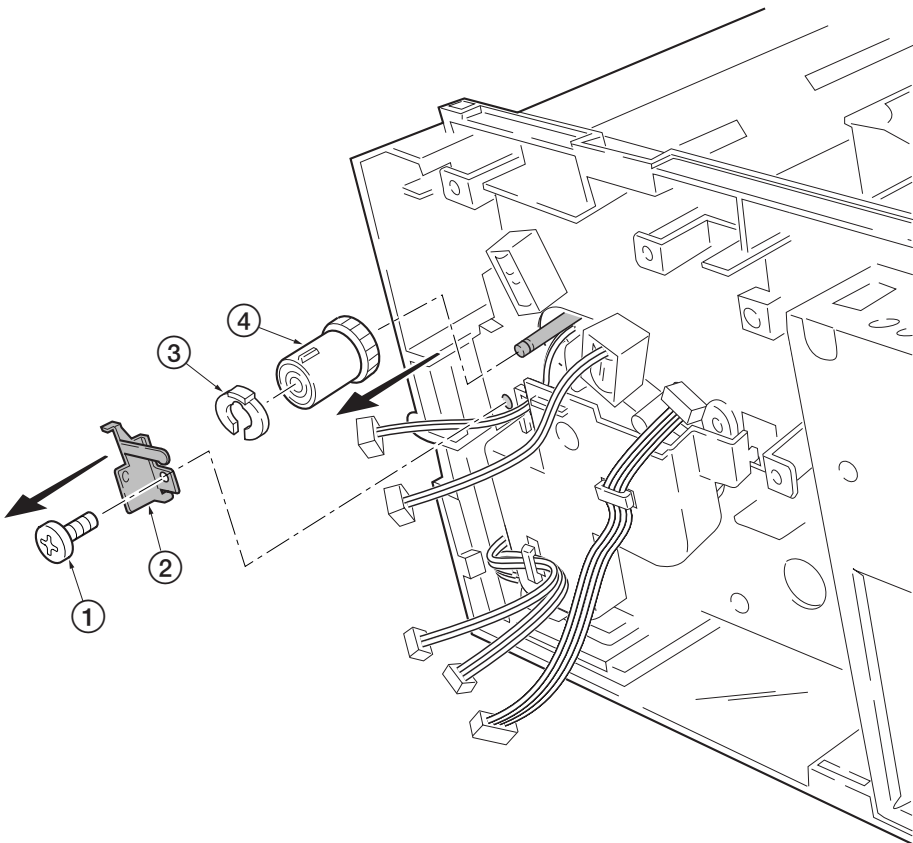
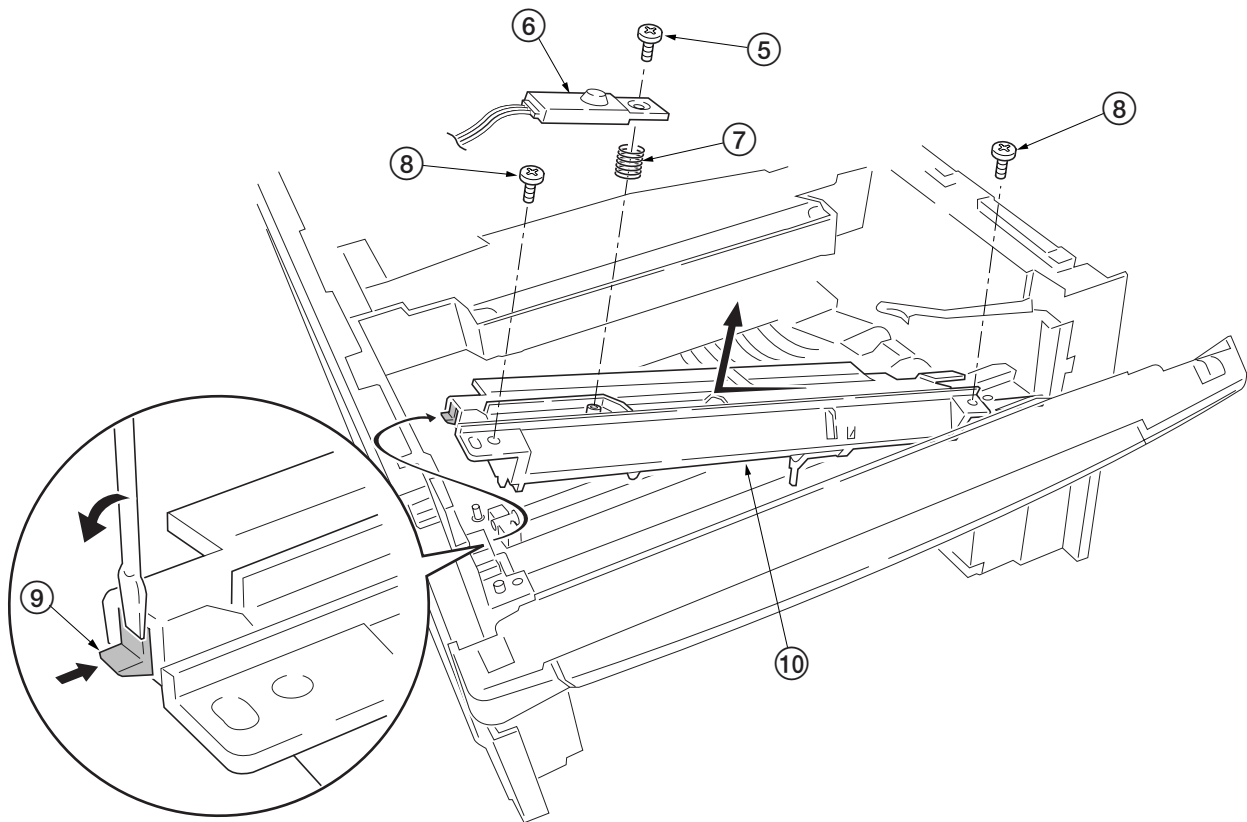

Figure 5-2-6 Removing the MP feed clutch



6. Remove one screw (5).
7. Remove the toner sensor (6) and spring (7).
8. Remove two screws (8).
9. While pressing the latch (9) by using the driver and then remove the MP feed unit (10).



**Figure 5-2-7 Removing the MP feed unit**

10. Remove the stop ring (11) and then remove the MP feed roller (12).

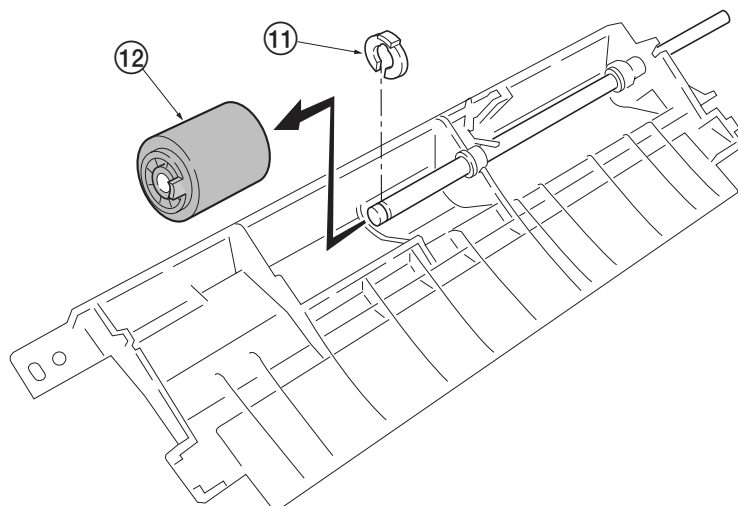

**Figure 5-2-8 Removing the MP feed roller**

## 5-2-5 Removing the transfer roller

### CAUTION



Do not touch the transfer roller (sponge) surface. Oil and dust (particles of paper, etc.) on the transfer roller can significantly deteriorate the print quality (white spots, etc.).

When refitting the bushes and springs, make sure to refit the black colored bush and spring on the left side. Also, observe the correct direction to which the bush is fit in reference to the paper passing direction.

1. Remove the process unit. (See page 5-4)
2. Remove the transfer roller ① from the both bushes.

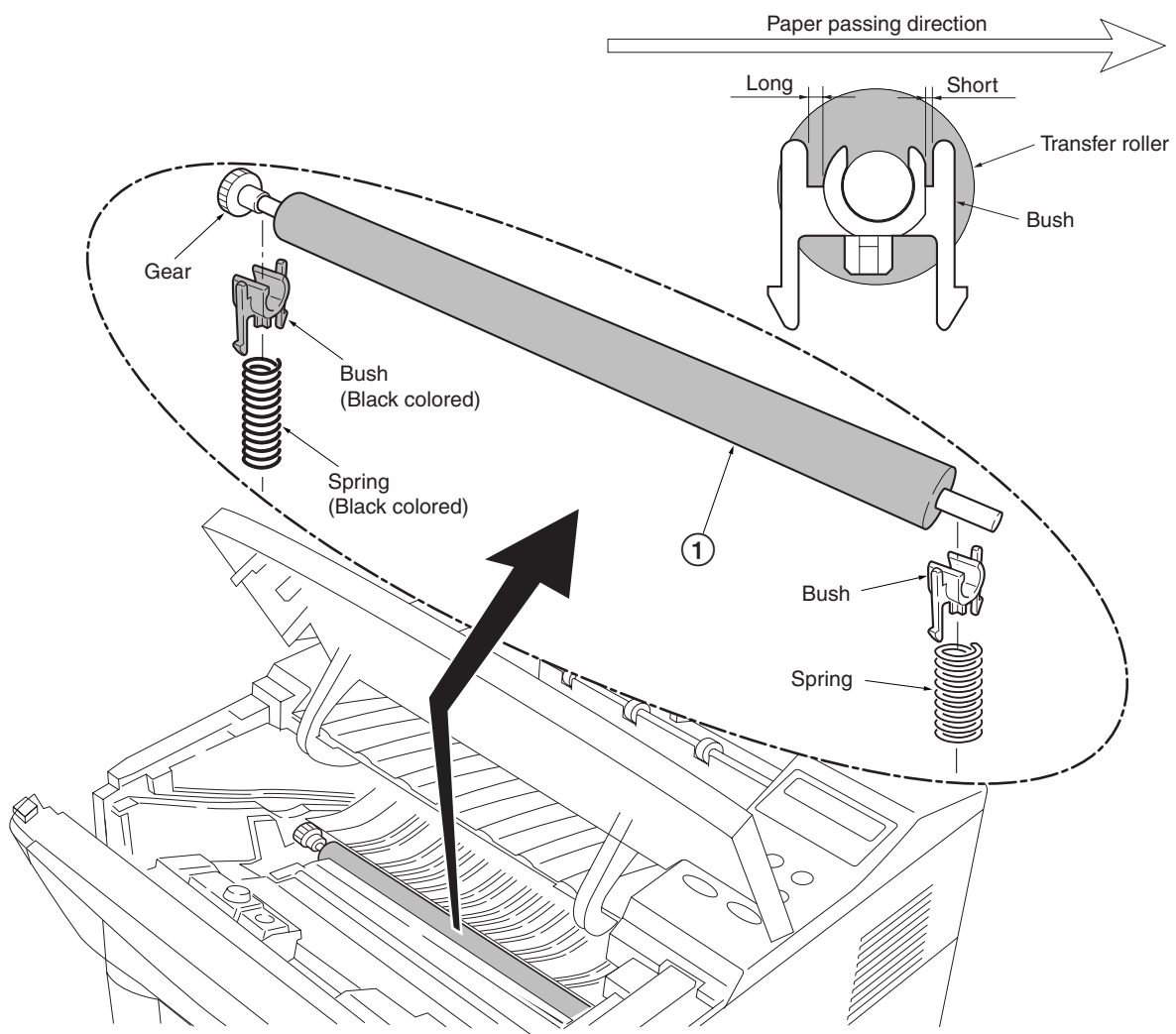

**Figure 5-2-9 Removing the transfer roller**

## 5-2-6 Removing the principal circuit boards

### (1) Removing the engine board

1. Remove the top cover/face-down output tray and right cover (See pages 5-5 and 5-6).
2. Remove all (ten) connectors from the engine board ①.
3. Remove three screws ②.
4. Remove the engine board ①.

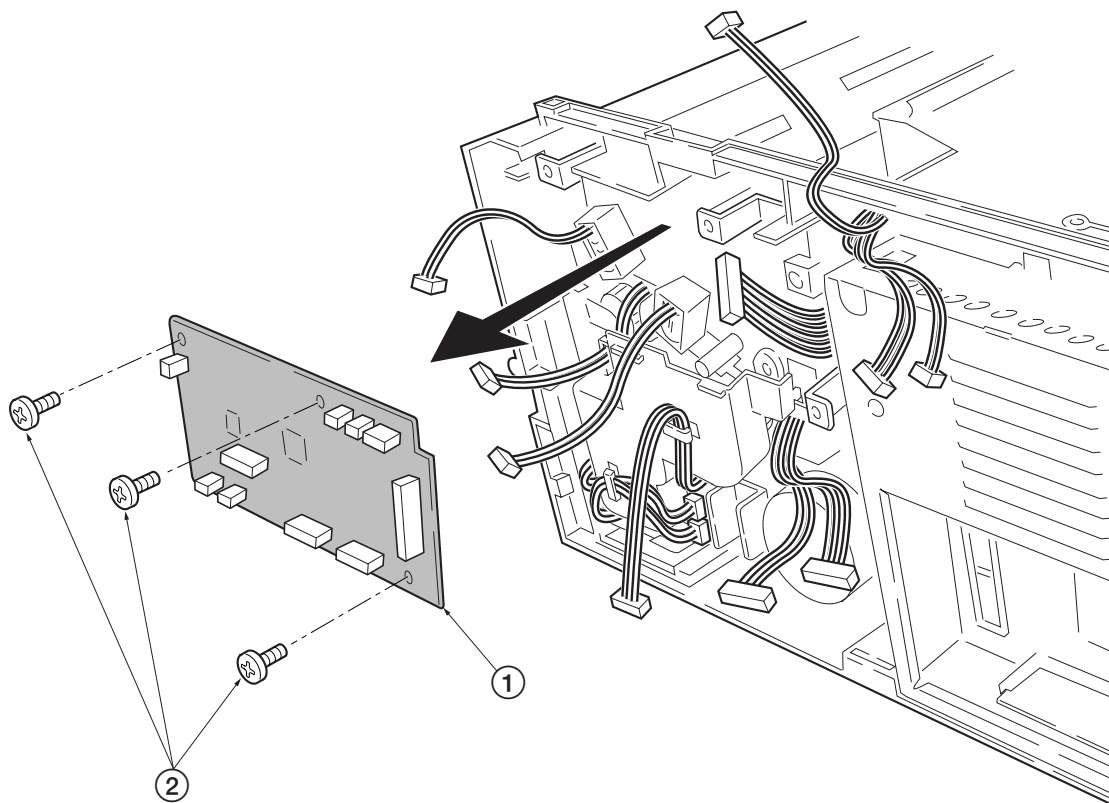

Figure 5-2-10 Removing the engine board

## (2) Removing the main board

1. Remove the process unit (See page 5-4).
2. Remove the top/face-down output tray and right cover (See pages 5-4 and 5-5).
3. Remove two connectors ① from main board ②.
4. Remove six screws ③.
5. Remove the controller box (with main board) ④.

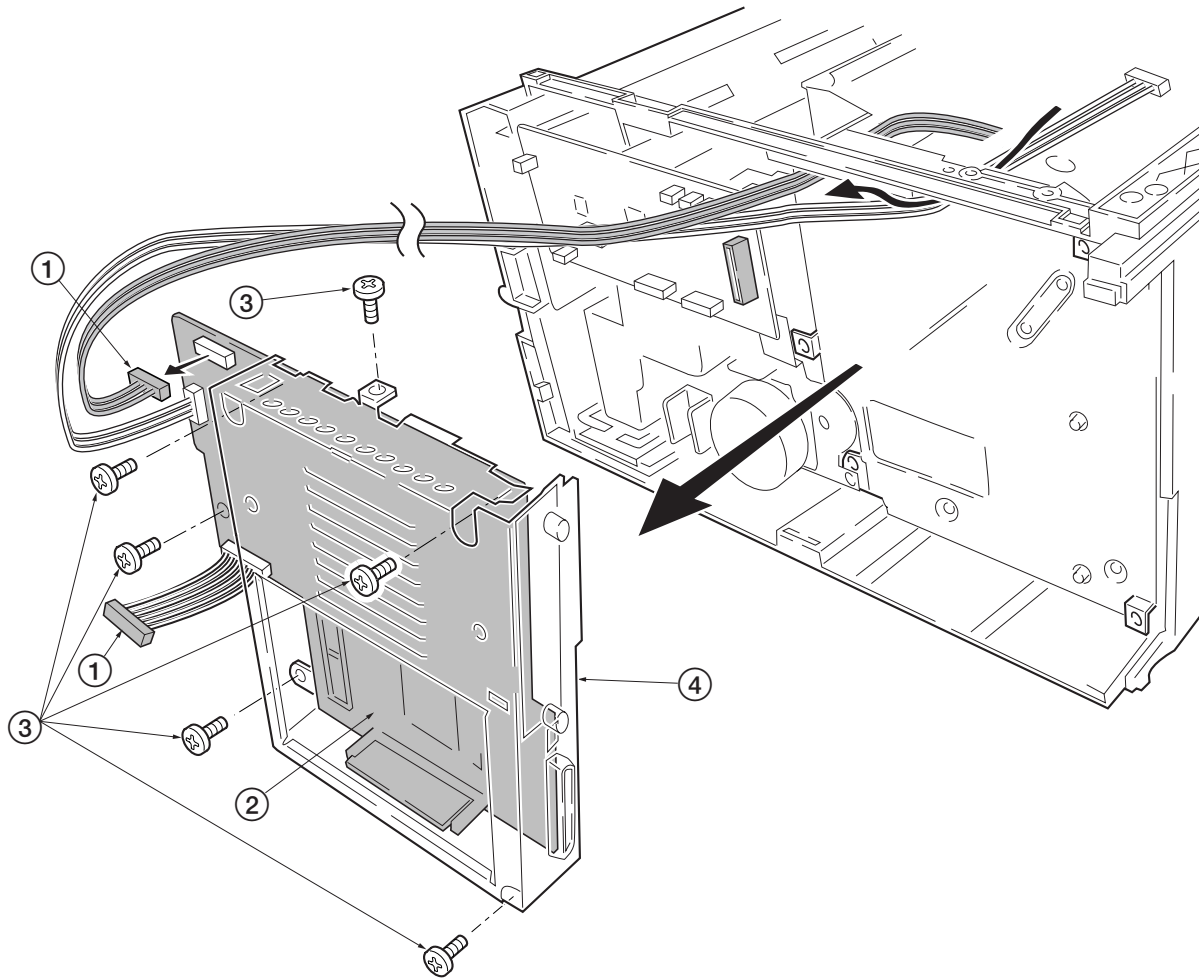
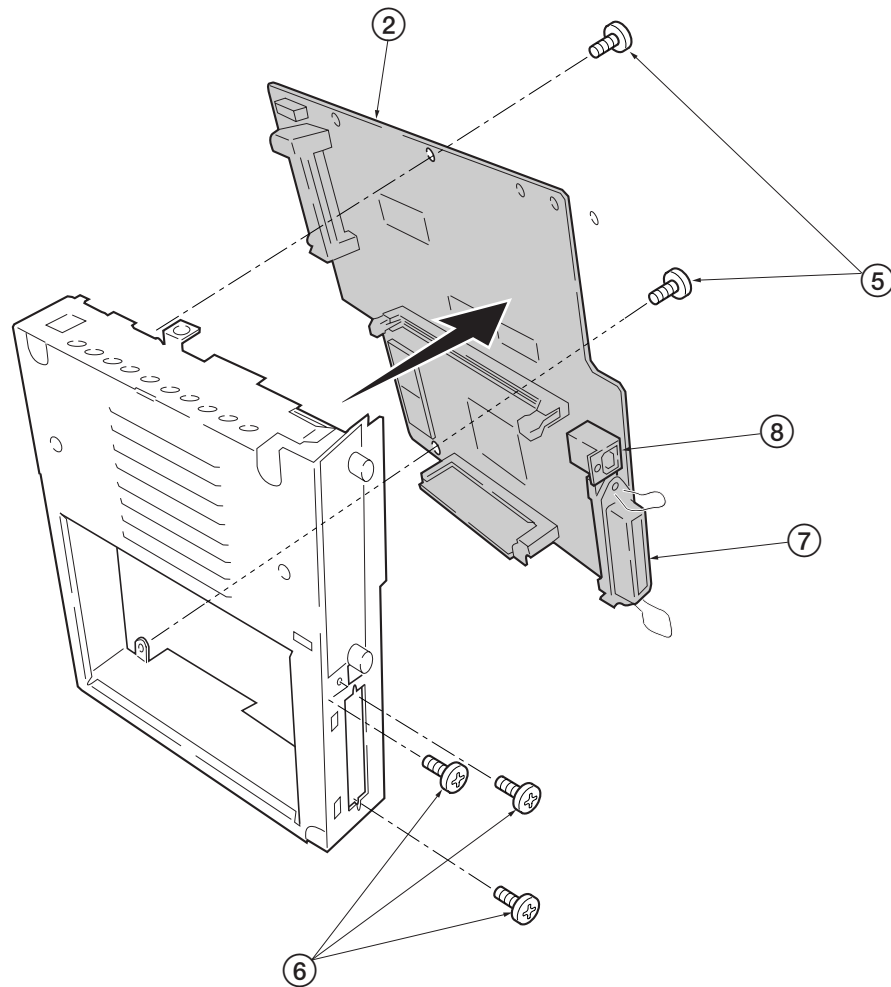

Figure 5-2-11 Removing the controller box (with main board)

6. Remove two screws (5) at the back of the main board (2).
7. Remove three screws (6) from the parallel interface connector (7) and USB connector (8).
8. Remove the main board (2).



**Figure 5-2-12 Removing the main board**

### (3) Removing the power supply board and high voltage board

1. Remove the process unit (See page 5-4).
2. Remove the top cover/face-down output tray and left cover (See pages 5-5 and 5-6).
3. Remove three connectors ① from the power supply board ②.
4. Remove eight screws ③.
5. Remove the power supply board ② and high voltage board ④. (Note: The high voltage board ④ is directly connected to the bias board ⑤.)
6. Separate the high voltage board ④ from the power supply board ②.

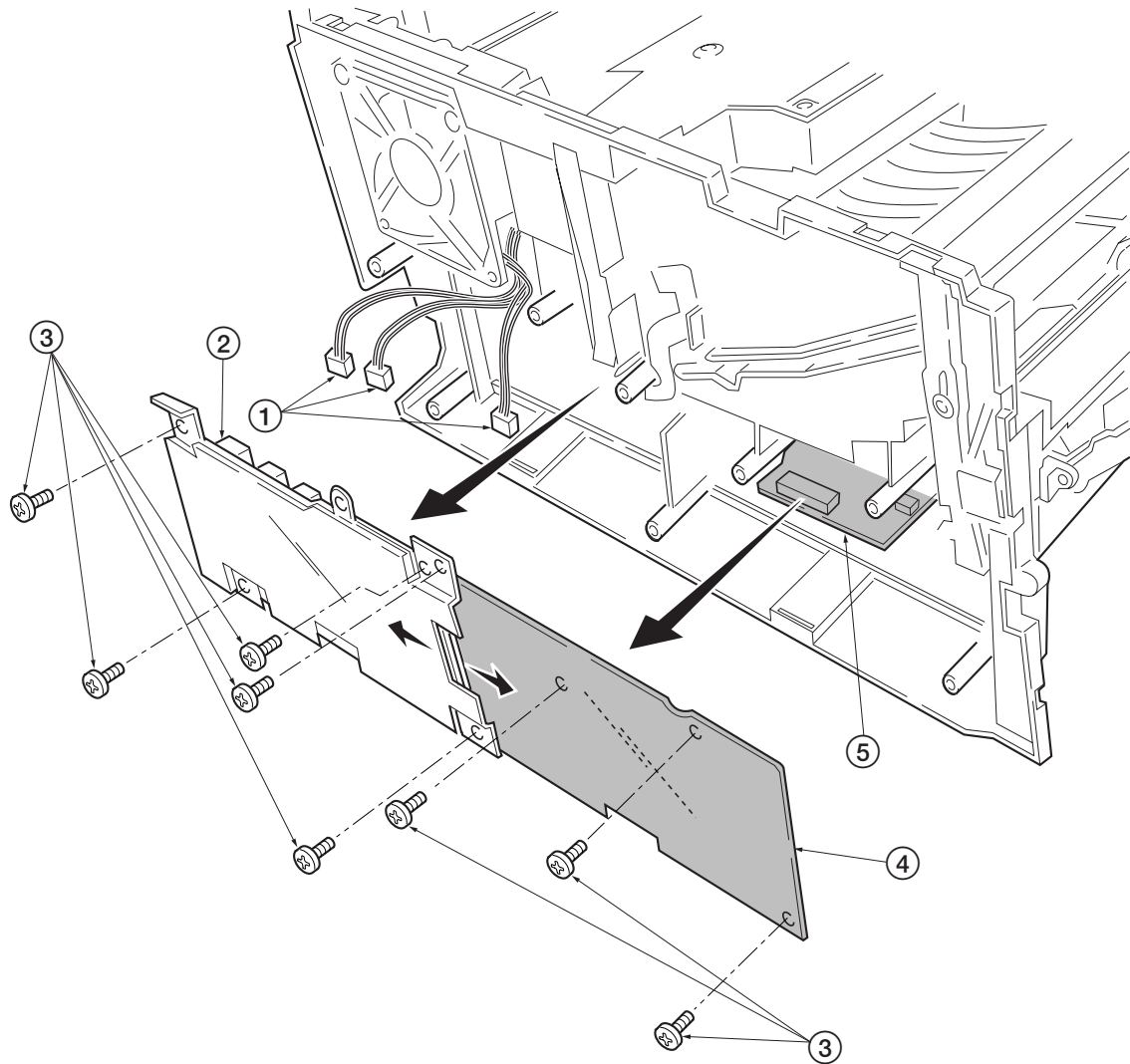

Figure 5-2-13 Removing the power supply board and high voltage board

#### (4) Removing the bias board

1. Remove the cassette and process unit (See page 5-4).
2. Remove the top cover/face-down output tray and left cover (See pages 5-5 and 5-6).
3. Remove the power supply board and high voltage board (See the previous page).
4. Stand the machine with the front side up.
5. Remove one connector ① from the bias board ②.
6. Remove five screws ③.
7. Remove the bottom cover ④.
8. Remove the two connectors ⑤ from the bias board ②.
9. Remove the bias board ②.

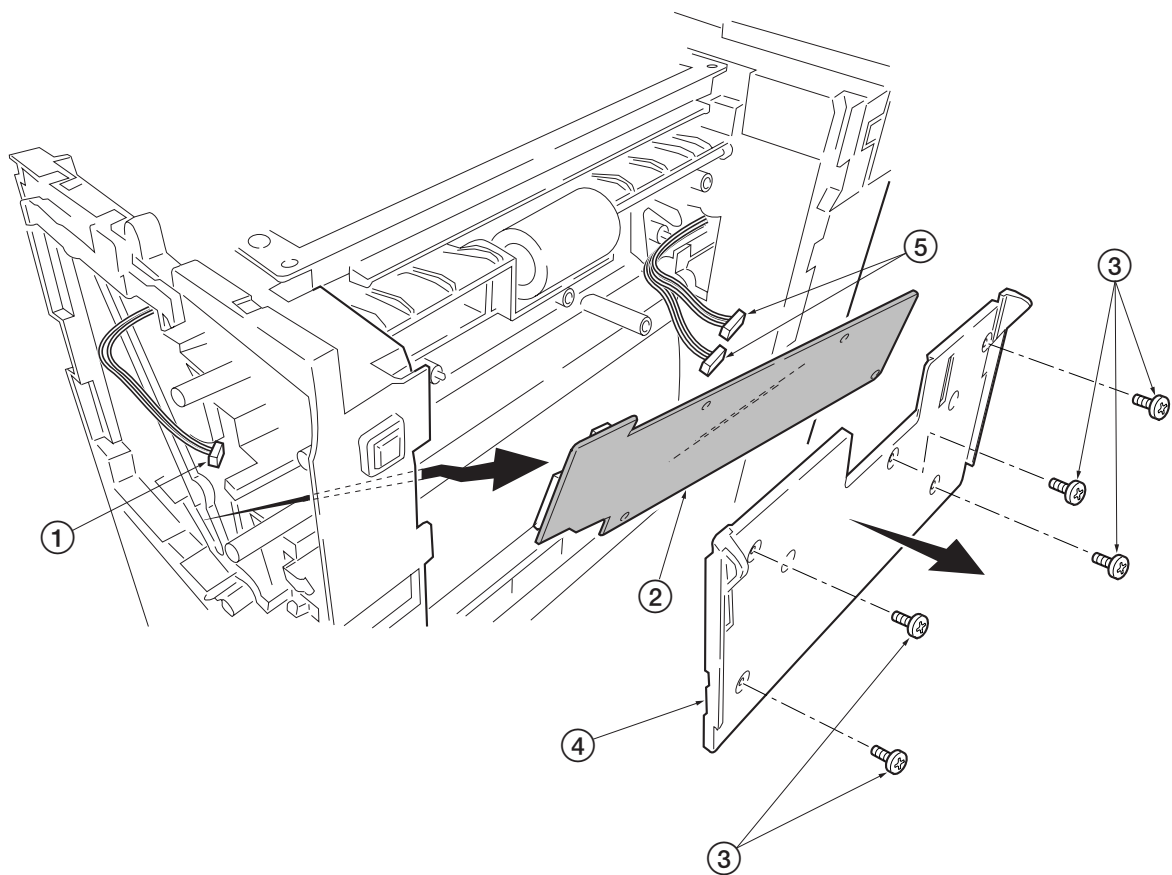

Figure 5-2-14 Removing the bias board

### 5-2-7 Removing the main motor and drive unit

1. Remove the cassette and process unit (See page 5-4).
2. Remove the top cover/face-down output tray and right cover (See pages 5-5 and 5-6).
3. Remove three connectors ① from the main motor ②.
4. Remove four screws ③.
5. Remove main motor ②.

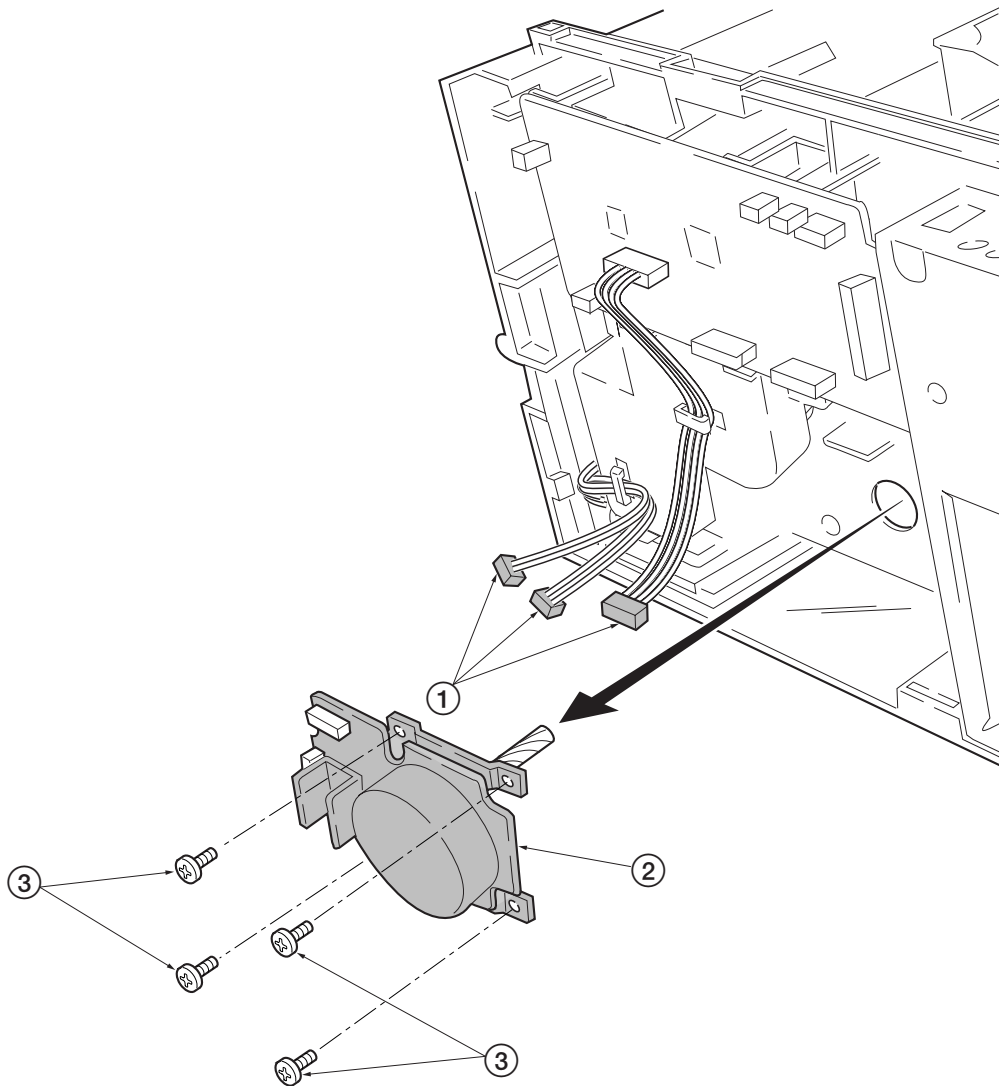
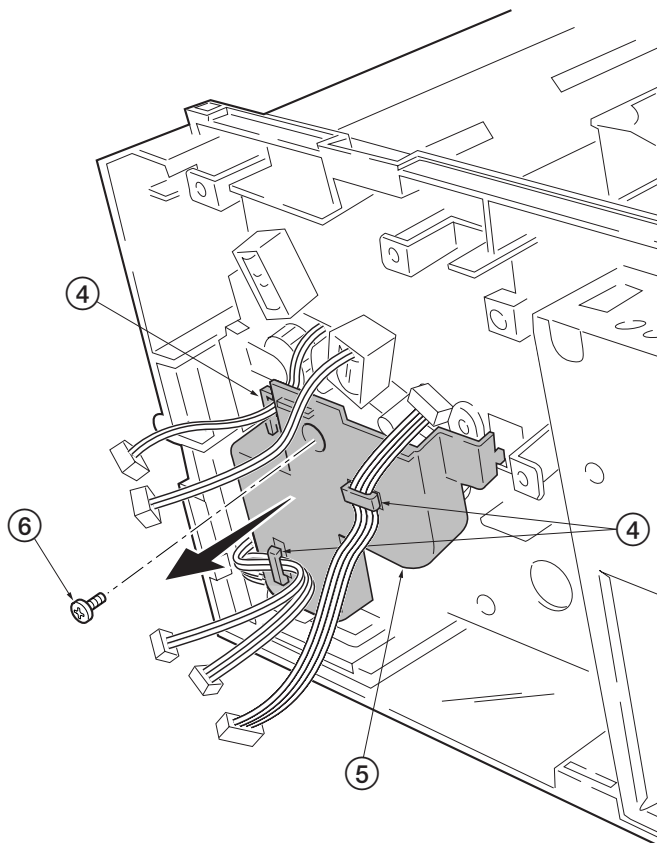

Figure 5-2-15 Removing the main motor



6. Remove the engine board (See page 5-11).
7. Remove wires from wire saddles (4) on the cord cover (5).
8. Remove one screw (6).
9. Remove the cord cover (5).



**5-2-16 Removing the cord cover**

10. Remove one screw (6).
11. Remove the grounding plate (7).
12. Remove three stop rings (8).
13. Remove MP feed clutch (9), feed clutch (10), and registration clutch (11).

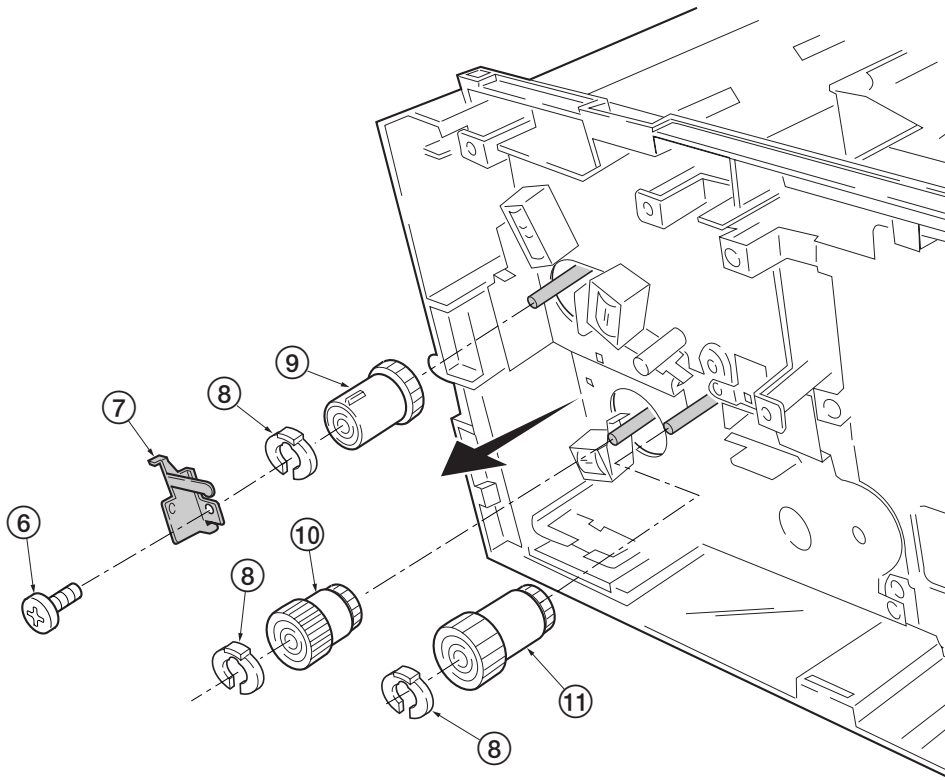

**Figure 5-2-17 Removing the clutches**

14. Remove the four screws ⑫.

15. Remove the drive unit ⑬.

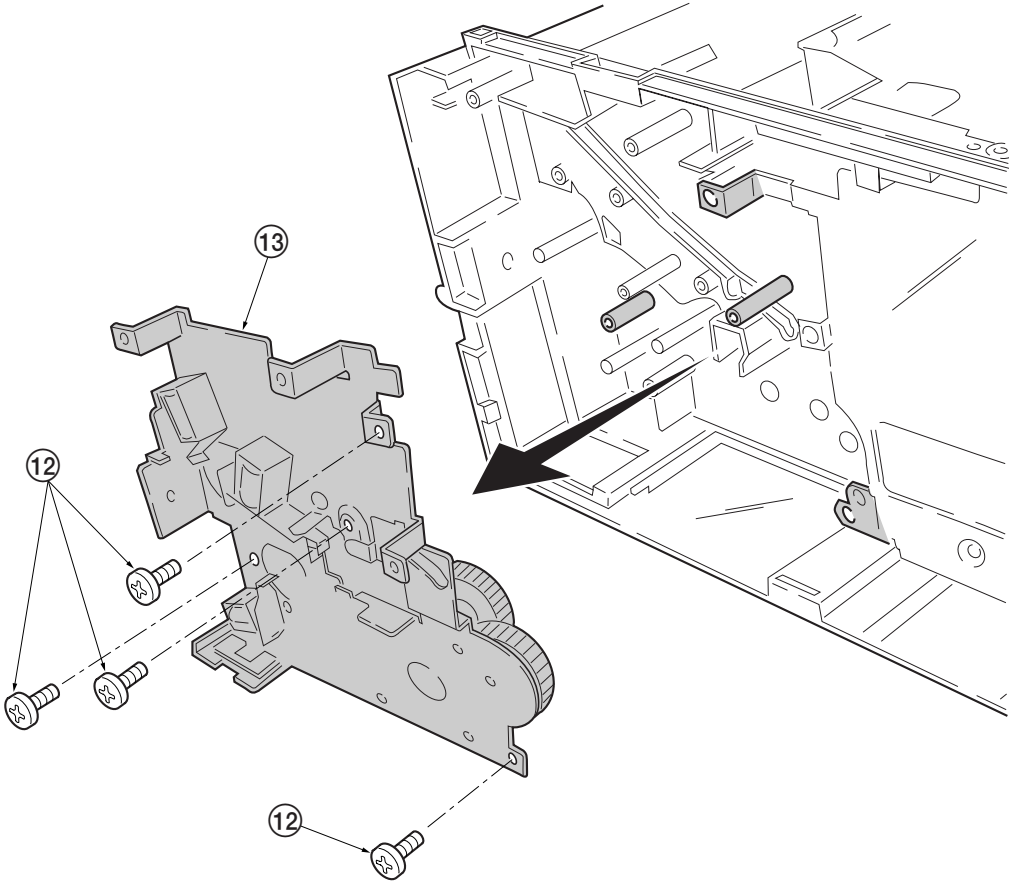

**Figure 5-2-18 Removing the drive unit**

## 5-2-8 Removing and splitting the fuser unit

**WARNING** The fuser unit is hot after the printer was running. Wait until it cools down.



**CAUTION** When refitting the fuser unit, make sure the fuser unit gear and the printer's drive gear are properly meshed with each other. For this, rotate the main motor several turns before fixing screws.



1. Remove the process unit. (See page 5-4)
2. Remove the top cover/face-down output tray, right and left covers. (See page 5-5, 5-6)
3. Remove the rear side cover (1).
4. Remove the two connectors (2).
5. Remove two screws (3).
6. Remove the fuser unit (4).

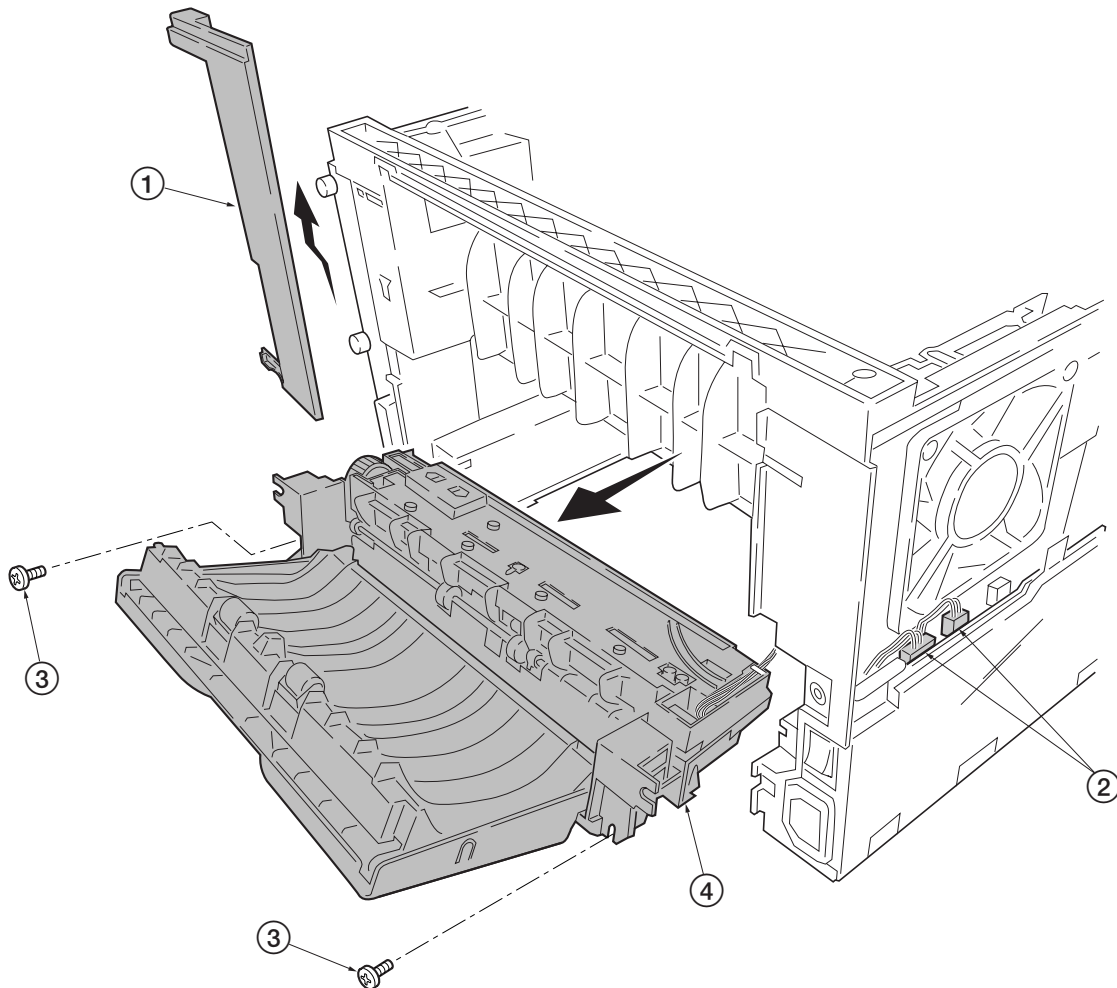

**Figure 5-2-19 Removing the fuser unit**

7. Remove two screws (5).
8. Open and split the fuser unit (4).

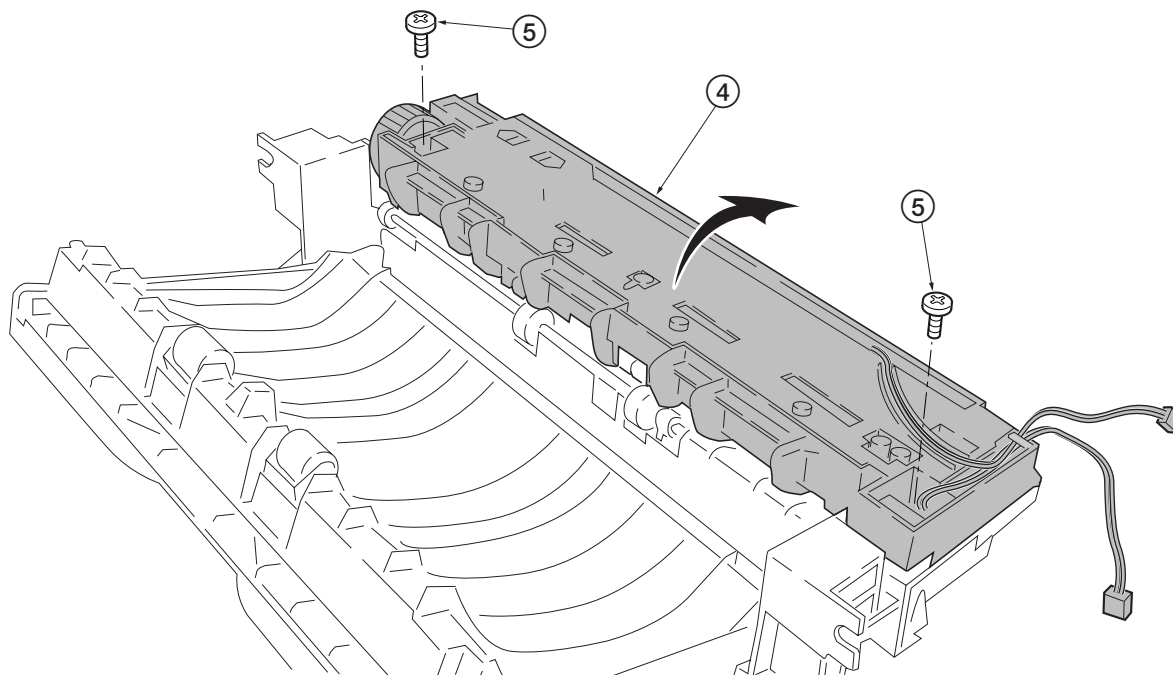

**Figure 5-2-20 Splitting the fuser unit**

## (1) Removing the separators

**WARNING** The separation claws are extremely hot immediately after the printer was running. Allow substantial period of time until it cools down.



1. Remove and split the fuser unit (See page 5-20).
2. Loosen the stopper screws ①.
3. Hold the separators ② upright, and remove the separators ② and separator springs ③.

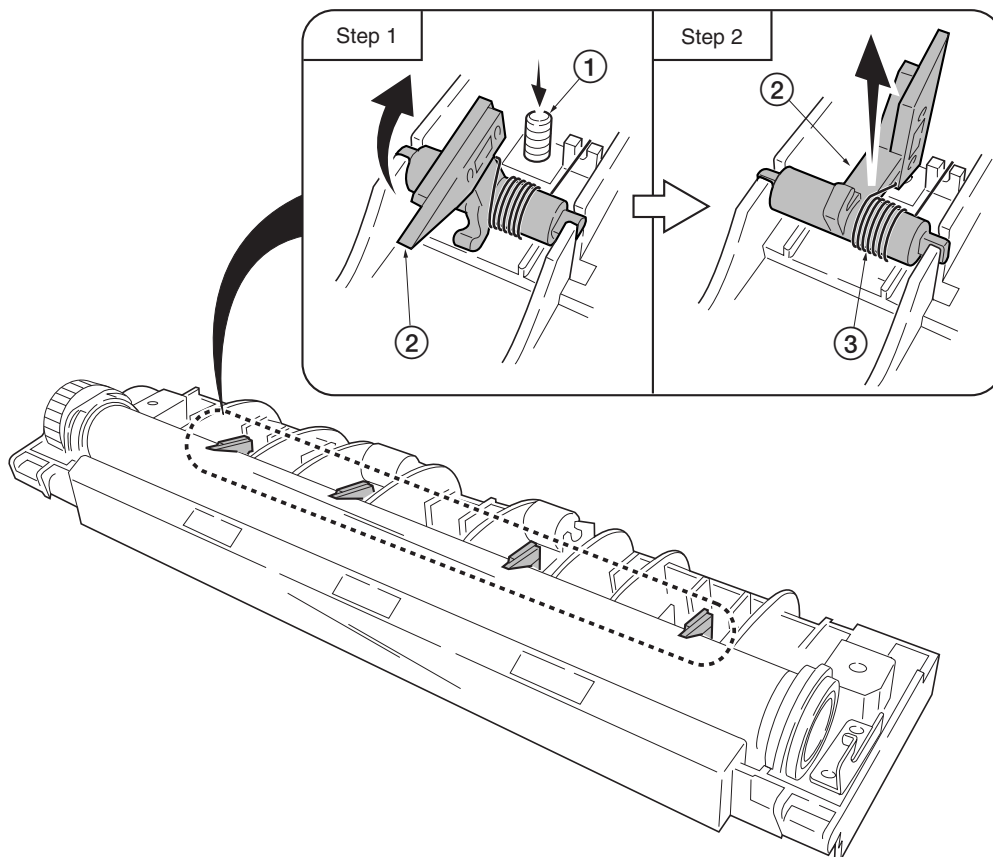

**Figure 5-2-21 Removing the separators**

## (2) Removing the heater lamp

### WARNING



The heater lamp is extremely hot immediately after the printer was running.

Allow substantial period of time until it cools down. Also, the heater lamp is fragile: Handle it with great care.

### CAUTION



The heater lamps are fragile. Use extreme care when handling not to drop or break.

Do not directly touch on the heater lamp. Finger prints on the heater lamp's outer surface can prevent proper fusing of toner on paper. When holding the heater lamp, hold the ceramic parts of heater lamp at both ends.

When refitting the heater lamp, direct the short distance side from the projection in the middle of the lamp facing the machine's left side.

1. Remove and split the fuser unit (See page 5-20).
2. Remove all (four) separators (See previous page).
3. Remove one screw ①, release the tension of lamp A holder ②.
4. Remove the heater lamp ③ from the lamp B holder ④.
5. Remove the heater lamp ③ from the heat roller ⑤.

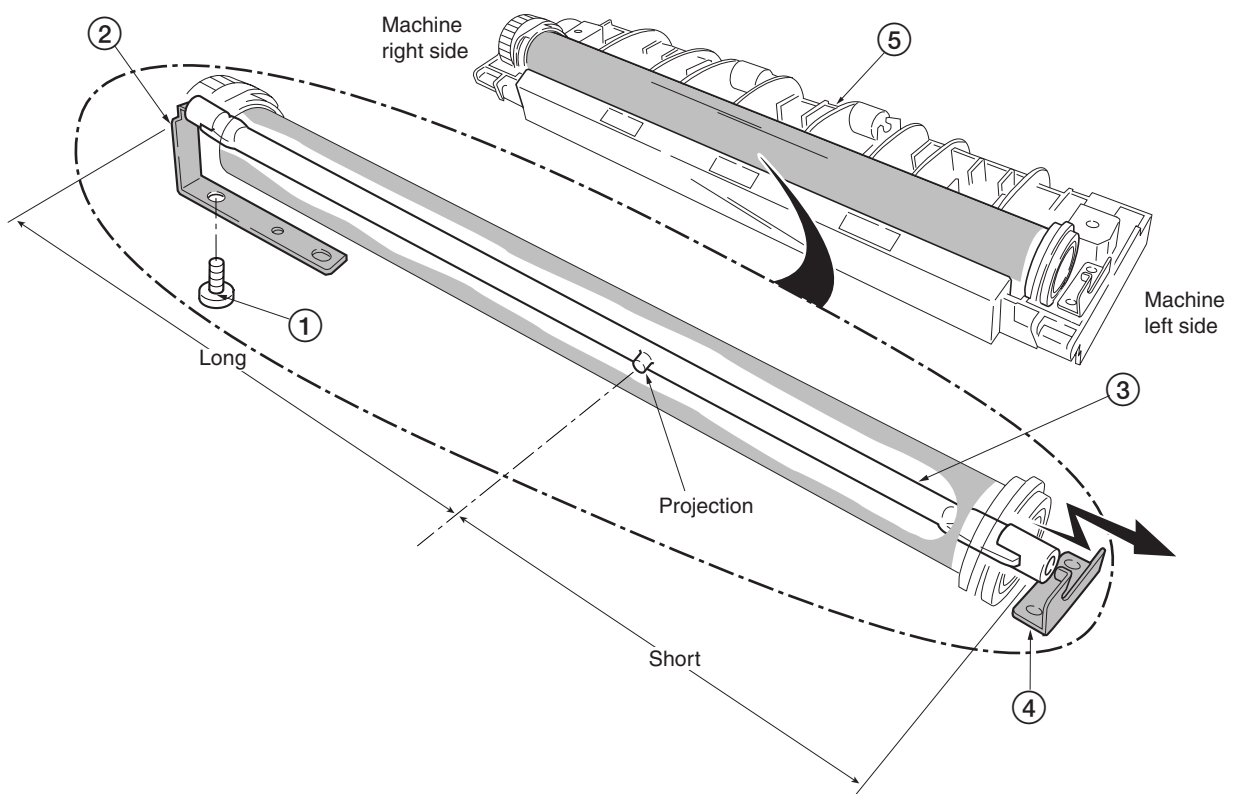

Figure 5-2-22 Removing the heater lamp

### (3) Removing the heat roller

**WARNING**



The heat roller is extremely hot immediately after the printer was running. Allow substantial period of time until it cools down.

1. Remove and split the fuser unit (See page 5-20).
2. Remove the heater lamp (See previous page).
3. Press the lamp A holder ① away from the heat roller. Pull up both heat R bush ② and heat L bush ③ at the same time.

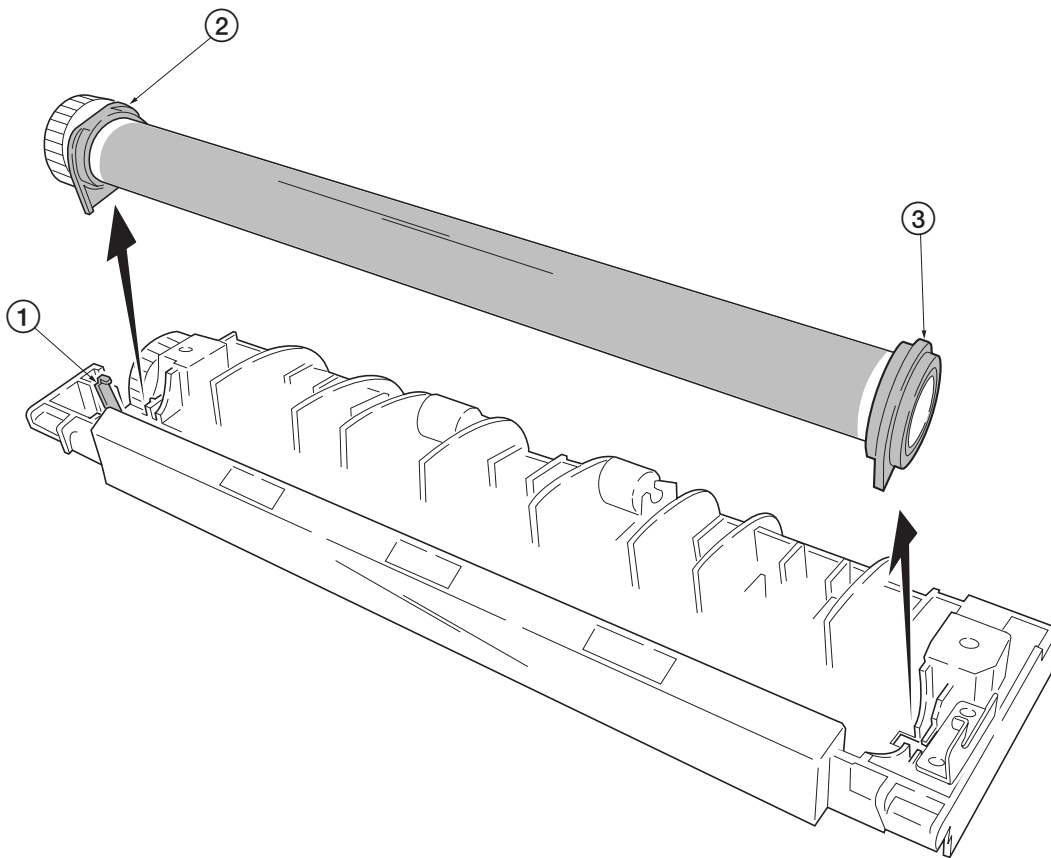

**Figure 5-2-23 Removing the heat R bush and heat L bush**



3. Remove the heat gear Z33 (4), heat R bush (2), and heat L bush (3) from the heat roller (5).

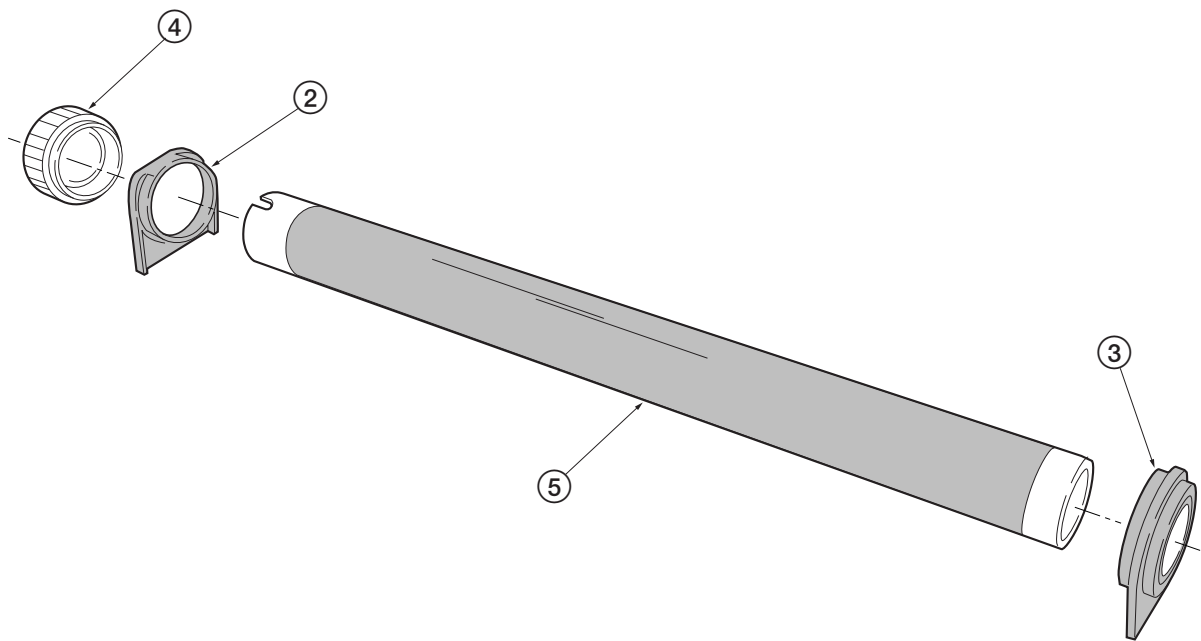

**Figure 5-2-24 Removing the heat roller**

#### (4) Removing the thermistor

1. Remove and split the fuser unit (See page 5-20).
2. Remove the heater lamp (See page 5-23).
3. Remove the heat roller (See page 5-24).
4. Remove one screw ①.
5. Remove the thermistor ②.

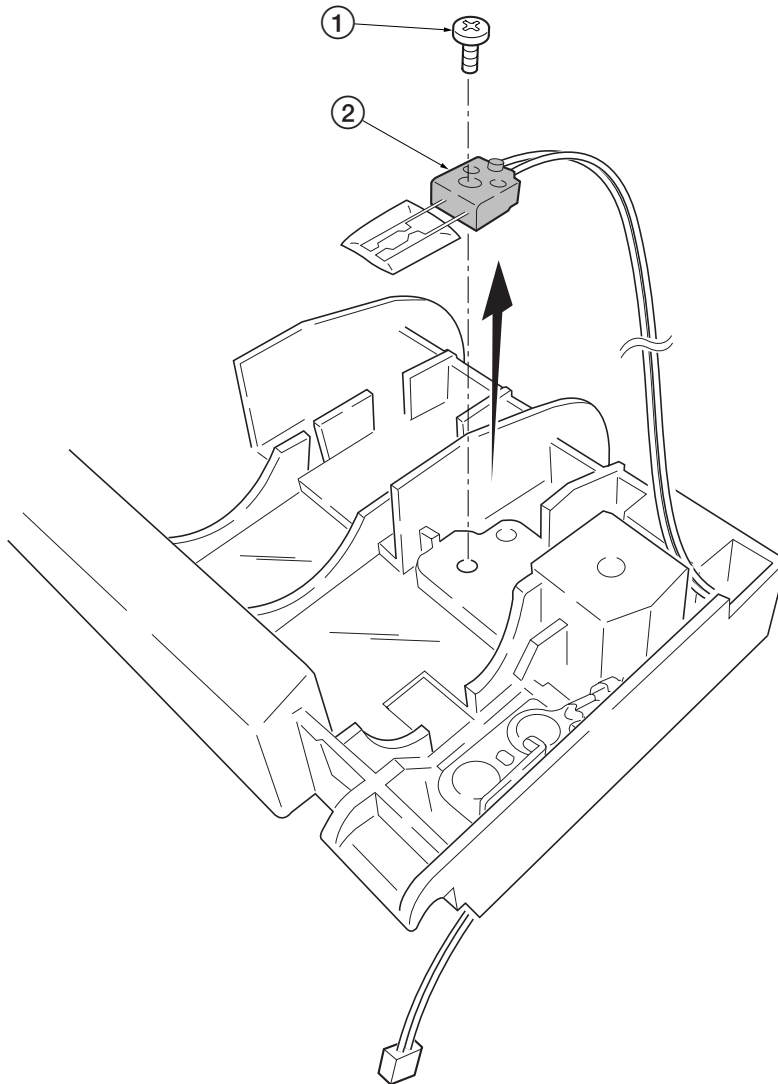

Figure 5-2-25 Removing the thermistor

## (5) Removing the thermal cutout

**CAUTION** Do not bend the terminals of the thermal cutout.



1. Remove and split the fuser unit (See page 5-20).
2. Remove the heater lamp (See page 5-23).
3. Remove the heat roller (See page 5-24).
4. Remove the two screws ①.
5. Remove the thermal cutout ②.

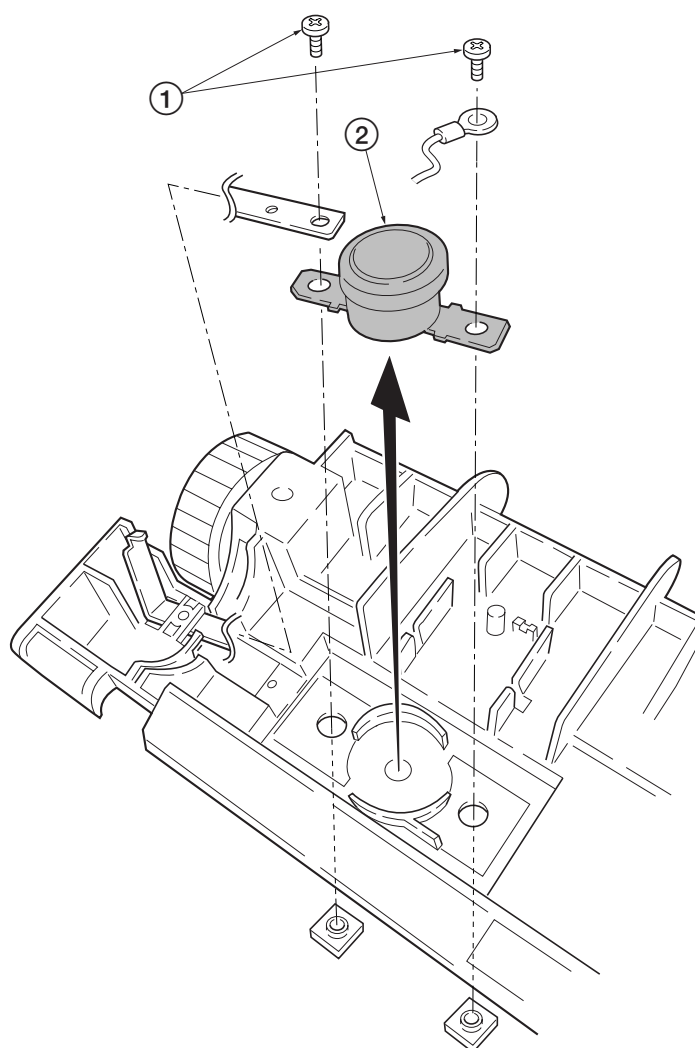

**Figure 5-2-26 Removing the thermal cutout**

## (6) Removing the press roller

### WARNING



The press roller is extremely hot immediately after the printer was running. Allow substantial period of time until it cools down.

1. Remove and split the fuser unit (See page 5-20).
2. Remove the press roller ① from the fuser unit ②.

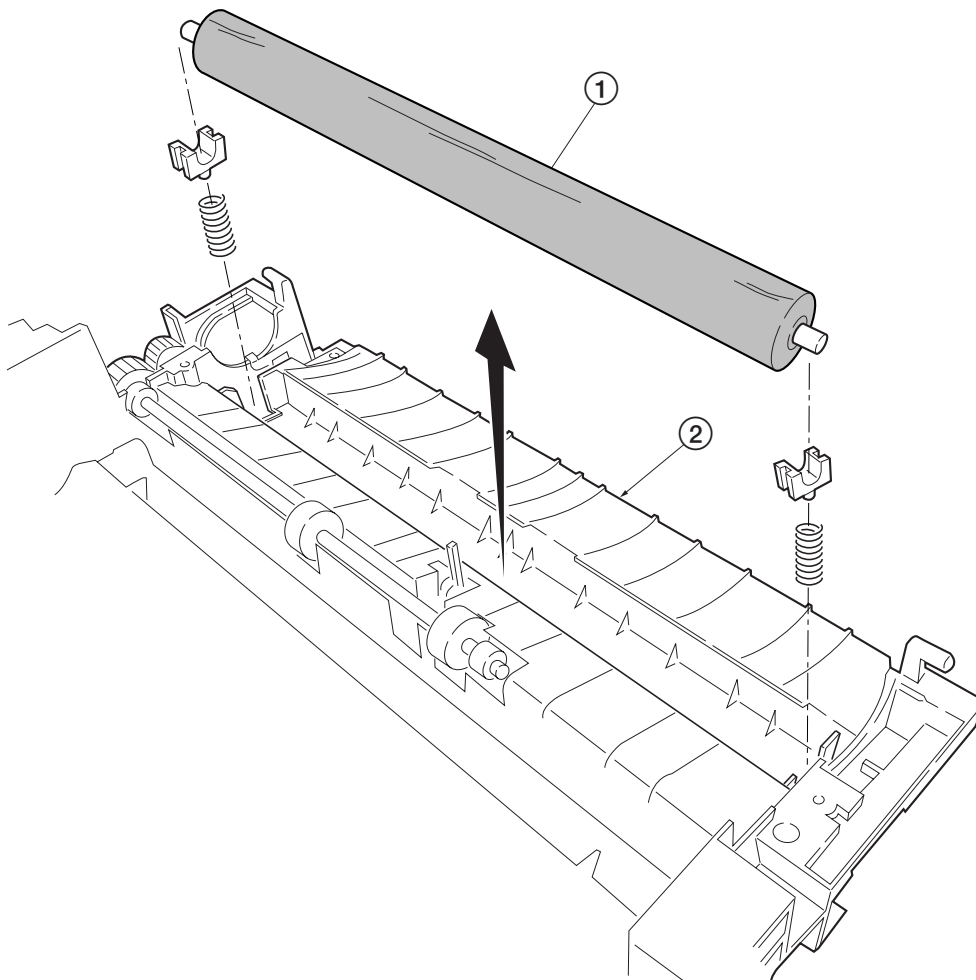

Figure 5-2-27 Removing the press roller

### 5-2-9 Removing the laser scanner unit and the eraser lamp

1. Remove the process unit (See page 5-4).
2. Remove the top cover/face-down output tray, right cover, and the left cover (See pages 5-5 and 5-6).
3. Remove four connectors (1).
4. Remove five screws (2) and four screws (3).
5. While keeping the ground joint plate (4) away from the LSU plate (5), remove the LSU plate.

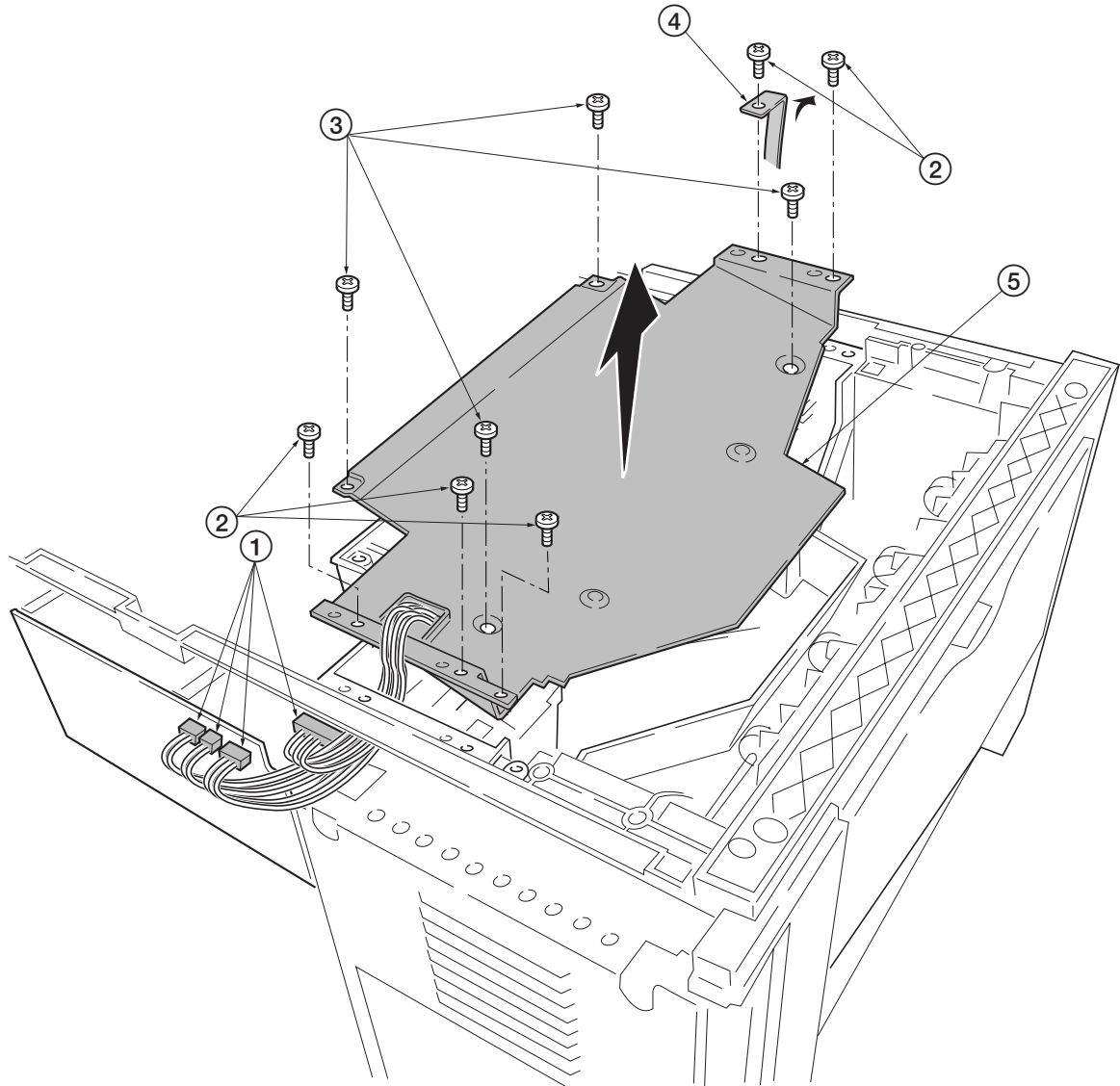
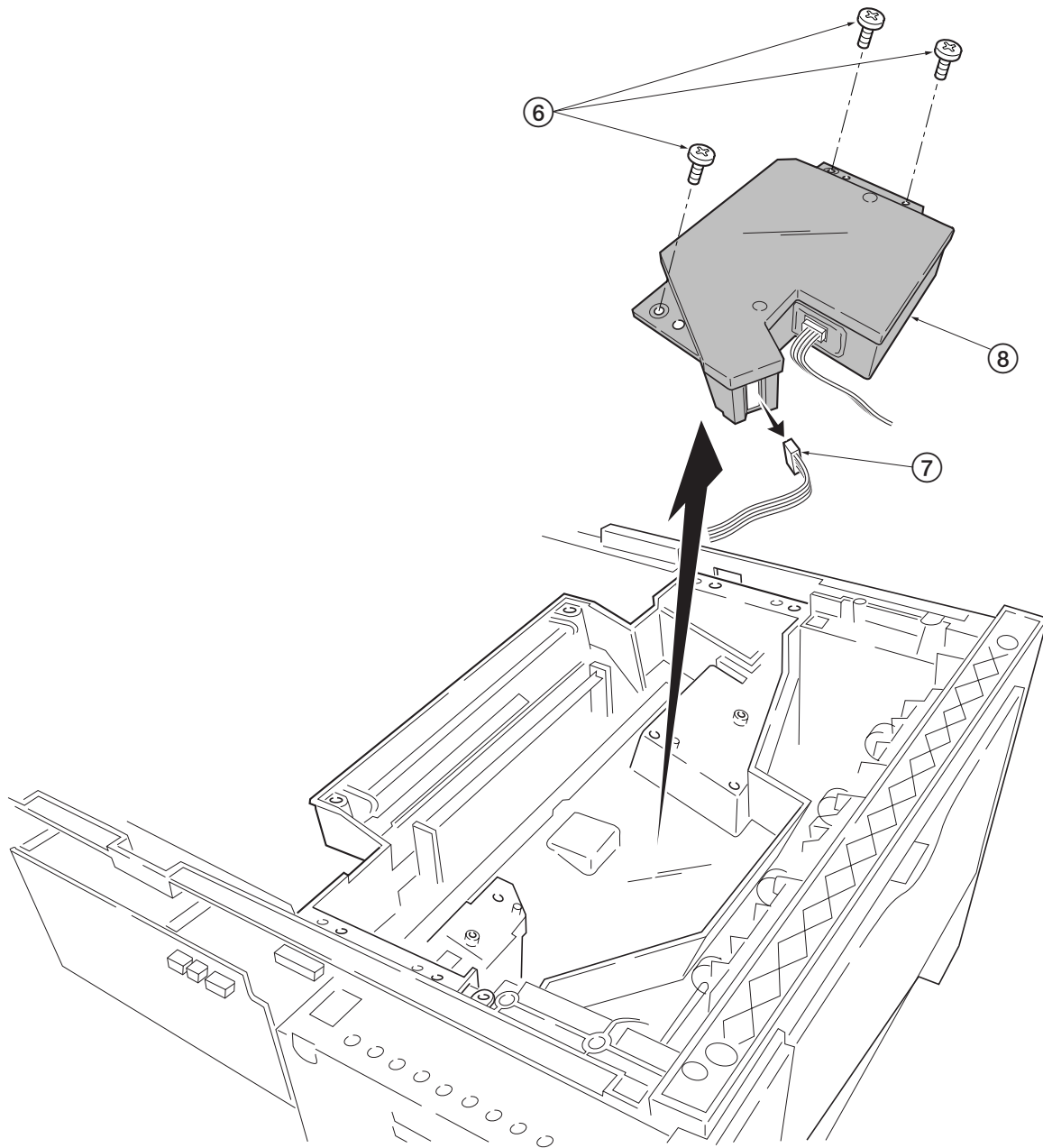

Figure 5-2-28 Removing the LSU plate

5. Remove three screws (6).
6. Remove one connector (7) from the laser scanner unit (8).
7. Remove the laser scanner unit (8).



**Figure 5-2-27 Removing the laser scanner unit**

8. Remove the eraser lamp ⑨.

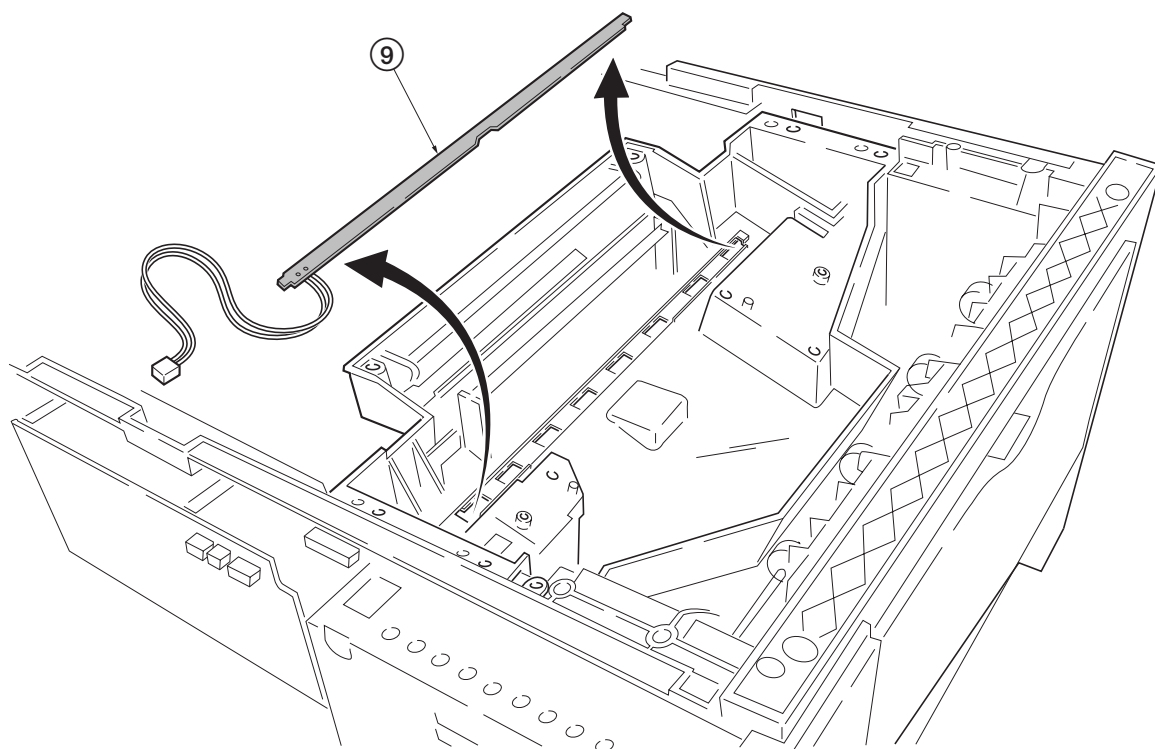

**5-2-28 Removing the eraser lamp**

## 5-2-10 Removing the main charger unit

1. Remove the process unit from the printer (See page 5-4).
2. Unlatch the three snaps (1), and remove the main charger cap (2).
3. Draw the main charger unit (3) in the direction of arrow (A), then pull it out in the direction of arrow (B).

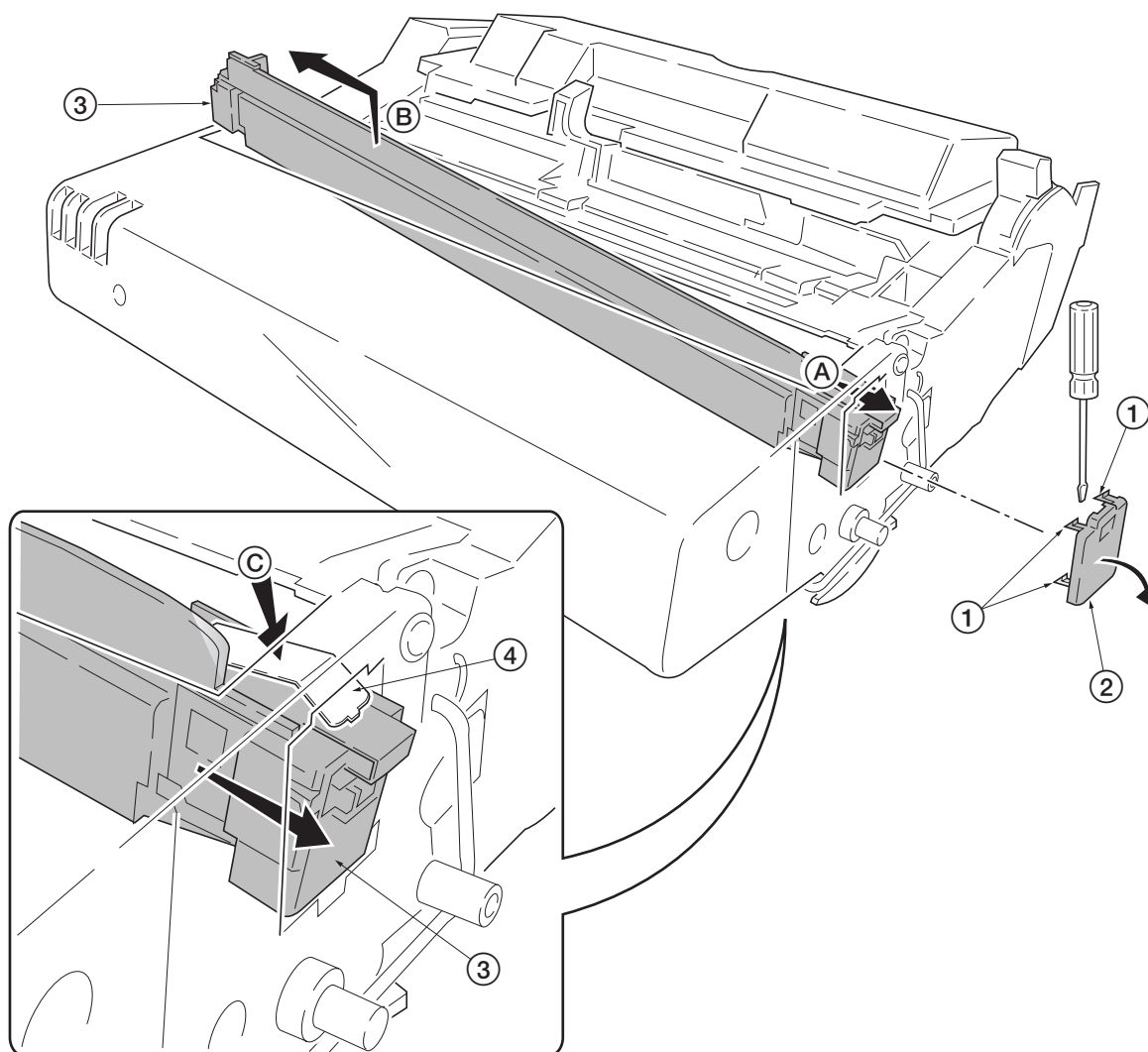

## 5-2-29 Removing the main charger unit

### CAUTION



When refitting the main charger unit (3), hold terminal (4) down (C), then push frontwards. Use care not to deform the terminal (4).



# Chapter 6    T r o u b l e s h o o t i n g

## Chapter 6 Contents

<b>6-1 Troubleshooting</b> .....	<b>6-3</b>
6-1-1 General error handling .....	6-3
(1) Maintenance messages .....	6-3
(2) Error messages .....	6-5
6-1-2 Diagnostic (Service error messages) .....	6-7
(1) Call service 7980 - Waste toner full [Total page count less than 100,000 pages of printing] .....	6-7
(2) Call service 7990 - Waste toner full [Total page count more than 100,000 pages of printing] .....	6-8
(3) Call service 2010 - Main motor error .....	6-9
(4) Call service 4000 - Laser scanner unit [Polygon motor] error .....	6-10
(5) Call service 4200 - Laser scanner unit [Pin photo diode] error .....	6-12
(6) Call service 6110 - Fuser unit error .....	6-14
(7) Call service 5300 - Eraser lamp error .....	6-15
(8) Call service F010 - Controller checksum error .....	6-16
(9) Call service F020 - Controller RAM read/write error .....	6-16
6-1-3 Print quality problems .....	6-17
(1) Completely blank printout .....	6-18
(2) All-black printout .....	6-19
(3) Dropouts .....	6-20
(4) Black dots .....	6-21
(5) Black horizontal streaks .....	6-21
(6) Black vertical streaks .....	6-22
(7) Unsharpness .....	6-23
(8) Gray background .....	6-24
(9) Dirt on the top edge or back of the paper .....	6-25
Repetitive defects gauge .....	6-26
6-1-4 Correcting a paper jam .....	6-27
(1) Jam at the face-down and face-up trays .....	6-27
(2) Jam at the paper cassette .....	6-28
(3) Jam inside the printer .....	6-28

# 6-1 Troubleshooting

## 6-1-1 General error handling

### (1) Maintenance messages

Message	Corrective action
Add paper (paper source) (size)	The <b>ATTENTION</b> indicator flashes. Indicates that paper has run out. Supply paper according to the paper source (Cassette or MP tray) and paper size (A4, B5, A5, etc.) displayed.  The paper cassette is not properly closed. Make sure the paper cassette is closed securely.
Call service person F0	The <b>ATTENTION</b> indicator turns on and the <b>READY</b> indicator goes off. Indicates a problem with the controller and the operator panel. Call a service person. The printer does not operate when this message is displayed.
Call service ####	The <b>ATTENTION</b> indicator turns on. Indicates a controller error. Call a service person. The printer does not operate when this message is displayed.
Call service ####:0123456	The <b>ATTENTION</b> indicator turns on. Indicates a mechanical error. Call a service person. 0123456 indicates the number of printed pages.
Call service 7980:0123456	The <b>ATTENTION</b> indicator turns on. The waste toner reservoir is full. 0123456 indicates the number of printed pages. (See page 6-7)
Load MP tray (paper size)	The <b>ATTENTION</b> indicator turns on and the <b>READY</b> indicator flashes. Indicates that the cassette and data paper sizes do not match. The printer feeds from the MP tray when the paper in the cassette is of a different size than that of the print data. Put paper of the correct size in the MP tray then press the <b>GO</b> key to resume printing.
Option Interface Error           ##	The <b>ATTENTION</b> indicator flashes. Indicates that a failure has occurred with the optional network interface board. Check the optional interface installed in the printer.

Message	Corrective action
Paper jam #####	The <b>ATTENTION</b> indicator turns on and the <b>READY</b> indicator goes off. Indicates that paper is jammed in the printer. Open the top and/or front cover and pull out the jammed or misfed paper.
Paper path error	The <b>ATTENTION</b> indicator turns on. There isn't no paper cassette in the paper feeder, or the cassette is not inserted properly.
Replace toner TK-17	The <b>ATTENTION</b> indicator turns on and the <b>READY</b> indicator goes off. Indicates that the printer has stopped because toner has run out. Replace the toner container with a new one. Clean the printer after replacement.
Set paper Press GO	The <b>ATTENTION</b> indicator turns on and the <b>READY</b> indicator flashes. Indicates there is no paper in the MP tray. Add paper to the tray. Press the <b>GO</b> key to resume printing.
Close top cover	The <b>ATTENTION</b> indicator turns on and the <b>READY</b> indicator goes off. Indicates that either the top or front cover of the printer is open. Open and close again securely.
Toner low TK-17	The <b>ATTENTION</b> indicator flashes. Indicates that toner is running out. Replace the toner container with a new one. Clean the printer after replacement.
Warning image adapt	The <b>ATTENTION</b> indicator flashes. Indicates that the print job cannot be done at current resolution because there is not enough internal memory. Try adding memory or changing resolution.
Warning low memory	The <b>ATTENTION</b> indicator flashes. Indicates that the printer's memory is running low because of the number of downloaded fonts and macros. Print a status page to see how much user memory is left and try deleting unnecessary fonts and macros.
Warning Waste toner box	The <b>ATTENTION</b> indicator flashes. Indicates that the waste toner reservoir in the process unit is almost full. When it becomes full, the printer stops printing.

## (2) Error messages

Message	Corrective action
I/F occupied	This message appears when you attempt to use the printer's operator panel to change the environmental settings on the interface from which data are presently being received. The <b>ATTENTION</b> indicator flashes during 1.2 seconds, then it goes out and the message display returns to the previous screen.
KPDL error ## Press GO	The <b>ATTENTION</b> indicator is on and the <b>READY</b> indicator flashes. Indicates that a KPDL-related error has occurred. The current print processing cannot continue. To print out an error report, display > Print KPDL errs from the mode select menu, and select On . Press the <b>GO</b> key to resume printing. You can abandon printing by the <b>CANCEL</b> key.
Memory overflow Press GO	The <b>ATTENTION</b> indicator is on and the <b>READY</b> indicator flashes. Indicates that the total amount of data received by the printer exceeds the printer's internal memory. Press the <b>GO</b> key to resume printing. You can abandon printing by the <b>CANCEL</b> key.
MemoryCard err## Press GO	The <b>ATTENTION</b> indicator is on and the <b>READY</b> indicator flashes. Indicates that a error has occurred during access to the memory card using the PRESCRIBE RWER command or from the printer's operator panel. Look at the error code given in place of ## and refer to the corresponding description given below. 04: The capacity of the memory card is insufficient. Clean up files. 05: Specified file not on memory card. 06: No memory for use by memory card. Expand printer memory. Press the <b>GO</b> key to resume printing. You can abandon printing by the <b>CANCEL</b> key.

Message	Corrective action
Memory card err20	The <b>ATTENTION</b> indicator is on. The printer has halted, memory card is inserted or removed while the printer power is on.
Print overrun Press GO	<p>The <b>ATTENTION</b> indicator is on and the <b>READY</b> indicator flashes. Indicates that the data transferred to the printer was too complex to print on a page. Press the <b>GO</b> key to resume printing. (The page may break in some pages.) You can abandon printing by the <b>CANCEL</b> key.</p> <p><b>Note:</b> After this message is displayed, page protect mode is On. To maintain optimum use of memory during printing, display &gt;Page Protect from the operator panel, and reselect Auto.</p>
RAM disk error ## Press GO	<p>The <b>ATTENTION</b> indicator is on and the <b>READY</b> indicator flashes. Indicates a problem with the RAM disk. Indicates that the data transferred to the printer was too complex to print on a page. Look at the error code given in place of ## and refer to the corresponding description given below.</p> <p>01: Abnormal format. Try restarting the printer.</p> <p>02: RAM disk mode is Off. Turn RAM disk mode On.</p> <p>04: No disk space. Clean up files.</p> <p>05: Specified file not on disk.</p> <p>06: No memory for use by disk system. Expand printer memory.</p> <p>Press the <b>GO</b> key to resume printing. You can abandon printing by the <b>CANCEL</b> key.</p>

## 6-1-2 Diagnostic (Service error messages)

The printer does not operate when a message beginning with “Call service #####” or “Call service person F0##” is displayed. The message is categorized as follows:

### (1) Call service 7980 - Waste toner full [Total page count less than 100,000 pages of printing]

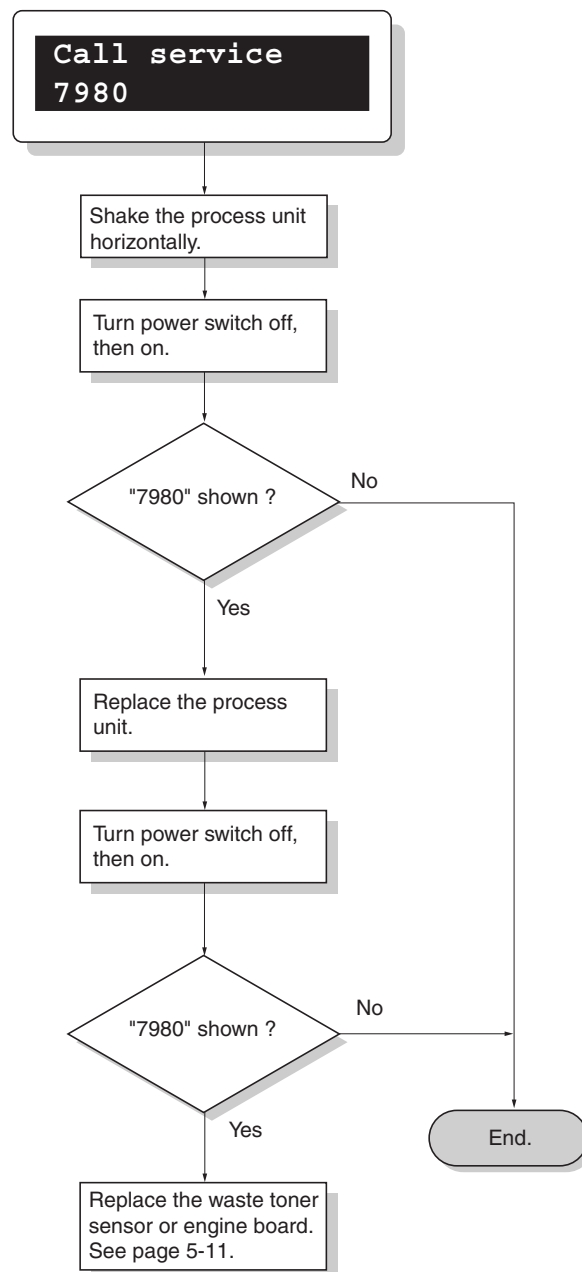

(2) Call service 7990 - Waste toner full [Total page count more than 100,000 pages of printing]

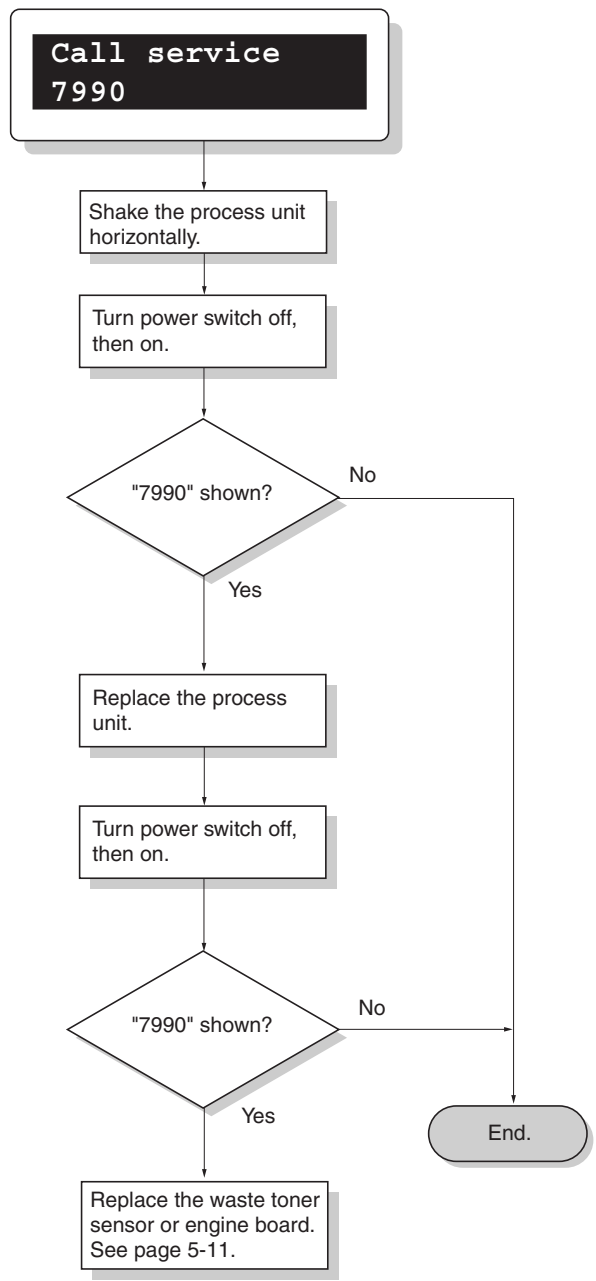



### (3) Call service 2010 - Main motor error

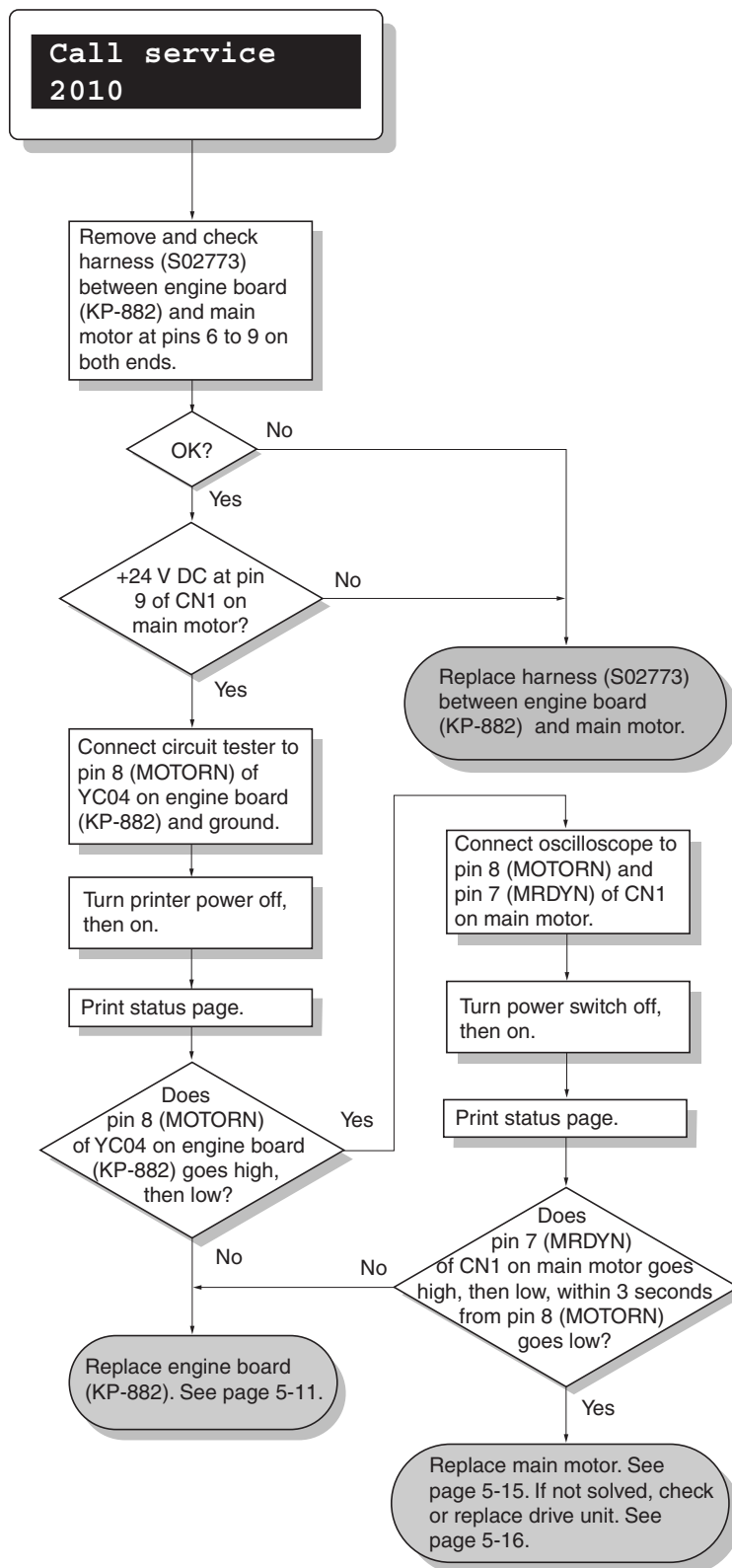

**(4) Call service 4000 - Laser scanner unit [Polygon motor] error**

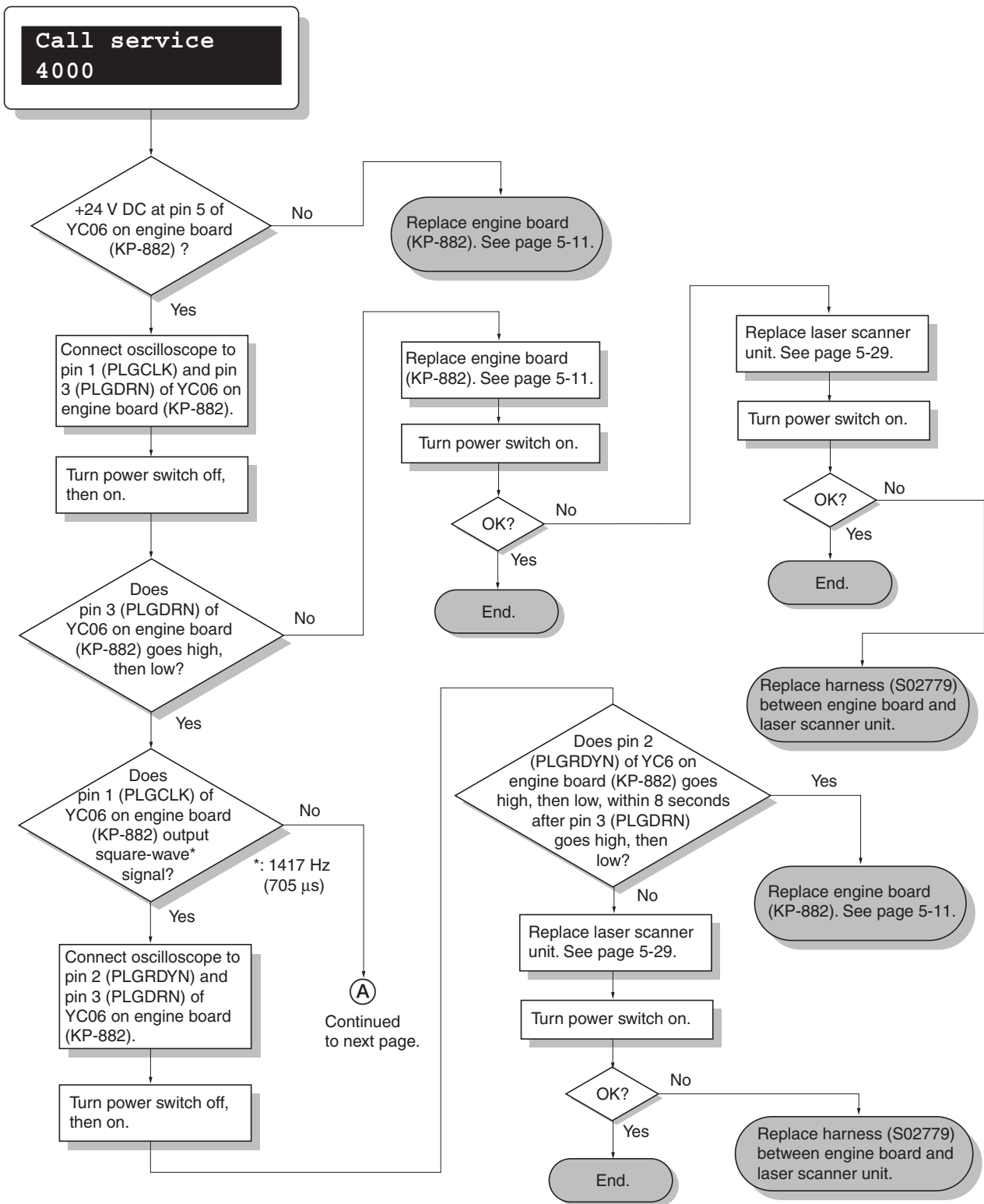

Continued  
from previous page.

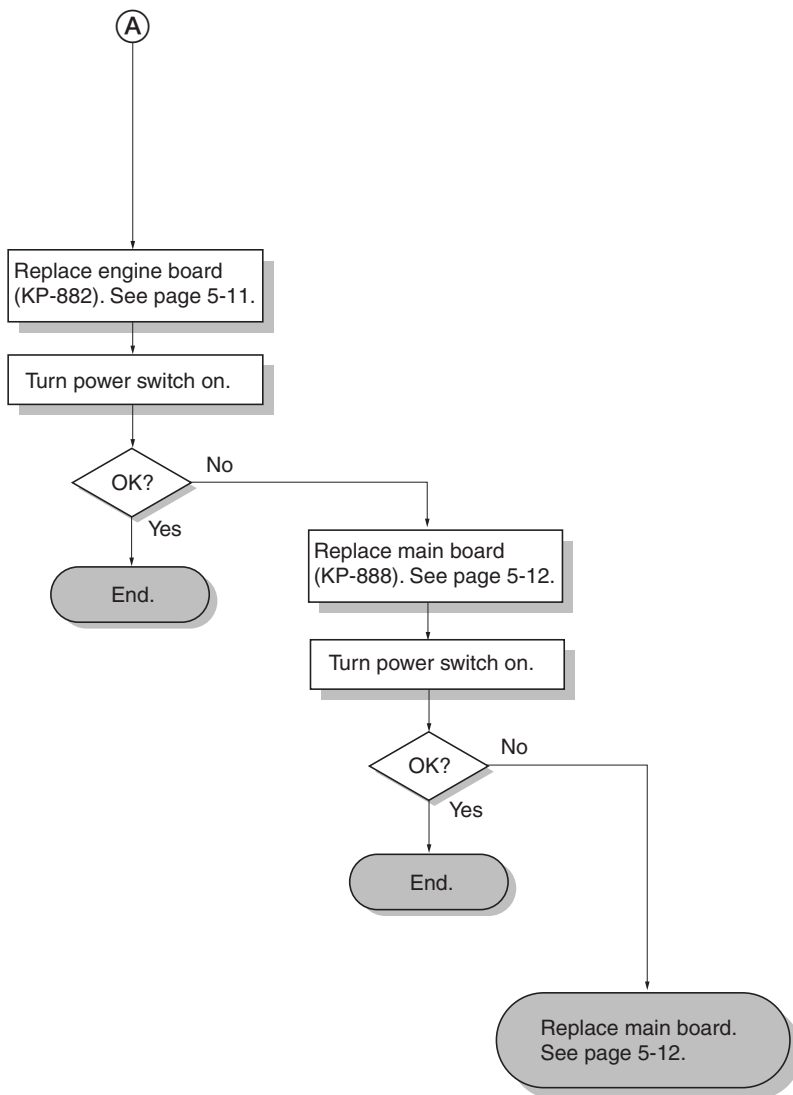

**(5) Call service 4200 - Laser scanner unit [Pin photo diode] error**

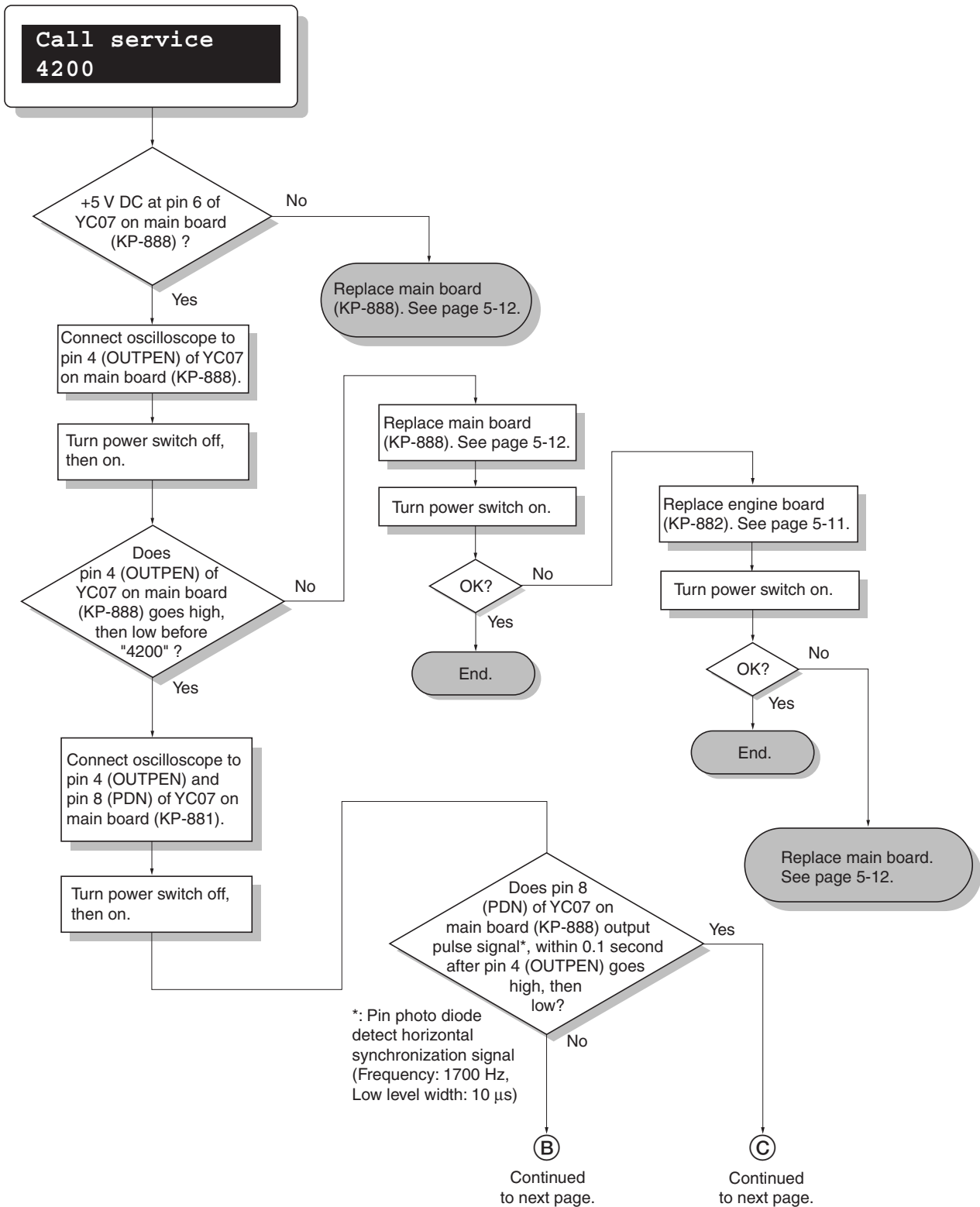

Continued from previous page.

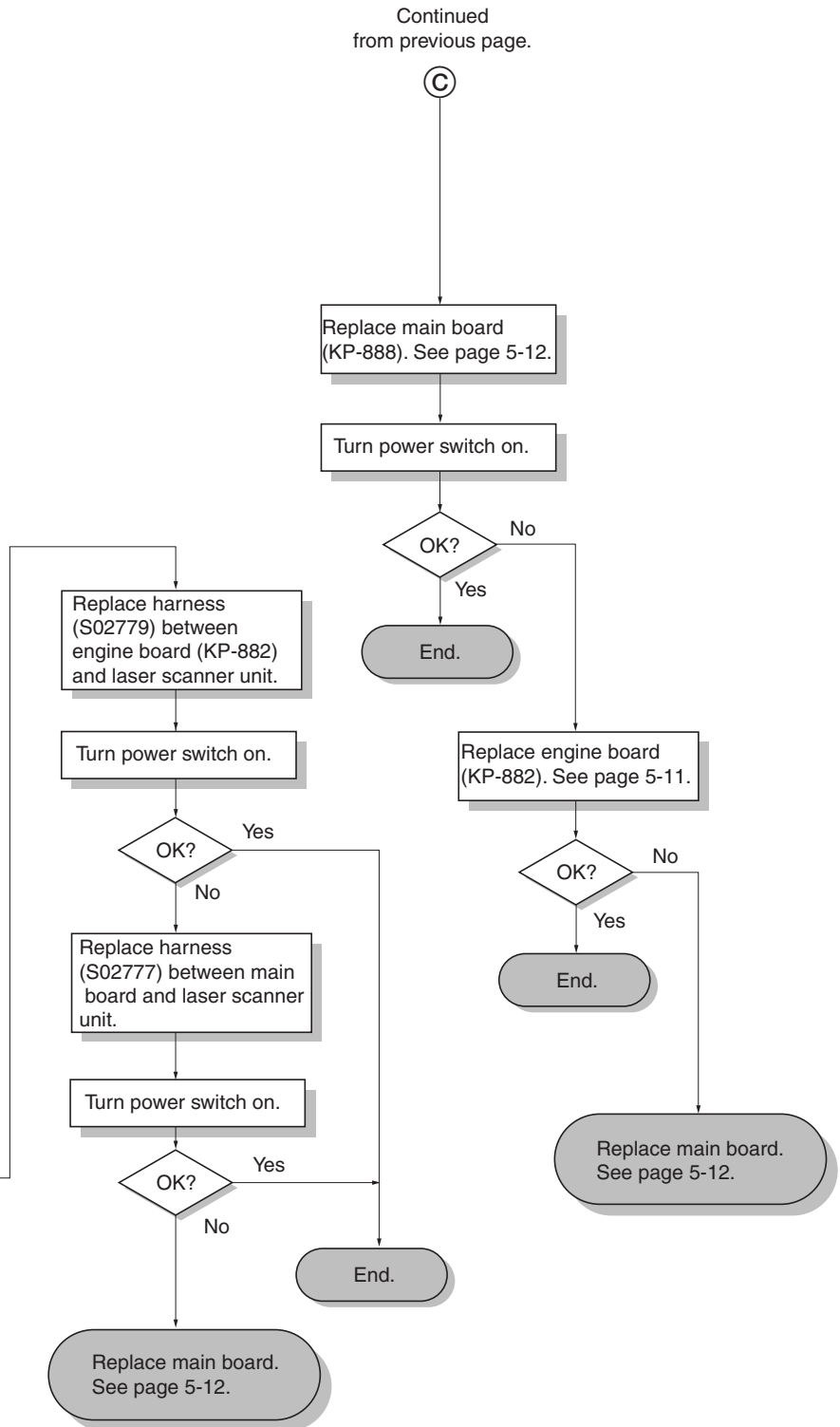
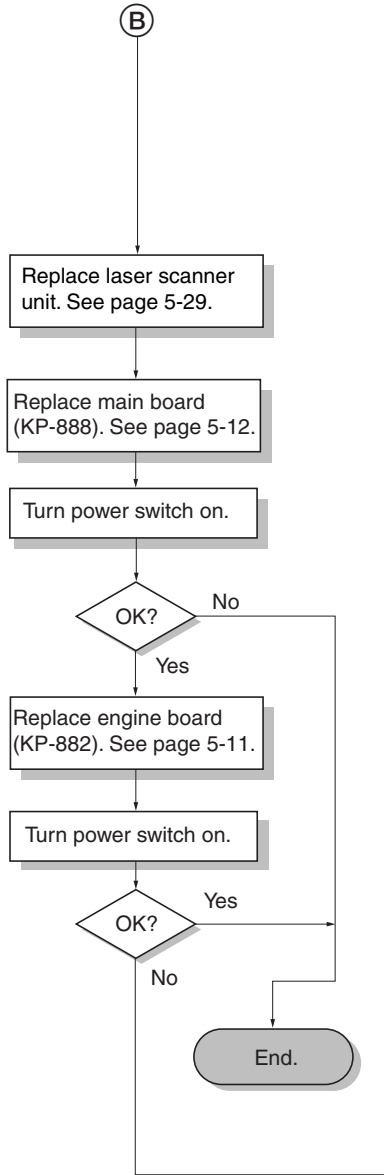

## (6) Call service 6110 - Fuser unit error

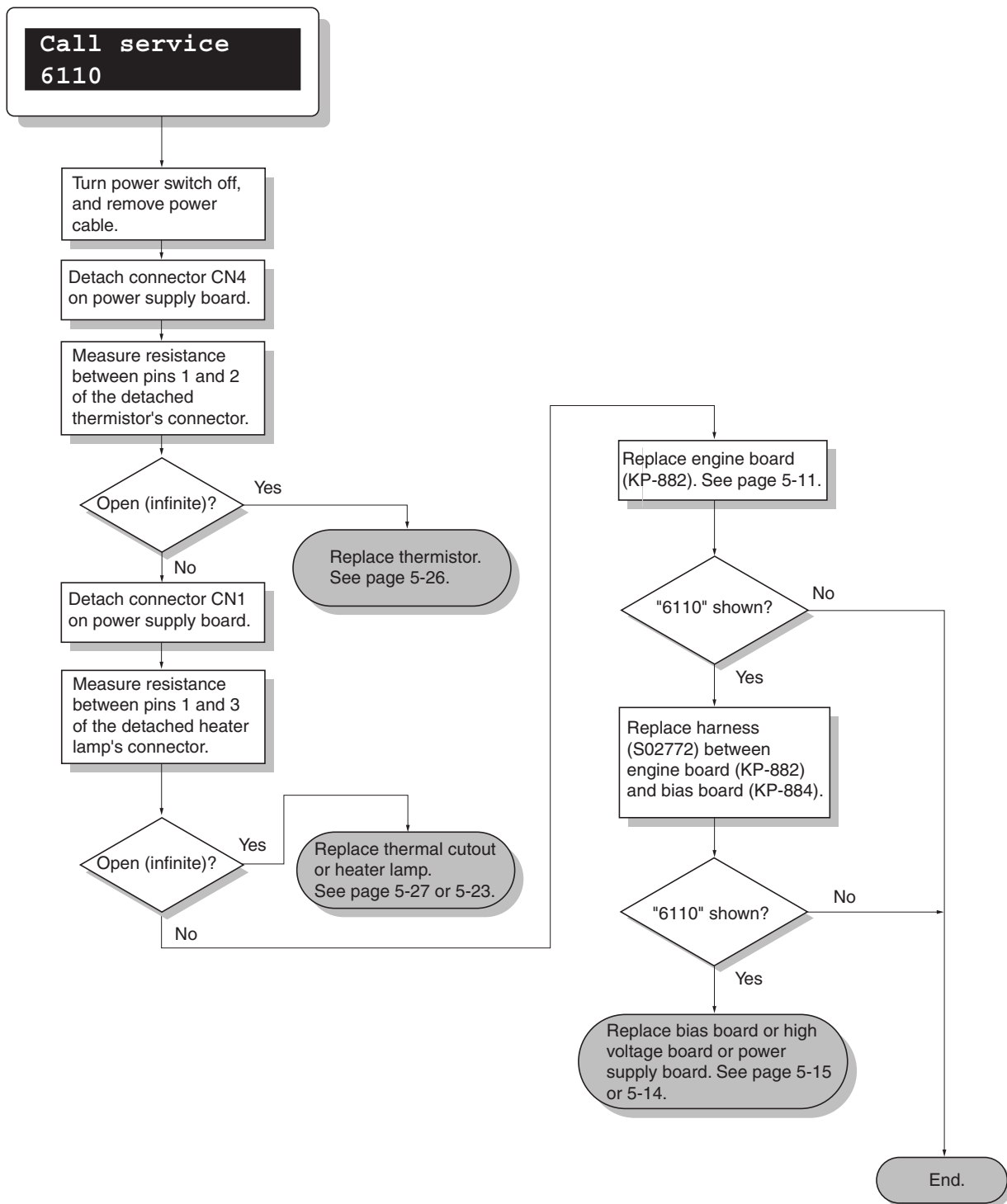

## (7) Call service 5300 - Eraser lamp error

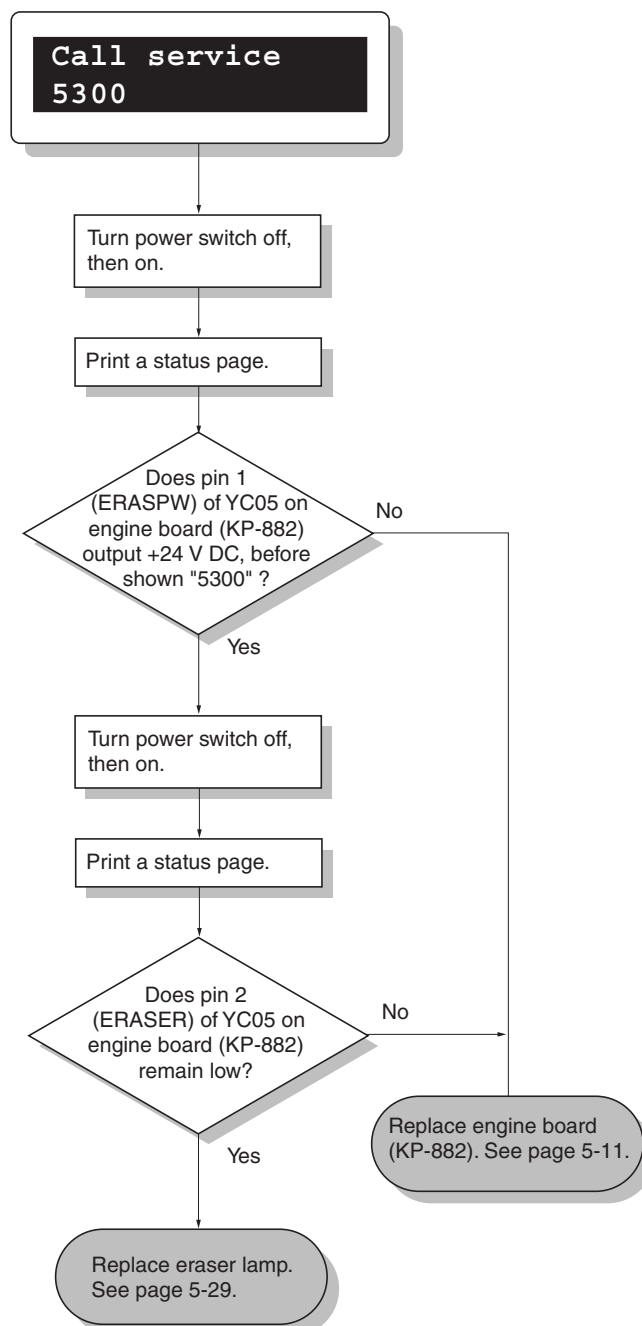

**(8) Call service F010 - Controller checksum error**

Turn power switch off, then on. If not solved, replace the main board (See page 5-12).

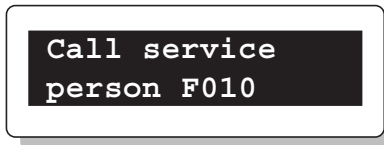

**(9) Call service F020 - Controller RAM read/write error**

Remove the expansion memory (DIMM). Turn power switch off, then on. If not solved, replace the main board. If solved, replace the expanding memory (See pages 2-8 and 5-12).

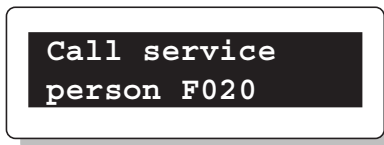



### 6-1-3 Print quality problems

Print quality problems range from uneven tone to completely blank output. The troubleshooting procedure for each type of problem is given below.

**(1) Completely blank printout**

See page 6-18.

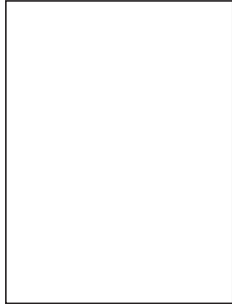

**(2) All-black printout**

See page 6-19.



**(3) Dropouts**

See page 6-20.

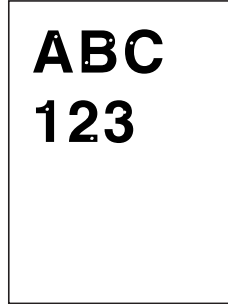

**(4) Black dots**

See page 6-21.

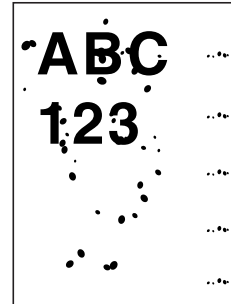

**(5) Black horizontal streaks**

See page 6-21.

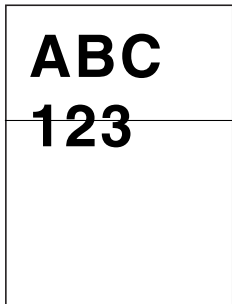

**(6) Black vertical streaks**

See page 6-22.

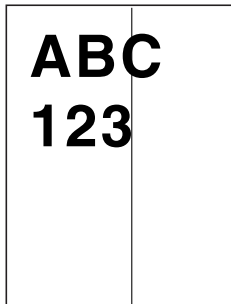

**(7) Unsharpness**

See page 6-23.

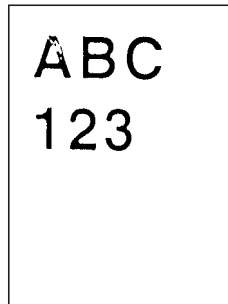

**(8) Gray background**

See page 6-24.

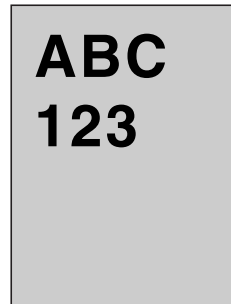

**(9) Dirt on the top edge or back of the paper**

See page 6-25.

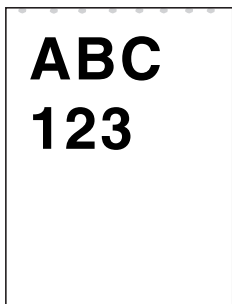

**(1) Completely blank printout**

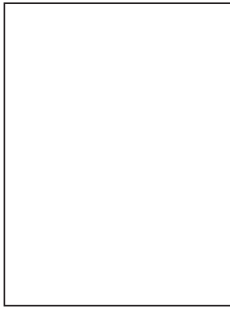

Check the process unit.

- Check that the process unit is inserted correctly.

Check the transfer bias potential.

- Check the transfer bias output on the high voltage board. This requires removal of the left cover and the test equipment. Replace the high voltage board if high voltage potential is not available on the board (See page 5-13).

Check the laser scanner unit.

- The scanner components within the scanner may be disordered. Replace the laser scanner unit if necessary (See page 5-28).

## (2) All-black printout



Check the main charger.

- Open the printer top cover and check that the process unit is correctly seated. Poor contact main charger terminal between the process unit and the printer main unit.

Check the drum bias.

- Make sure the bias from the high voltage board correctly arrives at the process unit.

Check high voltage potential at the high voltage board.

- Check the high voltage output on the high voltage board. Replace the high voltage board if high voltage potential is not available on the board.

### (3) Dropouts

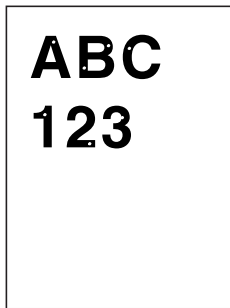

Note the spacing of the defects. Refer to *Repetitive defects gauge* (See page 6-26).

- If the defects occur at regular intervals of 63 mm, the problem may be the damaged developing roller (in the process unit). Replace the process unit.
- If the defects occur at regular intervals of 94 mm, the problem may be the damaged drum (in the process unit). Replace the process unit.
- If the defects occur at regular intervals of 61 mm, the problem may be the damaged fuser unit. Replace the press roller or heat roller (See page 5-27 or 5-13).

Check paper for property.

- Paper with rugged surface or dump tends to cause dropouts. Replace paper with the one that satisfies the paper specifications.

Check the transfer roller installation.

- The transfer roller must be supported by the bushes at the both ends. Clean the bush to remove oil and debris. Replace the transfer roller if necessary (See page 5-9).

Check the transfer bias potential.

- Check the transfer bias output on the high voltage board. This requires removal of the left cover and the test equipment. Replace the high voltage board if high voltage potential is not available on the board (See page 5-9).

#### (4) Black dots

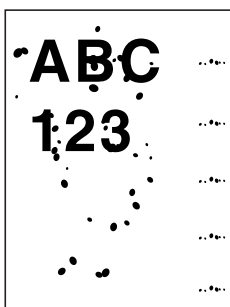

Note the spacing of the defects. Use the *Repetitive defects gauge* (See page 6-26).

- If the defects occur at regular intervals of 94 mm, the problem may be the damaged drum (in the process unit). Replace the process unit.
- If the defects occur at random intervals, the toner may be leaking from the process unit. Replace the process unit.

#### (5) Black horizontal streaks

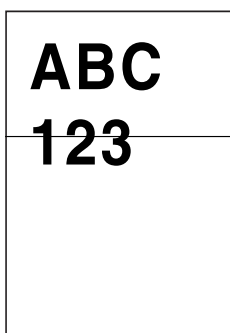

Check the process unit's ground of the process unit.

- The drum axle in the process unit and its counter part, the grounding tab in the printer, must be in a good contact. If necessary, apply a small amount of electro-conductive grease onto the tab.

The drum may be defective.

- Replace the process unit.

## (6) Black vertical streaks

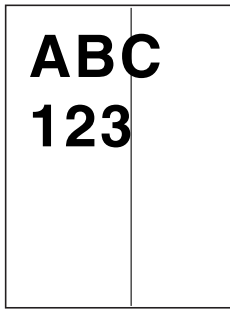

Contaminated main charger wire.

- Clean the main charger wire by pulling the green colored cleaning knob in and out several times.

Check the drum surface for a streak of toner laying lengthwise.

- A streak of toner remaining on drum after printing means that the cleaning blade (in the process unit) is not working properly. Replace the process unit.

Defective magnet roller (in the process unit).

- Replace the process unit.

## (7) Unsharpness

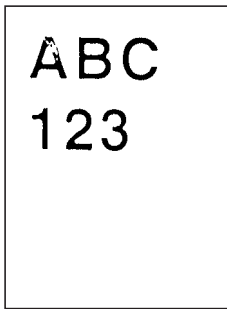

Check paper for property.

- Paper with rugged surface or dump tends to cause unsharp printing. Replace paper with the one that satisfies the paper specifications.

Check the transfer roller installation.

- The transfer roller must be supported by the bushes at the both ends. Clean the bush to remove oil and debris. Replace the transfer roller if necessary (See page 5-9).

Check the transfer bias potential.

- Check the transfer bias output on the high voltage board. This requires removal of the left cover and the test equipment. Replace the high voltage board if high voltage potential is not available on the board (See page 5-13).

Check *EcoPrint* setting.

- The *EcoPrint* mode can provides faint, unsharp printing because it acts to conserve toner for draft printing purpose. For normal printing, turn off by using the operator panel (MENU) For details refer to the printer's *User's Manual*.

## (8) Gray background

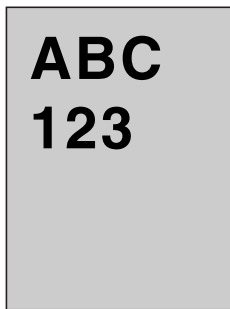

Check the print density setting.

- The print density may be set too high. Try adjusting the print density using the *Remote operation panel* utility. For details refer to the printer's *User's Manual*.

Check the surface potential of the drum (in the process unit).

- The drum potential should be approximately 400 V. This may vary depending on production lots. Measurement is possible only by using the jig and tool specifically designed for this purpose. The drum unit will have to be replaced if it bears values far out of the allowable range.

The developing roller (in the process unit) may be defective.

- If a process unit which is known to work normally is available for check, replace the current process unit in the printer with the normal one. If the symptom disappears, replace the process unit with a new one.



**(9) Dirt on the top edge or back of the paper**

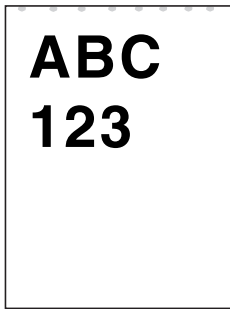

Check toner contamination in various parts.

- Dirty edges and back of the paper can be caused by toner accumulated on such parts as the paper chute, paper transportation paths, the bottom of the process unit, and the fuser unit inlet. Clean these areas and parts to remove toner.

Check the transfer roller.

- If the transfer roller is contaminated with toner, clean the transfer roller using a vacuum cleaner; or by continuously printing a low-density page until the symptom has faded away.

## Repetitive defects gauge

Use the following measurements for checking repetitive occurrences on the printed page. See the above section for details.

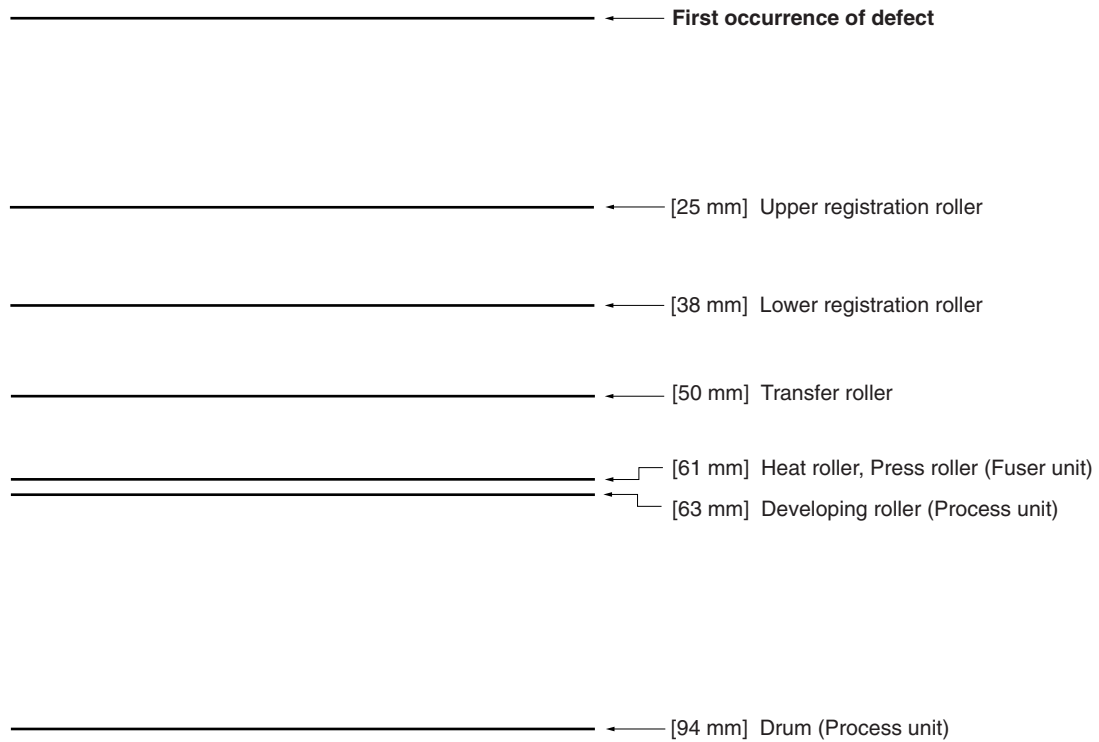

**Figure 6-1-2 Repetitive defects gauge**

#### **6-1-4 Correcting a paper jam**

If a paper jam occurs while you are printing, remove the jammed paper as described below. After you have removed the jammed paper, open and close the top cover once.

##### **(1) Jam at the face-down and face-up trays**

1. Open the face-up tray and remove the jammed paper as shown in the figure.

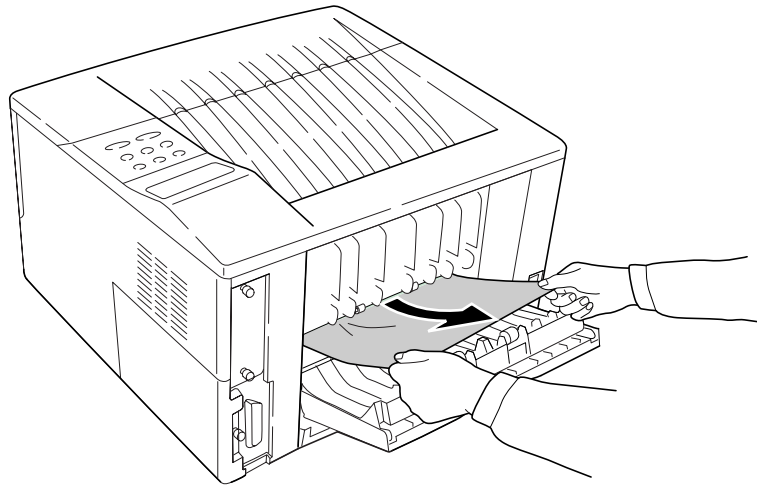

**Figure 6-1-3 Jam at the face-down and face-up trays**

## **(2) Jam at the paper cassette**

1. Pull out the paper cassette and remove the jammed paper.

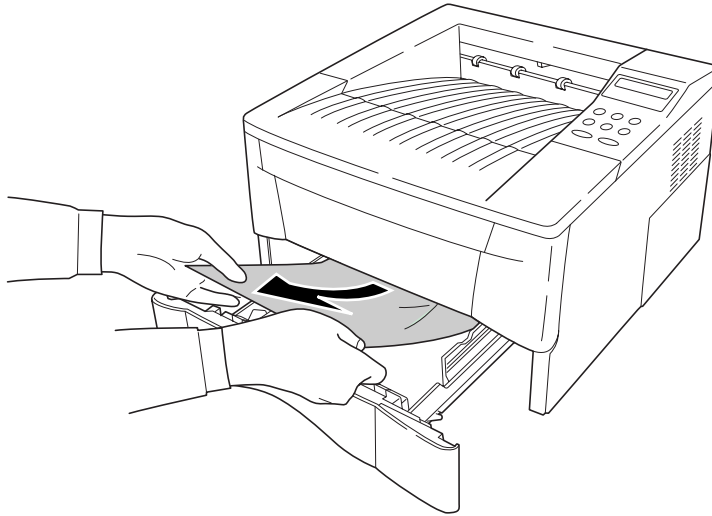

**Figure 6-1-4 Jam at the paper cassette**

## **(3) Jam inside the printer**

1. Open the top cover and front cover.
2. Take the process unit together with the toner container out of the printer.
3. Remove the jammed paper.

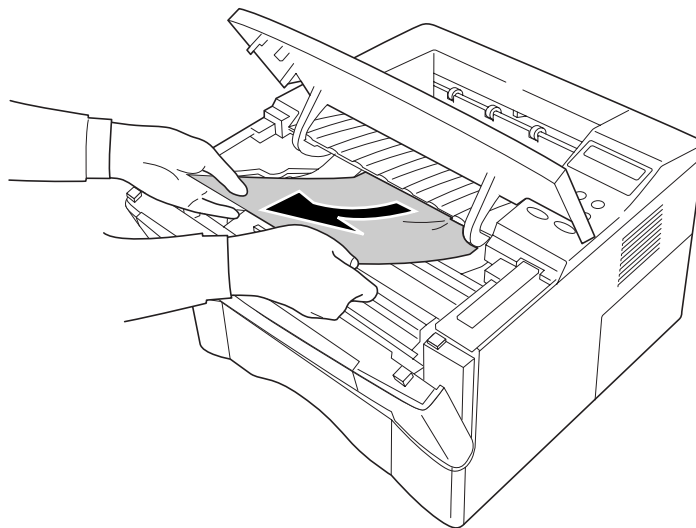

**Figure 6-1-5 Jam inside the printer**

# Appendix A    D i a g r a m s

# Appendix A Contents

<b>Timing charts</b> .....	<b>A-3</b>
1. Option paper cassette feeding, two A4 size papers .....	A-3
2. Option paper cassette feeding, two legal size papers .....	A-4
3. Option paper cassette feeding, two letter size papers .....	A-5
4. MP tray feeding, two A4 size papers .....	A-6
5. MP tray feeding, two legal size papers .....	A-7
6. MP tray feeding, two letter size papers .....	A-8
<b>Wiring diagram</b> .....	<b>A-9</b>

# Timing charts

## 1. Option paper cassette feeding, two A4 size papers

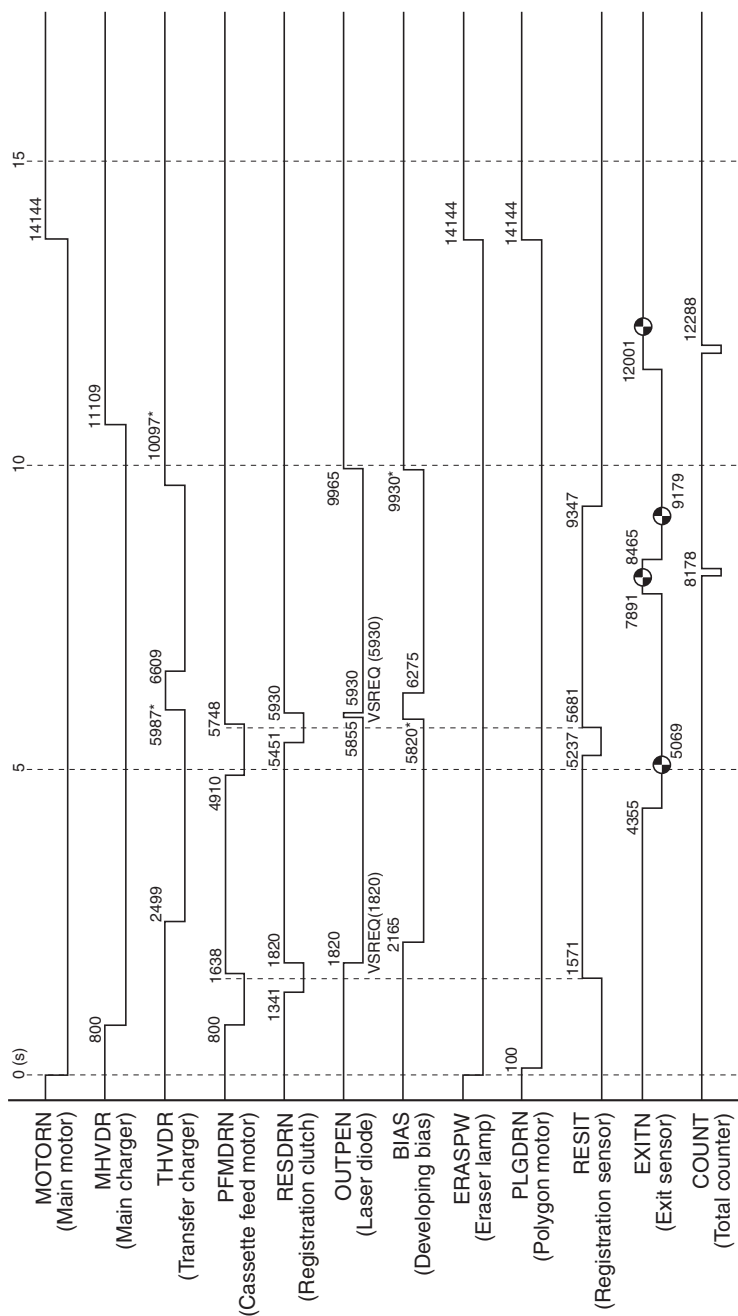

Drum speed: 84.00 mm/s  
 Paper feeding speed: 240.00 mm/s  
 Printing speed: 14.30 ppm

\*: Varies depending on paper size.



●: Jam detection timing

## 2. Option paper cassette feeding, two legal size papers

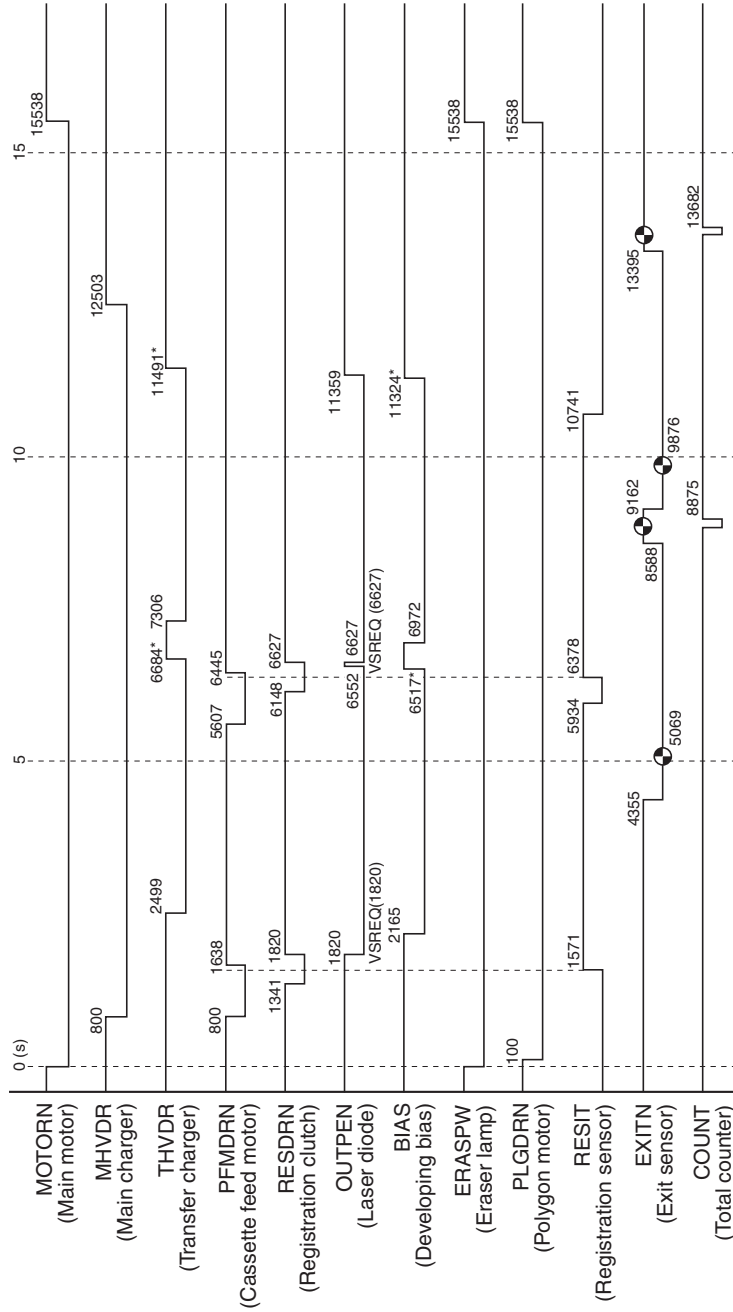

Drum speed: 84.00 mm/s  
 Paper feeding speed: 240.00 mm/s  
 Printing speed: 12.14 ppm

\*: Varies depending on paper size.

●: Jam detection timing



### 3. Option paper cassette feeding, two letter size papers

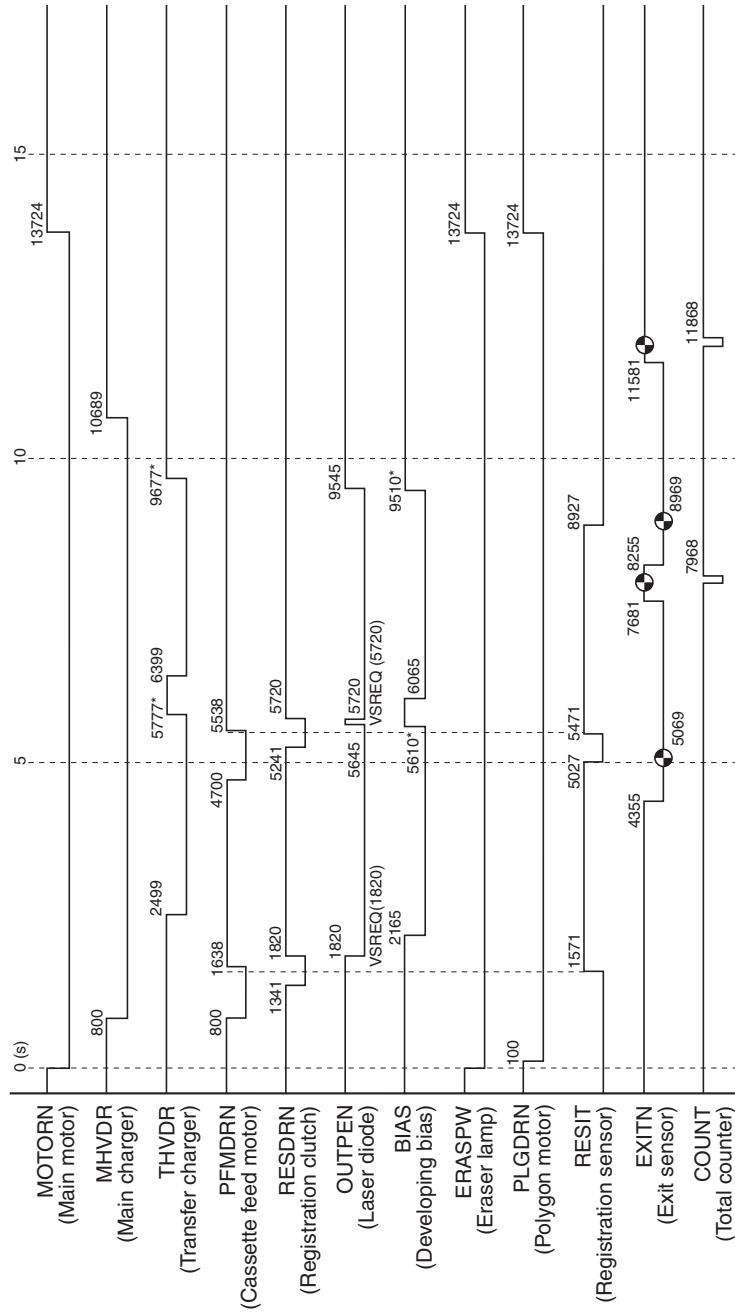

\*: Varies depending on paper size.

Drum speed: 84.00 mm/s

Paper feeding speed: 240.00 mm/s

Printing speed: 14.81 ppm

●: Jam detection timing

## 4. MP tray feeding, two A4 size papers

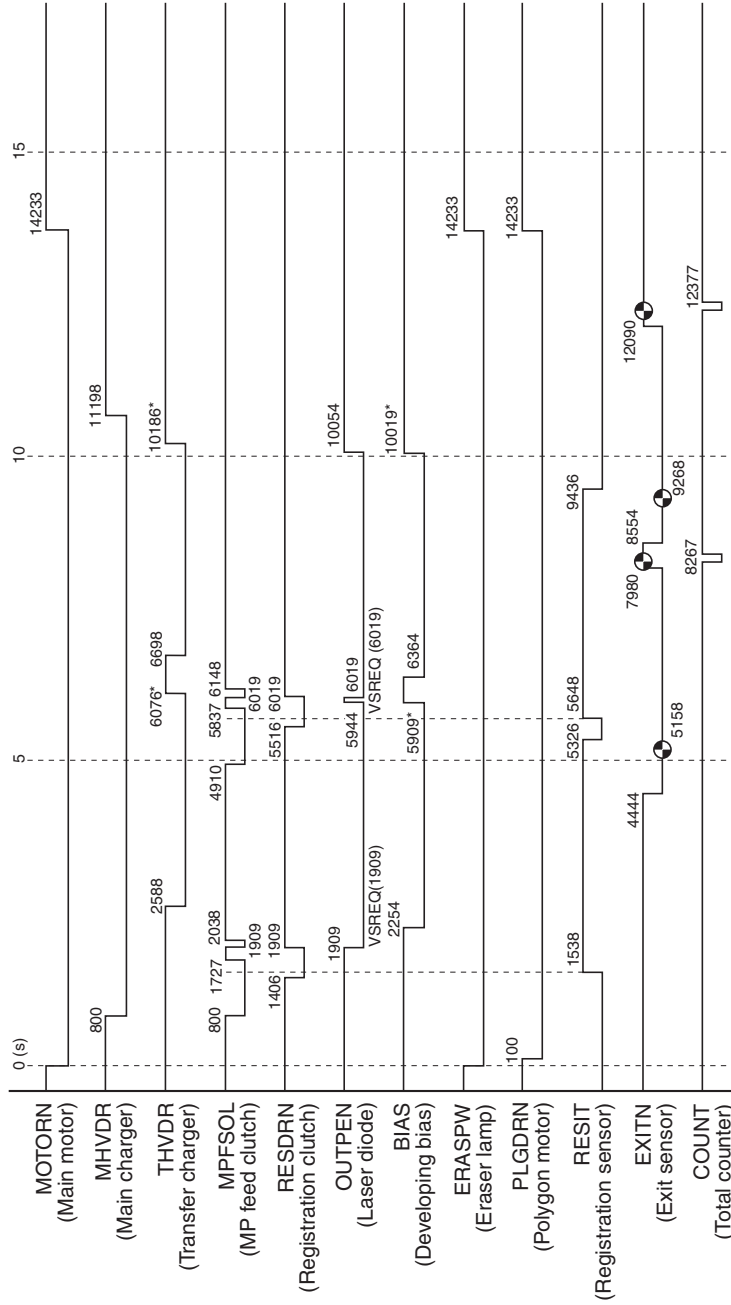

\*: Varies depending on paper size.

Drum speed: 84.00 mm/s

Paper feeding speed: 84.00 mm/s

Printing speed: 14.27 ppm

●: Jam detection timing

## 5. MP tray feeding, two legal size papers

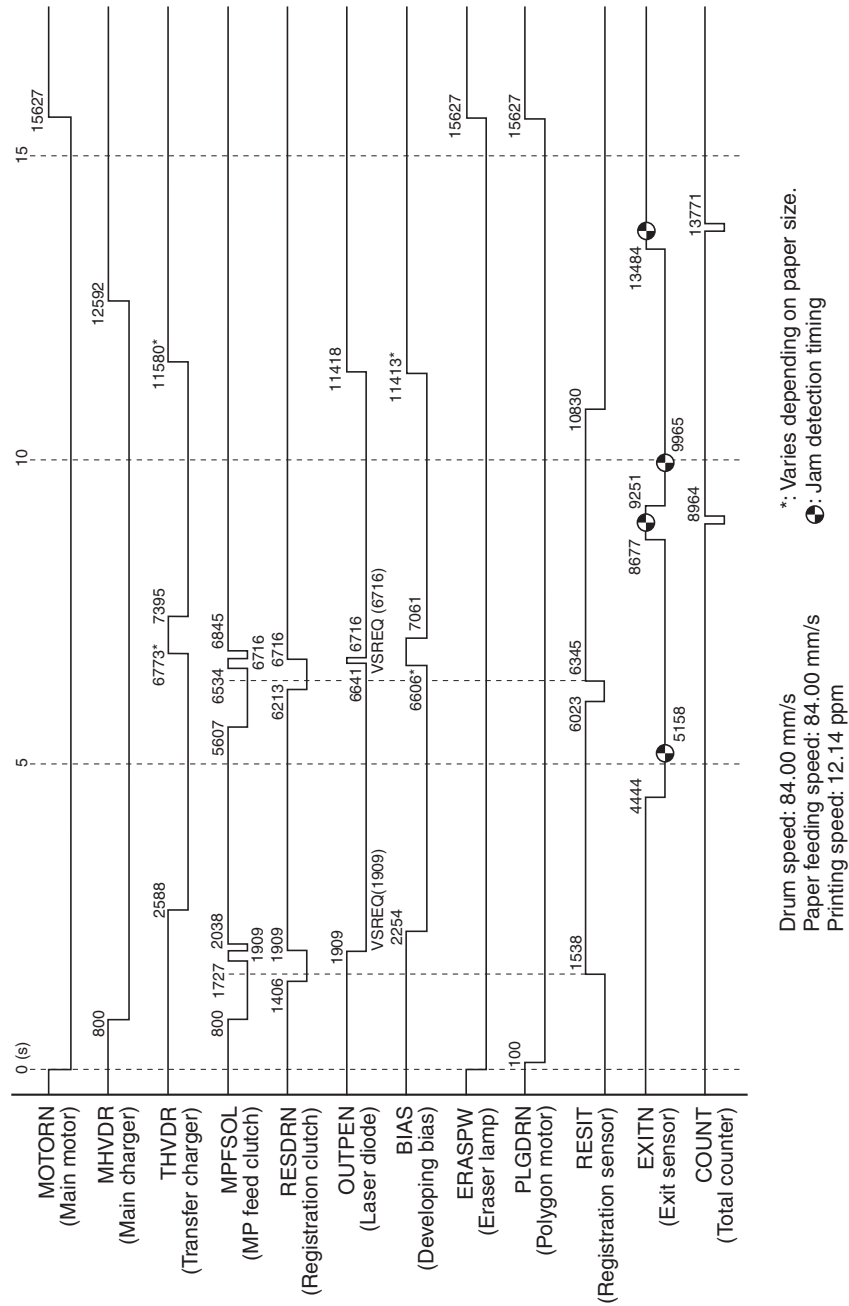

## 6. MP tray feeding, two letter size papers

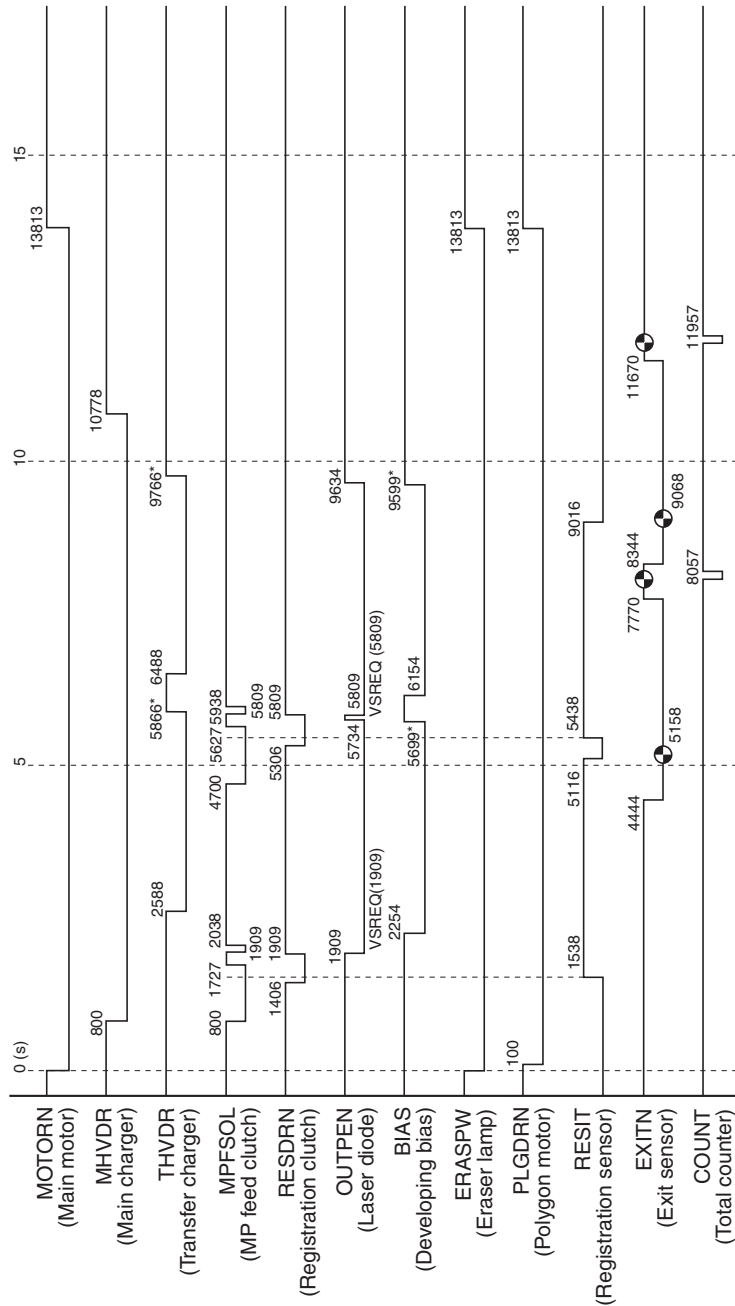

\*: Varies depending on paper size.

Drum speed: 84.00 mm/s  
 Paper feeding speed: 84.00 mm/s  
 Printing speed: 14.75 ppm

●: Jam detection timing



**Appendix B**    **S t a t u s**    **P a g e**

# Appendix B Contents

**Status page** ..... **B-3**  
    Printing the service status page ..... B-3  
    Details of service information ..... B-4

# Status page

The printer can print different types of the status page—the user (normal) status page and the service status page. This section exclusively describes information obtainable with the service status page. For information on the user (normal) status page, refer to the printer's *User's Manual*.

Information on the service page include various settings for the printer, service statistics, etc. To print a service status page, proceed as follows:

## Printing the service status page

To print a service status page, using the MENU key. Or, have a PC running MS-DOS and proceed as follows:

1. Connect the printer to the PC via the parallel interface.
2. Ensure that the printer is ready to print.
3. At the DOS prompt, type:

```
echo !R! STAT 1; EXIT; >lpt1:
```

The service status page is printed. (If you omit '1,' a user status page is printed.) Service information on the status page



An example of the service status page is shown below. (Note the details born by the status page may differ from a firmware version to another.) Most of the service information are located under *Service information*.

Most of these service information on the status page are alphanumerically-coded. Each item is explained on the next page.

### Details of service information

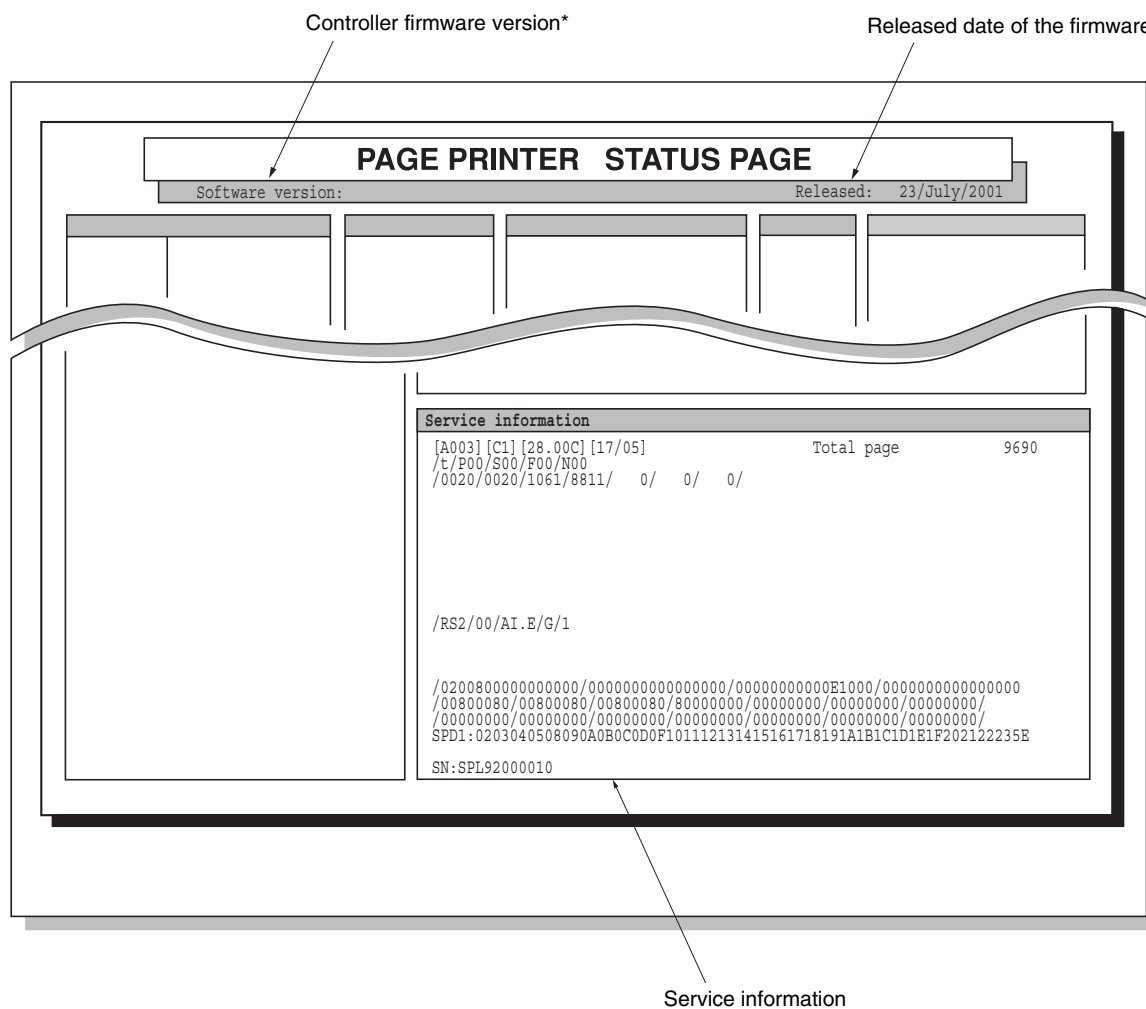

Service information	
[A003] [C1] [28.00C] [17/05]	Total page 9690
① ② ③ ④	⑤
/t/P00/S00/F00/N00	
⑥ ⑦ ⑧ ⑨ ⑩	
/0020/0020/1061/8811/ 0/ 0/ 0/	
⑪ ⑫ ⑬ ⑭ ⑮	
/RS2/00/AI.E/G/1	
⑯ ⑰ ⑱ ⑲ ⑳	
/0200800000000000/0000000000000000/00000000000E1000/0000000000000000	㉑
/008000080/008000080/008000080/80000000/00000000/00000000/00000000/	㉒
/00000000/00000000/00000000/00000000/00000000/00000000/00000000/	㉓
SPD1:0203040508090A0B0C0D0F101112131415161718191A1B1C1D1E1F202122235E	㉔
SN:SPL92000010	㉕

Example	Meaning	Description
① [A003]	Engine ROM version	-
② [C1]	Operator panel mask ROM version	-
③ [28.00C]	Boot ROM version	-
④ [17/05]	Internal use	-
⑤ Total page 9690	Total count page	-
⑥ /t	Internal use	-

Example	Meaning	Description
⑦ P00/	Parallel interface mode	bit 7= 0: No error with bidirectional communication, 1: Error with bidirectional communication bit 6= 0: No ECP communication, 1: ECP communication had occurred, at least once. bit 0 to 5= History of printer parallel port directional communication. 05= Nibble (High-speed), 07= ECP
⑧ S00/	Serial interface error	00= Normal, bit 0= Framing error bit 1= Overrun, bit 2= Parity error
⑨ F00/	Operator panel lock (Shown only during locking)	01= Partially locked 02= Fully locked
⑩ N00/	NVRAM error (Shown only if error has occurred)	01= ID error, 02= Version error, 03= Checksum error, 04= NVRAM error
⑪ /0020	Top margin	Inches+ <sup>1</sup> / <sub>100</sub> inches (FRPO L1/L2)
⑫ /0020	Left margin	Inches+ <sup>1</sup> / <sub>100</sub> inches (FRPO L2/L3)
⑬ /1061	Page length	Inches+ <sup>1</sup> / <sub>100</sub> inches (FRPO L4/L5)
⑭ /0811	Page width	Inches+ <sup>1</sup> / <sub>100</sub> inches (FRPO L6/L7)
⑮ / 0/ 0/ 0/	Left margin offset for paper source (MP tray/Printer's cassette/Optional paper feeder's cassette)	In + <sup>1</sup> / <sub>600</sub> inch
⑯ RS2	Serial interface mode (Shown only optional serial interface board is installed) Average print coverage (total)	RS2= RS-232C, RS4= RS422A
⑰ /00	Calibration table setting	Hexadecimal (FRPO I4)

Example	Meaning	Description
⑱ /AI.E	Average print coverage (sum total)	Two digits for integer part; one digit for decimal; unit is in percent
⑲ /G	Average print coverage (most recent 20 pages)	B= Level 1 (Less than 0.5 %) C= Level 2 (0.6 to 1.0 %) D= Level 3 (1.1 to 2.0 %) E= Level 4 (2.1 to 3.0 %) F= Level 5 (3.1 to 4.0 %) G= Level 6 (4.1 to 5.0 %) H= Level 7 (5.1 to 10.0 %) I= Level 8 (More than 10.0 %)
⑳ /1	Operator panel message language	PMSG command setting (decimal)
㉑ /020080000000...	Engine parameter setting	Hexadecimal, 32 bytes (64 digits)
㉒ /00800080/...	Media type attribute setting	Media type 1 to 28 (Reserved: 12 to 20) Fuser temperature, paper weight, and duplex print setting value
㉓ /00000000/...	Media type attribute setting	Media type 1 to 28 (Reserved: 12 to 20) For print density setting value
㉔ SPD1:02030405...	DRAM SPD (slot 1)	-
㉕ SN:SPL9200010	Serial number for the printer	-

## **Appendix C   I n t e r f a c e**

## Appendix C Contents

<b>Parallel interface</b> .....	<b>C-3</b>
Selecting the parallel interface mode .....	C-3
Parallel interface pin assignment .....	C-4
Parallel interface signals .....	C-5
<b>USB interface</b> .....	<b>C-6</b>
USB interface pin assignment .....	C-6
<b>Serial interface (Optional)</b> .....	<b>C-7</b>
Changing the serial interface configuration .....	C-7
Serial interface signals .....	C-9
RS-232C interface voltage levels .....	C-9
RS-422A interface voltage levels .....	C-9
Connector configurations .....	C-10
RS-232C - For computers with a DB-9 connector .....	C-10
RS-232C - For computers with a DB-25 connector .....	C-10
RS-422A .....	C-11
Protocol .....	C-11

# Parallel interface

The printer uses a bidirectional parallel interface for high-speed data transmission for the host computer. This interface includes the buffers which are compatible with the IEEE 1284 standards. The parallel interface provides support for the ECP and nibble modes in this standards. The parallel interface mode can be changed by commanding Prescribe commands on a PC.

## Selecting the parallel interface mode

To change the parallel interface mode, use the menu selection from the operator panel as the following steps:

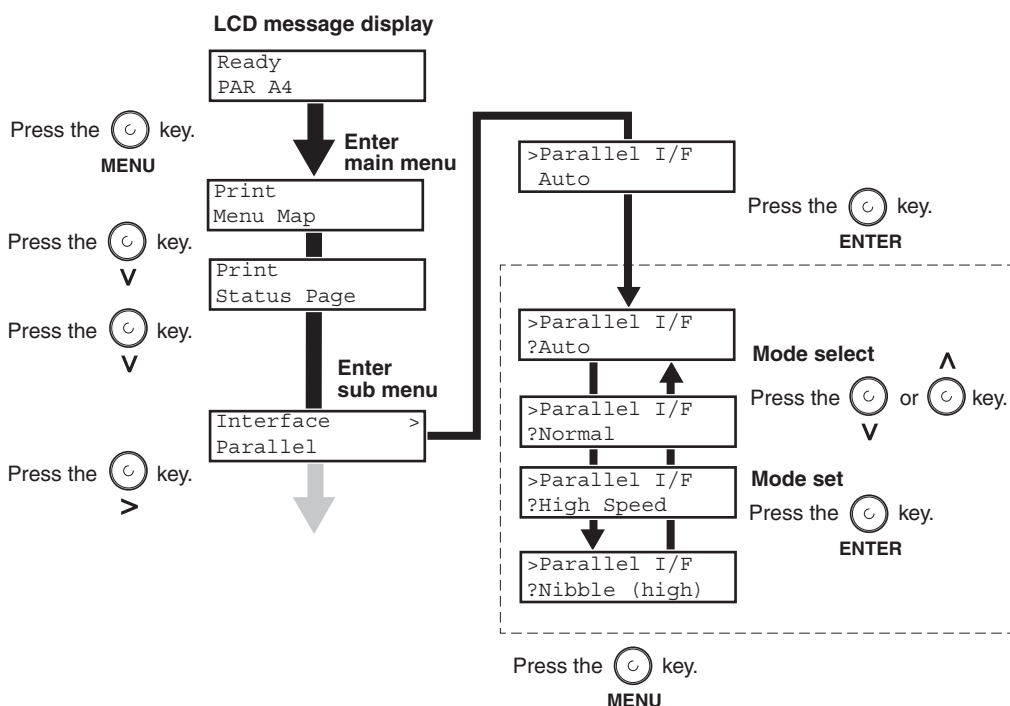

The parallel interface mode is also change with a method from the running MS-DOS PC. Connect the printer to the PC via the parallel interface. Then, at the DOS prompt, type a FRPO 00 (the letter O and the number zero) command as follows depending on the desired parallel mode:

To set the parallel interface mode...	Type at the DOS prompt...
Normal	<code>echo !R! FPRO 00, 0; EXIT; lpt1:</code>
High-speed	<code>echo !R! FPRO 00, 1; EXIT; lpt1:</code>
Nibble	<code>echo !R! FPRO 00, 5; EXIT; lpt1:</code>
Automatic*	<code>echo !R! FPRO 00, 70; EXIT; lpt1:</code>

\*: Factory-set default.

## Parallel interface pin assignment

The pins of the parallel interface connector carry the signals listed below. The function for each signal is detailed on the following page.

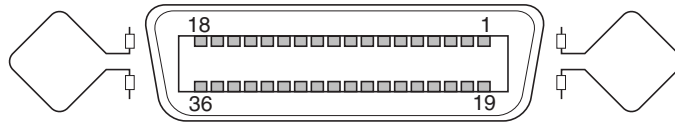

No.	Terminal	Signal	No.	Terminal	Signal
1	nStrobe	(STBIN1/2*)	19	Ground	GND
2	Data1	(PAD0)	20	Ground	GND
3	Data2	(PAD1)	21	Ground	GND
4	Data3	(PAD2)	22	Ground	GND
5	Data4	(PAD3)	23	Ground	GND
6	Data5	(PAD4)	24	Ground	GND
7	Data6	(PAD5)	25	Ground	GND
8	Data7	(PAD6)	26	Ground	GND
9	Data8	(PAD7)	27	Ground	GND
10	nAck	(ACKOUT)	28	Ground	GND
11	Busy	(BUSYOUT)	29	Ground	GND
12	PError	(PERROR)	30	Ground	GND
13	Select	(SELECT)	31	nInit	(INIT*)
14	nAutoFd	(AUTOFD*)	32	nFault	(FAULT*)
15	Not defined	NC	33	Not defined	Pull-up (1k $\Omega$ )
16	Logic ground	GND	34	Not defined	NC
17	Chassis ground	GND	35	Not defined	Pull-up (1k $\Omega$ )
18	Peri-logic H	(VCC)	36	nSelect In	(SELECTI*)

Maximum rated current for pin 18 is 400 mA (fused).



## Parallel interface signals

The following table provides details for the signals used on the printer's parallel interface. Note descriptions in [ ] are for high-speed mode of the parallel interface.

Signal	Meaning
Strobe* [nStrobe] (Pin 1)	A negative-going Strobe* pulse causes the printer to read and latch the data on the Data 0 [1] to Data 7 [8] signal lines.
Data 0 [1] to Data 7 [8] (Pins 2 to 9)	These eight signals form the data byte sent from the host computer to the printer. Data 7 [8] is the most significant bit and Data 0 [1] is the least significant bit.
Acknowledge* [nAck] (Pin 10)	This signal is returned to the host computer. This negative-going pulse acknowledges the previous character received by the printer. Acknowledge* pulses are sent only when Busy is low.
Busy [Busy] (Pin 11)	This signal is returned to the host computer. This signal is high when the printer is busy and low when it is able to accept more data. Every high-to-low transition is followed by an Acknowledge* pulse.
Paper Empty [PError] (Pin 12)	This signal is returned to the host computer. This signal goes high when the printer runs out of paper.
On-Line [Select] (Pin 13)	This signal is returned to the host computer. This signal is high when the printer is on-line and low when the printer is off-line. It goes low when the upper unit is raised, or when the GO key is pressed to set the printer off-line. <i>Note:</i> The Paper Empty and On-Line signals are not used unless enabled by the FRPO command (O2 parameter).
Auto-Feed [nAutoFd] (Pin 14)	This signal is used in the Epson version of the Centronics interface to receive a carriage return. In high-speed mode, it is used as an interrupt.
+5 V DC (pin 18)	This line is connected to the printer's +5 V DC line (+5 V $\pm$ 0.5 V, 400 mA maximum, fused).
Prime [nInit] (Pin 31)	This signal is used in the standard Centronics interface to enable the computer to reset the printer. It is ignored by the printer.
Error* [nFault] (Pin 32)	When the high-speed parallel line control is on (FRPO O2 = 2), this line returns error status to the host computer.
Auxiliary output 1 (Pin 33)	This signal line is not used.
Power Ready (Pin 35)	This signal is high when the printer's power is on.
Select In [NSelectIn]	This signal is used in some versions of the Centronics interface to enable the computer to force the printer on-line. In high-speed mode, it is used as an interrupt.

## USB interface

This printer supports the USB (Universal Serial Bus) Revision 1.1 standards. USB interface specifications and interface signals are as follows:

Item	Specifications
Basic specification	Complies with the USB Revision 1.1 standards.
Connectors	Printer: B-type receptacle (female) with upstream port Cable: B-type plug (male)
Cable	Use shielded cable that complies with the USB Revision 1.1 standards and not longer than 5 meters (16 feet).
Transfer mode	Full speed (max. 12 Mbps)
Power control	Self-power device

### USB interface pin assignment

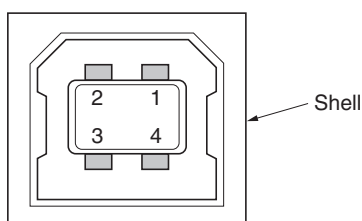

No.	Signal	Description
1	Vbus	Power supply (+5 V)
2	D-	Data transmission
3	D+	Data transmission
4	GND	Signal ground Shell Shield

Shell: Shield

## Serial interface (Optional)

The printer is equipped with an optional slot for adding a serial port. To add a serial port, the serial interface board is equipped.

The device responsible for controlling the serial interface is integrated in the gate array in the controller system. The serial interface supports both protocols of RS-232C and RS-422A.

Toggling the protocol between RS-232C and RS-422A is made by a shorting jumper socket that is accessible on the main board. (The jumper wire arrangement, that used to be provided for the succeeding models to switch the DTR polarity is not used with these models.) To change the serial interface protocol, refer to *Changing the serial interface configuration* section which follows.

A 25-pin D-sub connector is used for the serial interface. The extra signals used for RS-422A are assigned to these pins that are not used for RS-232C according to the IBM pin assignment scheme.

### Changing the serial interface configuration

To change the serial interface protocol from RS-232C to RS-422A, or vice versa, the IB-10E board must be taken out from the printer. Protect the electronics by taking these precautions:

#### CAUTION



Before touching the main board, touch a water pipe or other large metal object to discharge yourself of static electricity. While doing the work, it is recommended that you wear an antistatic wrist strap.

Touch the main board only by the edge.

Remove two thumb screws ① then draw the serial interface board ②. To change the serial protocol from RS-232C to RS-422A, for example, carefully remove the jumper connector ③ on the serial interface board ②. Reconnect to the pin position as shown in the diagram. Replace the serial interface board ② back into the printer. Secure the board by the thumb screws.

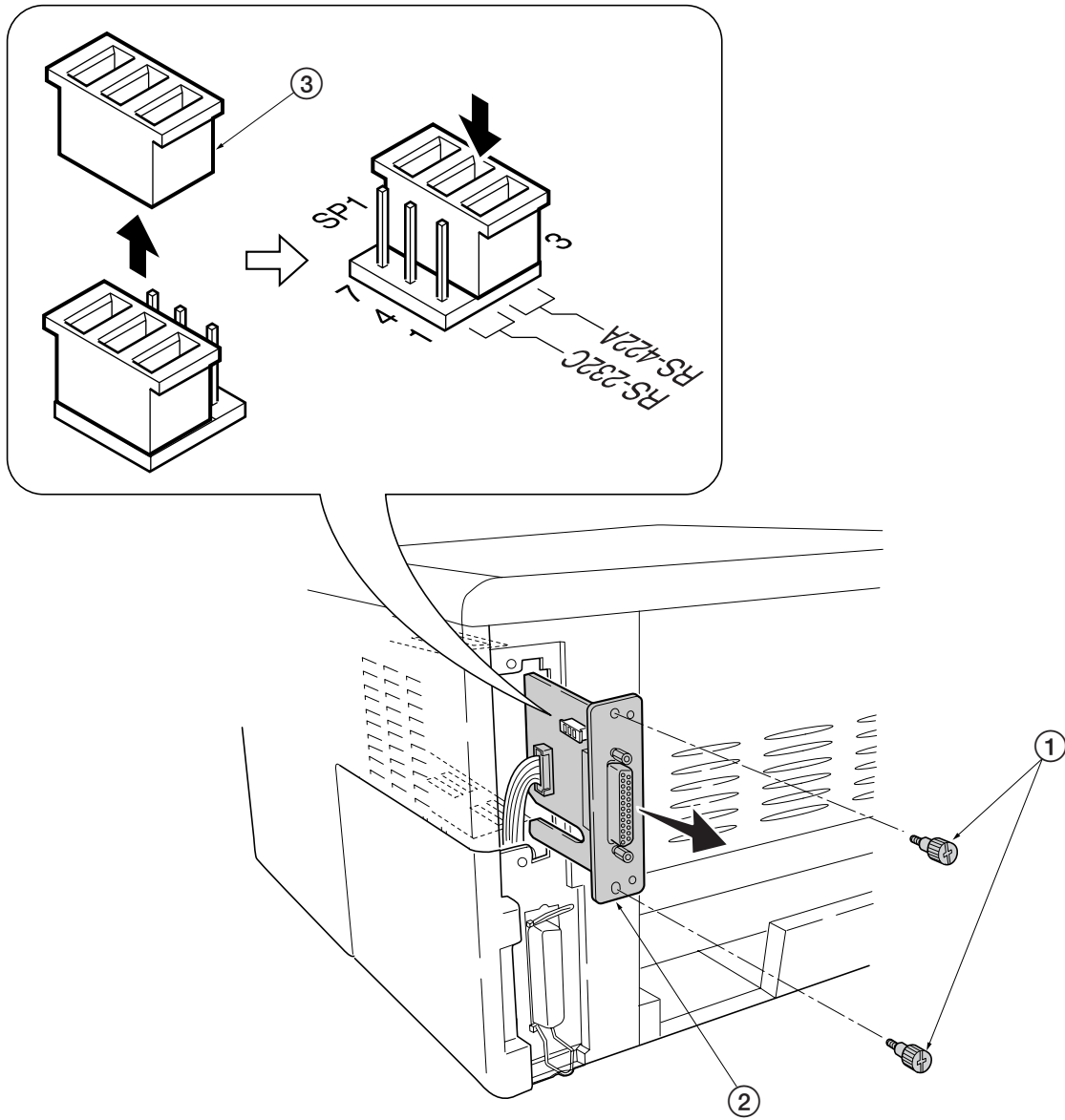

## Serial interface signals

The following table provides details for the signals used on the serial interface board.

Signal	Meaning
FG (Pin 1)	This pin is connected directly to the printer frame.
TxD (Pin 2)	RS-232C only: This output carries asynchronous data sent by the printer to the computer. It is used mainly in handshaking protocols.
RxD/RDA (Pin 3)	This input carries serial asynchronous data sent by the computer to the printer. In RS-422A, this carries the inverted differential data (RDA).
RTS (Pin 4)	This output is always held high (above 3 V).
CTS (Pin 5)	Unused.
DSR (Pin 6)	Unused.
SG (Pin 7)	All signals can transmit between the printer and the host computer to send each signals with a signal ground.
SDA (Pin 8, 9)	This output transmits asynchronous inverted form of differential data from the printer to the computer.
SDB (Pin 8, 10)	This output carries asynchronous non-inverted form of differential data from the computer to the printer.
DTR (Pin 20)	This output is used as a buffer nearly-full handshake line. It is held high (above 3 V) when the buffer can accept more data.

### RS-232C interface voltage levels

The voltage levels of the RS-232C signals conform to EIA RS-232C specifications. FALSE is from 3 volts to 15 volts. TRUE is from -3 volts to -15 volts. Voltages between -3 volts and 3 volts are undefined. The voltage levels of the RS-422A signals are equivalent to those of the RS-232C signals except the signals used for transmission and reception.

### RS-422A interface voltage levels

The interface signal voltage levels for RS-422A conforms with the EIA RS-422A standards. The differential voltage ranges is from 200 mV to 6 V.

## Connector configurations

The printer uses a DB-25 connector for the serial interface. Depending on the computer configurations for serial interface, use either of the appropriate configurations. A special cable must be prepared or obtained for the RS-422A configuration by referring to the diagram (last) below.

### RS-232C - For computers with a DB-9 connector

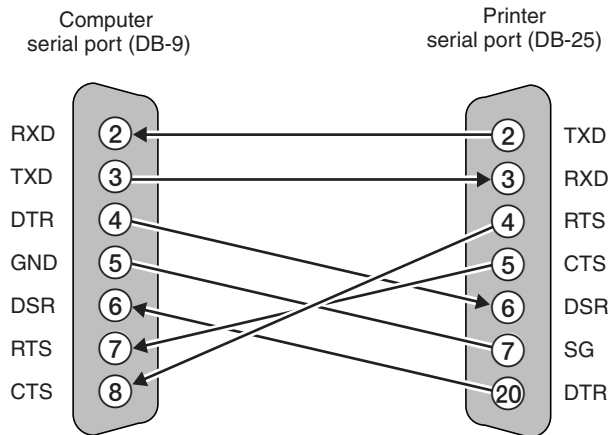

### RS-232C - For computers with a DB-25 connector

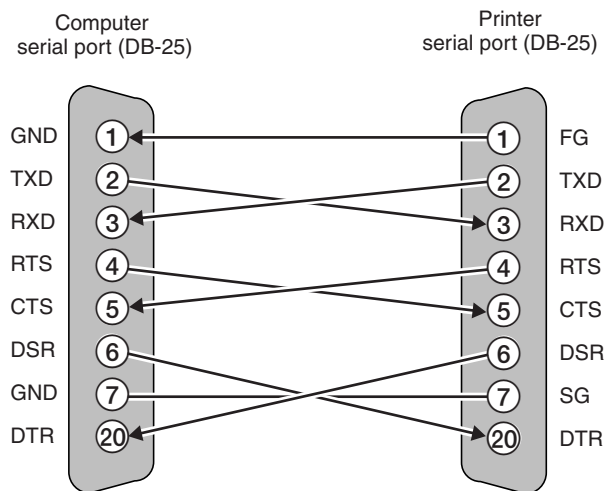

## RS-422A

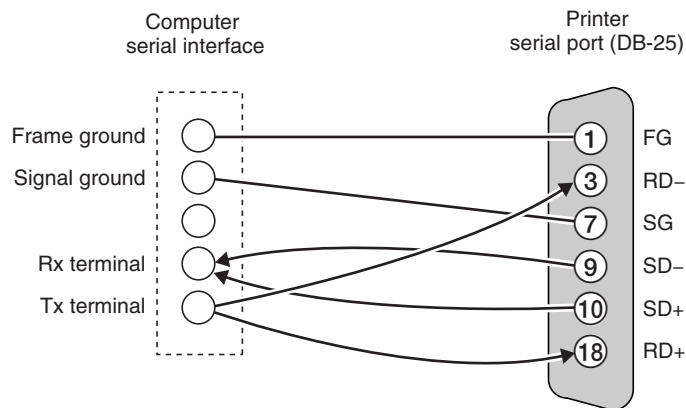

On the computer serial port, investigate pin assignments depends on the computer manufacture's instruction. Since the RS-422A configuration does not employ control lines except for data transmission/reception, select a mode in which signals such as DTR are not used.

### Protocol

The serial interface supports the full baud rate of: 1200, 2400, 4800, 9600, and 19200, 38400, 57600 and 115.2 k (bps). For adjusting serial interface parameters including baud rate, parity, etc., refer to optional *Serial interface board User's Manual*.

**KYOCERA MITA EUROPE B.V.**

Hoeksteen 40, 2132 MS Hoofddorp,  
The Netherlands  
Phone: (020) 6540000  
Home page: <http://www.kyoceramita-europe.com>  
Email: [info@kyoceramita-europe.com](mailto:info@kyoceramita-europe.com)

**KYOCERA MITA NEDERLAND B.V.**

Hoeksteen 40, 2132 MS Hoofddorp,  
The Netherlands  
Phone: (020) 5877200

**KYOCERA MITA (UK) LIMITED**

8 Beacontree Plaza  
Gillette Way,  
Reading RG2 0BS UK  
Phone: (0118) 931 1500

**KYOCERA MITA ITALIA S.P.A.**

Via Verdi 89/91 20063 Cernusco sul Naviglio  
(Milano) Italy  
Phone: 02-92179 1

**S.A. KYOCERA MITA BELGIUM N.V.**

Hermesstraat 8A, 1930 Zaventem, Belgium  
Phone: (02) 7209270

**KYOCERA MITA FRANCE S.A.**

Parc les Algorithmes  
SAINT AUBIN  
91194 GIF-SUR-YVETTE  
France  
Phone: (01) 69852600

**KYOCERA MITA ESPAÑA S.A.**

Edificio Mita, Avda. De Manacor Nº2,  
Urb. Parque Rozas, Apartado de Correos 76,  
28230 Las Rozas, Madrid, Spain  
Phone: (91) 631-8392

**KYOCERA MITA FINLAND OY**

Kirvesmiehenkatu 4, 00810 Helsinki,  
Finland  
Phone: (09) 478-05200

**KYOCERA MITA (SCHWEIZ) AG**

Hölzliwisen, Industriestrasse 28,  
8604 Volketswil, Switzerland  
Phone: (01) 908 4949

**KYOCERA MITA DEUTSCHLAND GMBH**

Mollsfeld 12 40670 Meerbusch,  
Germany  
Phone: 02159-918120

**KYOCERA MITA GMBH AUSTRIA**

Eduard-Kittenberger-Gasse 95,  
1230, Wien, Austria  
Phone: (01) 86338-0

**KYOCERA MITA SVENSKA AB**

Siktgatan 2,  
162 50 Vällingby, Sweden  
Phone: (08) 4719999

**KYOCERA MITA DANMARK A/S**

Industrivej 11, DK-4632 Bjæverskov,  
Denmark  
Phone: 56871100

**KYOCERA MITA PORTUGAL LDA.**

CASCAISTOCK-Armazem nº8,  
Rua das Fiskas, Alcoitão,  
2765 Estoril, Portugal  
Phone: (21) 4602221

**KYOCERA MITA SOUTH AFRICA  
(PTY) LTD.**

UNIT 3, "Kyalami Crescent,"  
Kyalami Business Park,  
1685 Midrand, South Africa  
Phone: (11) 466-3290

**KYOCERA MITA  
AMERICA, INC.****Headquarters:**

225 Sand Road, P.O. Box 40008,  
Fairfield, New Jersey 07004-0008,  
U.S.A.  
Phone: (973) 808-8444

**KYOCERA MITA AUSTRALIA PTY.  
LTD.**

Level 3, 6-10 Talavera Road, North Ryde,  
N.S.W. 2113 Australia  
Phone: (02) 9888-9999

**KYOCERA MITA NEW ZEALAND LTD.**

1-3 Parkhead Place,  
Albany, Auckland,  
New Zealand  
Phone: (09) 415-4517

**KYOCERA MITA (THAILAND) CORP.,  
LTD.**

9/209 Ratchada-Prachachem Road,  
Bang Sue, Bangkok 10800, Thailand  
Phone: (02) 586-0320

**KYOCERA MITA SINGAPORE  
PTE LTD.**

121 Genting Lane, 3rd Level,  
Singapore 349572  
Phone: (65) 7418733

**KYOCERA MITA HONG KONG  
LIMITED**

11/F., Mita Centre,  
552-566, Castle Peak Road,  
Tsuen Wan, New Territories,  
Hong Kong  
Phone: (852) 24297422

**KYOCERA MITA  
CORPORATION**

2-28, 1-chome, Tamatsukuri, Chuo-ku  
Osaka 540-8585, Japan  
Phone: (06) 6764-3555



## **KYOCERA MITA AMERICA, INC.**

### **Headquarters:**

225 Sand Road, P.O. Box 40008  
Fairfield, New Jersey 07004-0008  
TEL : (973) 808-8444  
FAX : (973) 882-6000

### **New York Show Room:**

149 West 51st street,  
New York, NY 10019  
TEL : (212) 554-2679  
FAX : (212) 554-2625

### **Northeastern Region:**

225 Sand Road, P.O. Box 40008  
Fairfield, New Jersey 07004-0008  
TEL : (973) 808-8444  
FAX : (973) 882-4401

### **Midwestern Region:**

201 Hansen Court Suite 119  
Wood Dale, Illinois 60179  
TEL : (630) 238-9982  
FAX : (630) 238-9487

### **Western Region:**

14101 Alton Parkway,  
Irvine, California 92618-7006  
TEL : (949) 457-9000  
FAX : (949) 457-9119

### **Southeastern Region:**

1500 Oakbrook Drive,  
Norcross, Georgia 30093  
TEL : (770) 729-9786  
FAX : (770) 729-9873

### **Southwestern Region:**

2825 West Story Road,  
Irving, Texas 75038-5299  
TEL : (972) 550-8987  
FAX : (972) 570-4704

### **Dallas Parts Distribution Center & National Training Center:**

2825 West Story Road,  
Irving, Texas 75038-5299  
TEL : (972) 659-0055  
FAX : (972) 570-5816

## **KYOCERA MITA CANADA, LTD.**

6120 Kestrel Road, Mississauga,  
Ontario L5T 1S8, Canada  
TEL : (905) 670-4425  
FAX : (905) 670-8116

## **KYOCERA MITA MEXICO, S.A. DE C.V.**

Av. 16 de Septiembre #407  
Col. Santa Inés,  
02130 Azcapotzalco  
México, D.F. Mexico  
TEL : (5) 383-2741  
FAX : (5) 383-7804

©2001 KYOCERA MITA CORPORATION

 **KYOCERA** is a trademark of Kyocera Corporation

**mita** is a registered trademark of KYOCERA MITA CORPORATION